

Customer Notification

B-CN-084-EN Rev B

1/16/2018

SUBJECT: New DC Bus Bar and Capacitor Bank Assembly Kits

Purpose

This bulletin has been updated to reflect newly identified anticipated release dates for our new DC Bus Bar and Capacitor Bank Assembly Kits. Please refer to page three for this information.

The new kits are backwards compatible to all previous compressor models and will provide an increased reliability.

For TT300 and TG230 compressor models, the bus bar component is being modified to prepare for a future release of the TT300 Major Revision G which will be announced later this year. The change to the bus bar component has been designed in such a way to ensure backwards compatibility for the new kits with previous versions of TT300s.

Summary

The new and updated capacitor kits have the same electrical rating which allows for **backwards compatibility with all previous TT/TG model compressors**; however, these new capacitors have a higher temperature rating which can improve service life in high-stress environments.

NOTE: With this change, some capacitors may have a different color sleeve than the capacitors being replaced. It is important to reference the Danfoss Turbocor Compressor part numbers to guarantee the correct part is being applied.

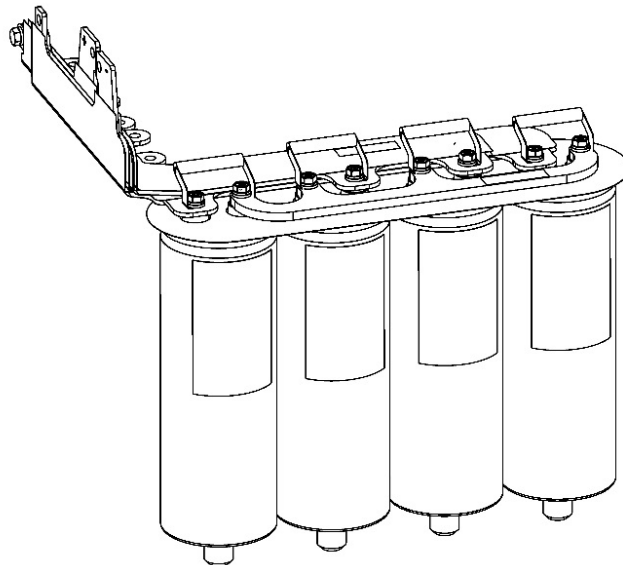

Figure 1 – New Bus Bar and Capacitor Bank Assembly (TT300/TG230 Only)

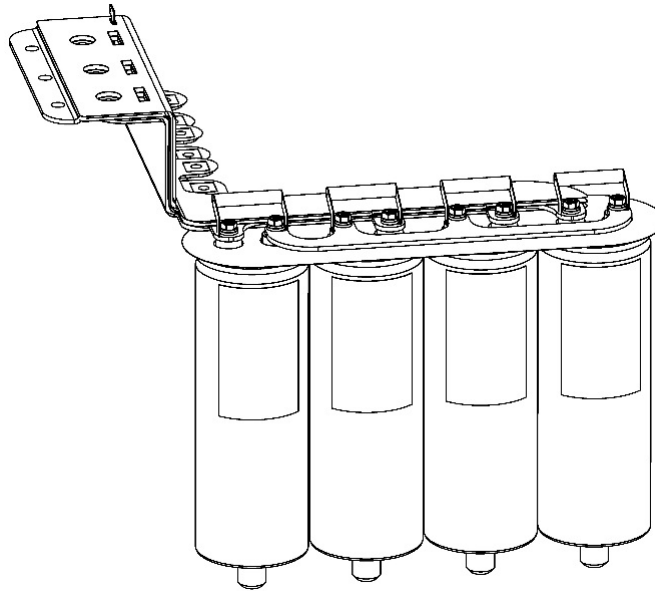

Figure 2 – New Bus Bar and Capacitor Bank Assembly (All TT/TG Compressors Except TT300/TG230)

Action Required

The new Capacitor Bank Assemblies will be rolled out in various phases based on the kit part number. The older kits are going to be made obsolete and will no longer be made available from DTC once the new kits are released.

Consult with your Key Account Manager or our Customer Service Representatives for the exact kit availability at the time of ordering. For orders placed using the old part number, the Customer Service Representative will automatically update the order to the new spare part kit number once it becomes available.

The following tables list the new capacitor kits, their applicability, and the anticipated release dates. The base number of the Capacitor Bank Assembly has not changed (i.e., 100044-) but the suffix part number is now different.

APPLIES TO TT300, TG230

DESCRIPTION	OBSOLETE PART NO.	NEW PART NO.	MAJOR REV	COMMENT	RELEASE DATE
KIT - BUS BAR ASSY AND CAPACITORS 6800 μ F (460V)	100044	100044-7	-N, -P, -C, -D, -E, -F, -G	For use with 460V models, includes nuts	Feb-2018
KIT - BUS BAR ASSY AND CAPACITORS 4700 μ F (575V)	100044-1	100044-8	-N, -P, -C, -D, -E, -F, -G	For use with 575V models, includes nuts	Feb-2018
KIT - BUS BAR ASSY AND CAPACITORS 9000 μ F (380/400V)	100044-2	100044-6	-N, -P, -C, -D, -E, -F, -G	For use with 380/400V models, includes nuts	Feb-2018

APPLIES TO TT350, TT400, TT500, TT700, TG310, TG390, TG520

DESCRIPTION	OBSOLETE PART NO.	NEW PART NO.	MAJOR REV	COMMENT	RELEASE DATE
KIT - BUS BAR ASSY AND CAPACITORS 8500 μ F (460V)	100044-3	100044-12	-P, -A, -C, -E, -F	For use with 460V models, includes nuts	Feb-2018
KIT - BUS BAR ASSY AND CAPACITORS 11000 μ F (380/400V)	100044-4	100044-11	-P, -A, -C, -E, -F	For use with 380V/400V models, includes nuts	Available now

APPLIES TO TT400, TG390

DESCRIPTION	OBSOLETE PART NO.	NEW PART NO.	MAJOR REV	COMMENT	RELEASE DATE
KIT - BUS BAR ASSY AND CAPACITORS 6800 μ F (575V)	100044-5	100044-13	-P, -C, -E, -F	For use with 575V models, includes nuts	Mar-2018

Any OEM, Service Providers, or other Customers who has an existing inventory on hand of the KIT – BUS BAR ASSY AND CAPACITORS which have been made obsolete can continue to use those on the appropriate compressors; however, it is noted that these Kits have a storage life of five (5) years when left idle without charge.

For further questions, please contact product.support@danfoss.com.