

Bulletin | Danfoss Turbocor Compressors

Customer Notification

B-CN-104-EN Rev A

2/5/2018

SUBJECT: Notice of Implementation – TT/TG Series Fastener Change

Purpose

The purpose of this revised bulletin is to provide an update on the release date of the Phase II fasteners. Additionally, this bulletin provides further details regarding the new fasteners (i.e., fastener tool size). This notification will only highlight the changes and does not go into the level of detail that B-CN-080-EN Rev A did.

The release date for the hardware changes is February 10, 2018 at our Tallahassee, Florida production facility. Our production facility in Haiyan, China will begin including the new hardware by March 30, 2018. The changeover in Haiyan could occur sooner if inventory is depleted earlier than currently anticipated.

As previously mentioned, some screws with a Philips head will be changed to either a Torx (T25/T45) or hex head. However, there are no changes to the torque values of the impacted fasteners. Further fasteners are impacted, however, only those impacting the installation of the compressor are identified. Refer to Figure 1 – Impacted Fasteners.

Some of the impacted fasteners are shown below in Figure 1.

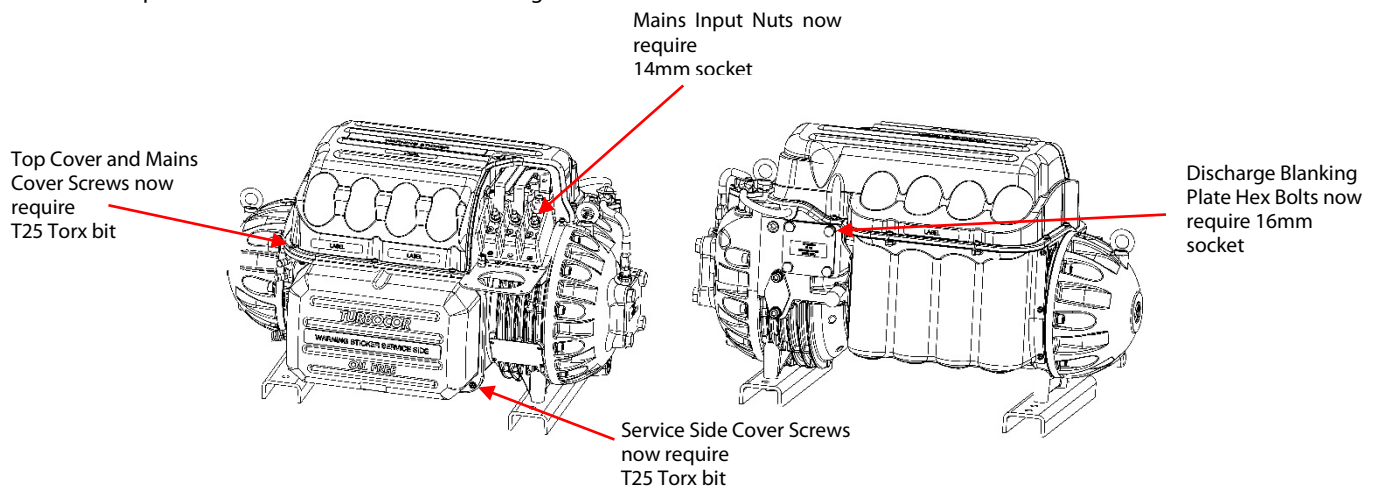

Figure 1 – Impacted Fasteners

Action Required

Customers are not required to take any action as a result of this change in regard to compressor ordering or ordering of spare parts. These changes will be phased into the production of the kits.

Customers however should be aware that there will be a few changes to the size of the tools required to install the compressor. Again, there are no changes to the impacted fastener torque values.

Need Assistance

For further questions, please contact product.support@danfoss.com.