



# KIT INVERTER ASSEMBLY FOR TT300/TG230 MAJOR REVISION "G" AND LATER COMPRESSORS

100043-13



**Installation and servicing of Danfoss Turbocor® compressors by qualified and product trained personnel only. Follow these instructions and sound refrigeration/electrical/servicing practices relating to installation, commissioning, maintenance and service.**

<p>Consult the appropriate Danfoss Turbocor Compressors Inc. (DTC) Service Manual on <a href="http://turbocor.danfoss.com">turbocor.danfoss.com</a> for detailed service instructions.</p>	<p><b>Never power compressor without covers in place and secured.</b></p> <p><b>Removing the mains input cover will expose you to a voltage hazard of up to 575V. Ensure the mains input power is off and locked out before removing cover.</b></p> <p><b>Before removing top cover, wait at least 20 minutes after isolating AC power to allow the high voltage capacitors to discharge.</b></p>	<p>Always wear appropriately rated safety equipment when working around equipment and/or components energized with high voltage.</p> <p><b>This equipment contains hazardous voltages that can cause serious injury or death.</b></p>	<p><b>Recover all refrigerant from compressor in accordance with local codes and ensure pressure is fully vented before the removal of refrigerant containing components.</b></p>
--	---	---	---

1 - Introduction

Inverter Assembly Removal and installation.

2 - Removing Refrigerant from Compressor:

- Recover refrigerant from compressor in accordance with local codes and practices.

3 - INVERTER ASSEMBLY Removal Instructions:

- **NOTE:** Refer to the current Service Manual for more details in removal and installation.

1. Isolate compressor power and lock out in accordance with local codes and practices.
2. Remove the mains cover only.
3. Using an appropriately rated volt meter, confirm that the AC voltage is isolated.
4. Wait at least 20 minutes for the DC bus capacitors to discharge.

**DANGER:** Do NOT touch any components when removing the top cover. This is particularly true for compressors with CE covers because they are coated on the outside for the express purpose of being conductive

5. Remove the top cover by releasing the nine (9) screws that secure the cover, taking particular care not to touch ANY components underneath.
6. Using an appropriately rated volt meter, check the DC bus bars for voltage level. If the voltage is above 5VDC, wait five (5) minutes and recheck until 5VDC or below is achieved.

7. Remove the Soft Start Temperature Harness. Refer to Figure 1 (Soft Start J9 Connector).

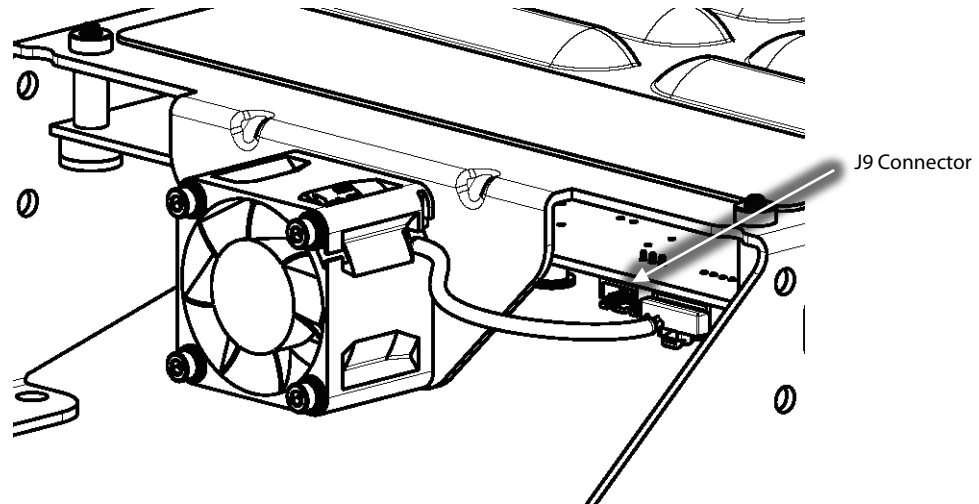

Figure 1 – Soft Start J9 Connector

8. Remove the cable tie securing the Soft Start ground cable to the AC/DC cable.
9. Disconnect the Soft Start ground wire by removing the top nut and mains input ground wire from the ground post on the compressor housing at 3-phase connection point. Refer to Figure 2 (Ground Location).

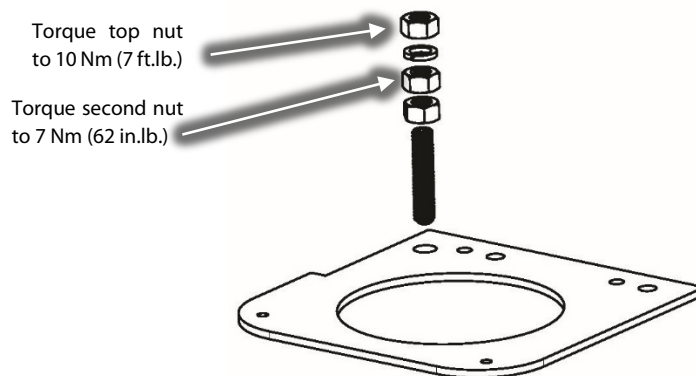

Figure 2 – Ground Location

10. Remove the fasteners that secure the Soft Start mounting bracket to the compressor. Refer to Figure 3 (Soft Start Mounting Screws).

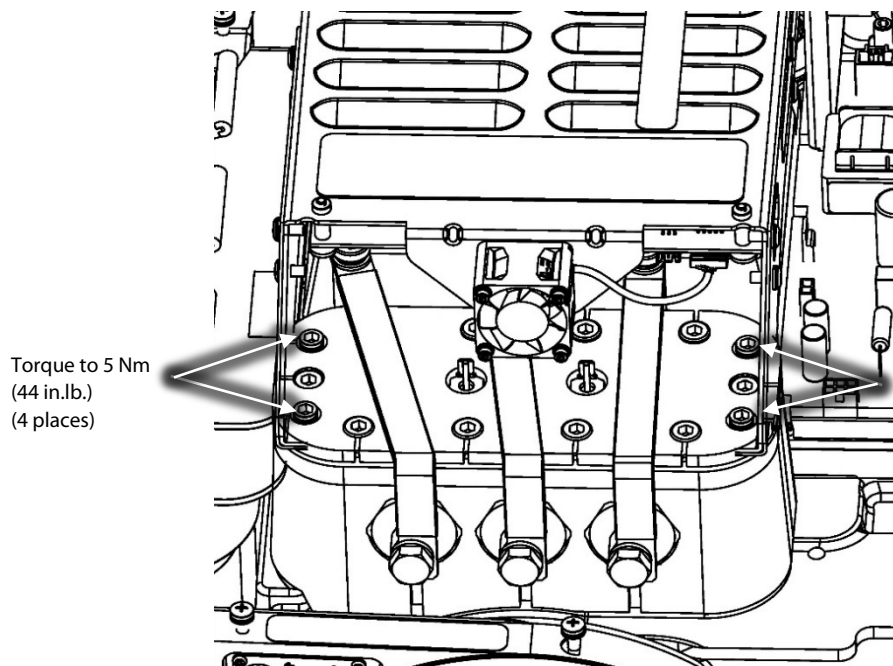

Figure 3 – Soft Start Mounting Screws

11. Lift the Soft Start and turn it over, placing it board-side up on the AC Bus Bars. Refer to Figure 4 (Soft Start Lift).

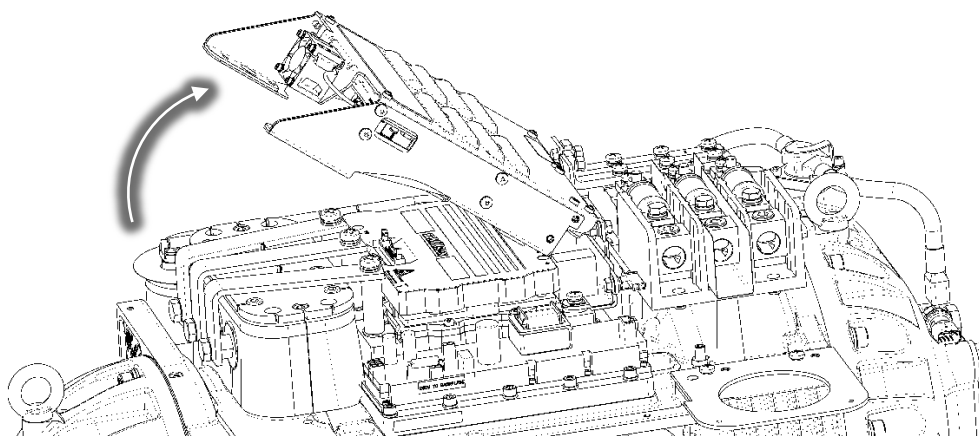

Figure 4 – Soft Start Lift

12. Unplug the cable connectors from the Soft Start board. Refer to Figure 5 (Soft Start Harness Removal).

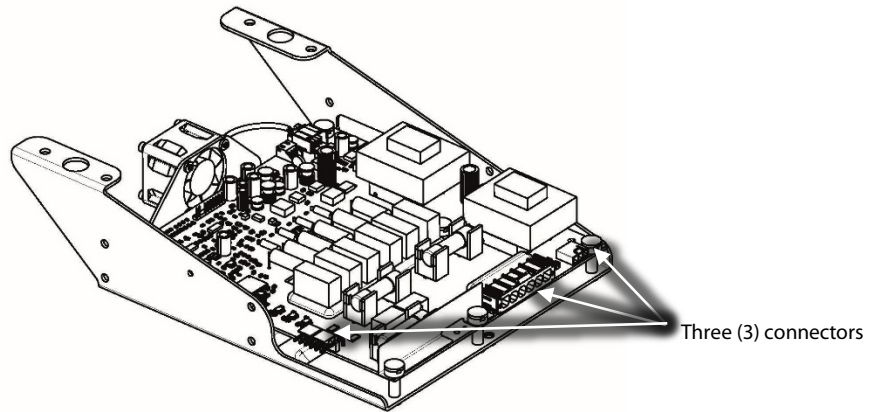

Figure 5 – Soft Start Harness Removal

13. Unplug the Soft Start SCR Gate cable harness from the SCRs noting its orientation. Refer to Figure 6 (Soft Start SCR Gate Cable Harness Removal) for the location of the connectors on the SCRs.

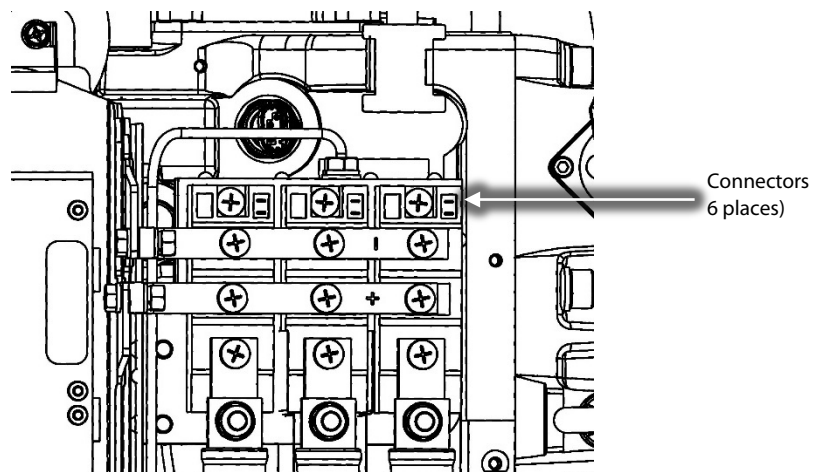

Figure 6 – Soft Start SCR Gate Cable Harness Removal

14. Place the Soft Start board aside.

- Remove the DC Bus Bars from the SCRs. Refer to Figure 7 (DC Bus Bar Removal).

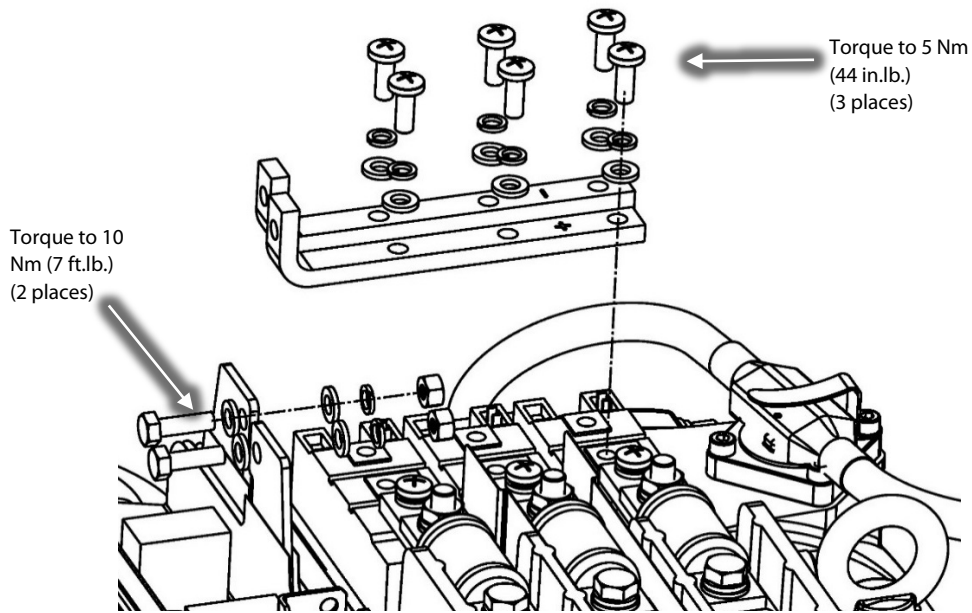

Figure 7 – DC Bus Bar Removal

- Remove the three (3) fasteners that connect the Fast Acting Fuses to the SCR's and, noting their orientation, the 3-Phase input wires to the Soft Start AC/DC cable harness. Refer to Figure 8 (Fuse Block Assemblies).
- Remove the two (2) fasteners from each of the three (3) fuse block assemblies and set aside the fuse assemblies. Refer to Figure 8 (Fuse Block Assemblies) and Figure 9 (Mylar Removal).

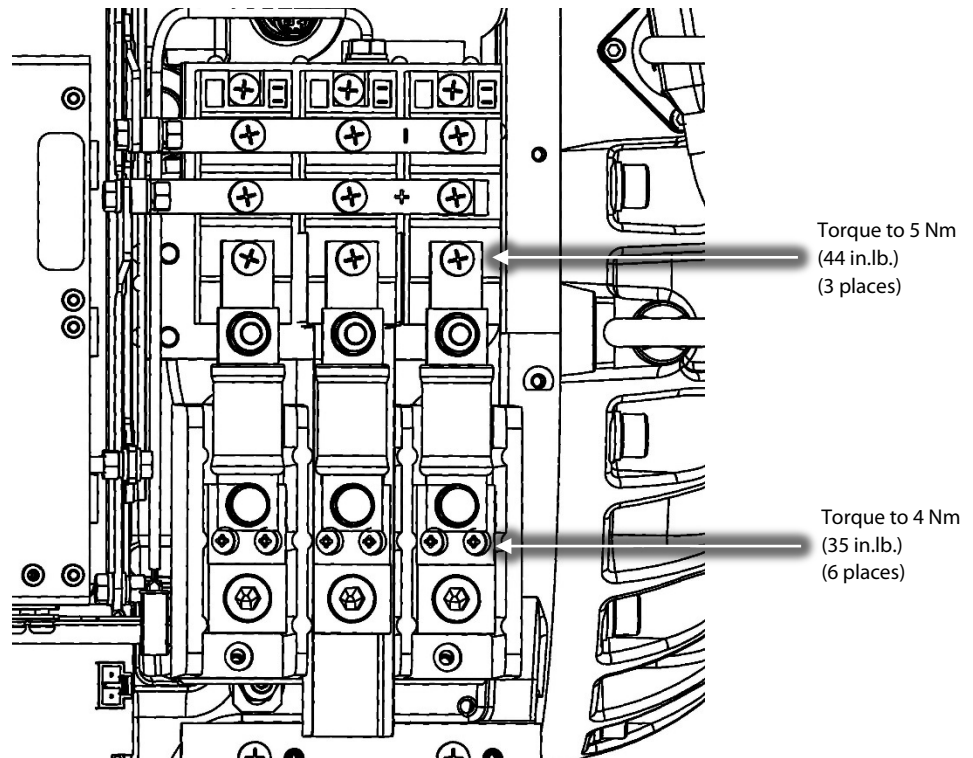

Figure 8 – Fuse Block Assemblies

18. Remove the insulating Mylar from the middle Terminal Block and set aside. Refer to Figure 9 (Mylar Removal).

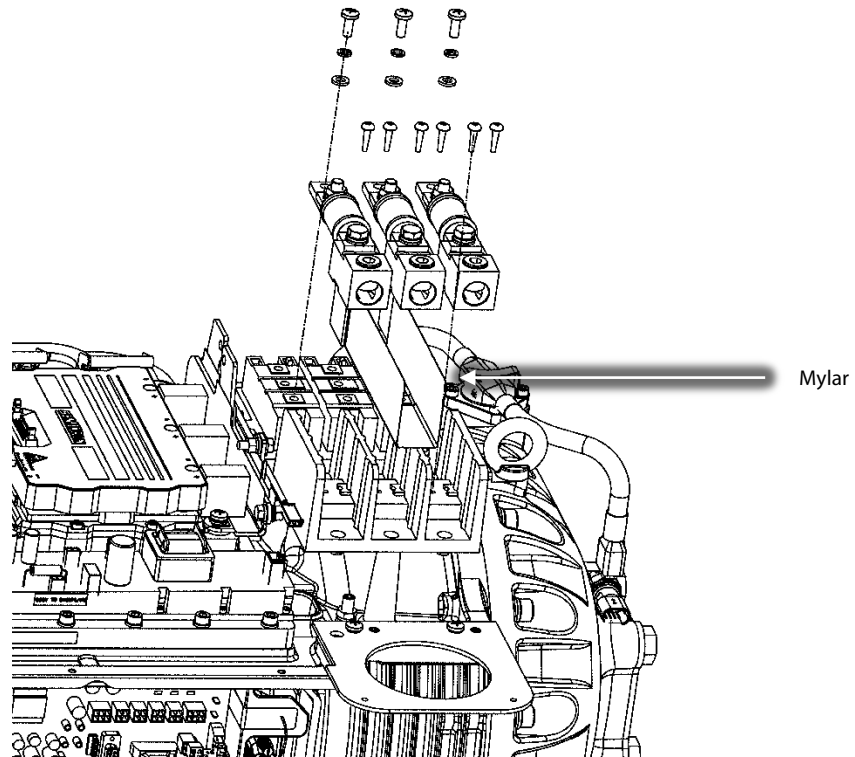

Figure 9 – Mylar Removal

19. Disconnect the DC+ and DC- of the Soft Start harness from the DC bus assembly noting the orientation. Refer to Figure 10 (Soft Start Harness Removal).

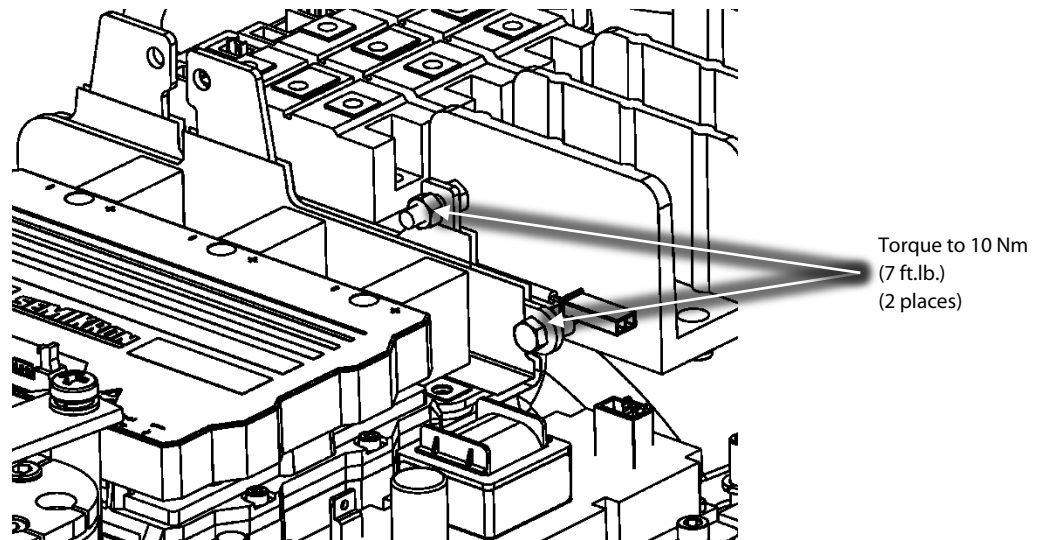

Figure 10 – Soft Start Harness Removal

20. Disconnect the snubber capacitors from the Inverter noting the leg orientation of one leg is longer than the other. Refer to Figure 11 (Snubber Capacitor Removal).

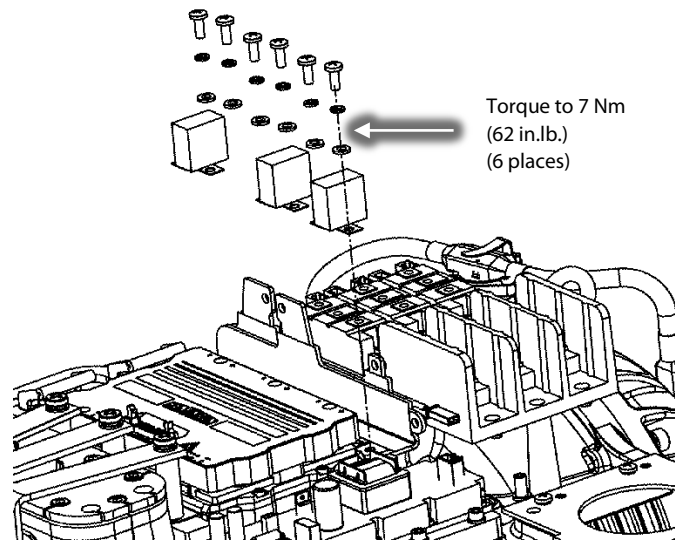

Figure 11 – Snubber Capacitor Removal

21. Remove the nylon nuts at the base of the DC capacitor assembly, under the main compressor housing. Refer to Figure 12 (Capacitor Nut Removal).

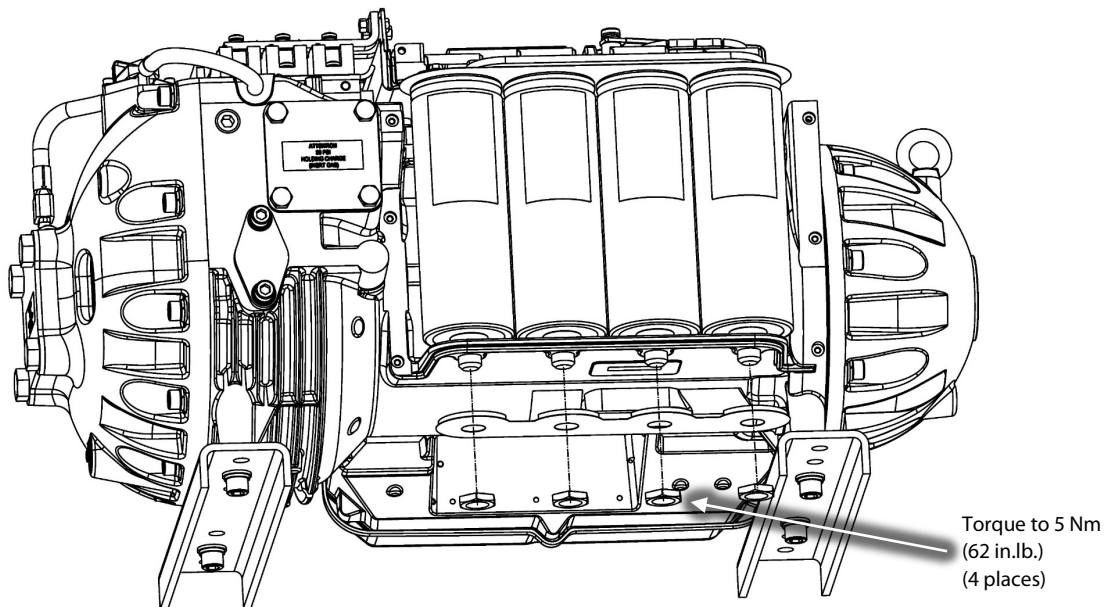

Figure 12 – Capacitor Nut Removal

22. Carefully lift the DC Bus Bars and capacitors out as an assembly. Refer to Figure 13 (Capacitor Assembly Removal).

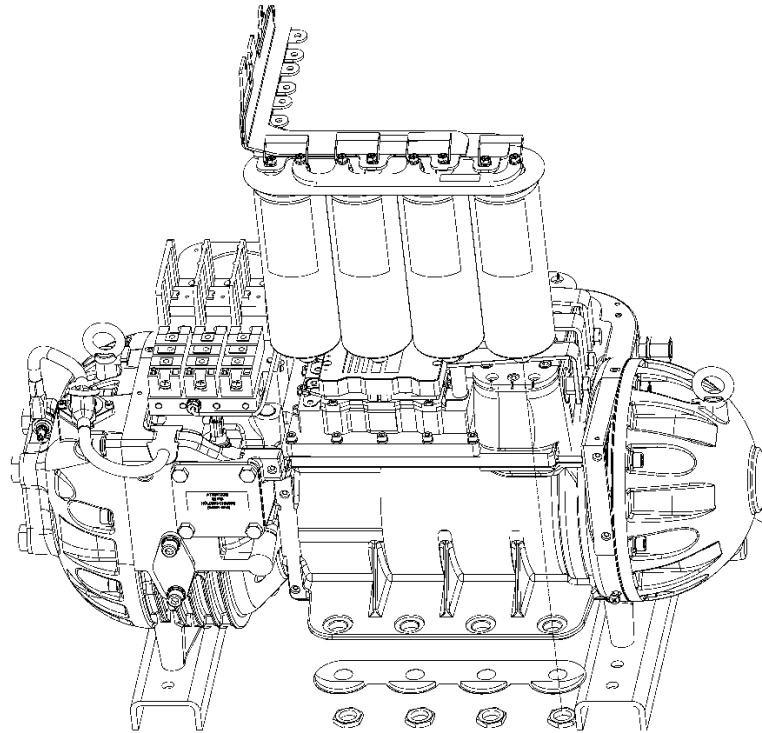

Figure 13 – Capacitor Assembly Removal

23. Remove the Motor Bus Bars from the Inverter and the high-power feed throughs of the motor. Refer to Figure 14 (Motor Bus Bar Removal).

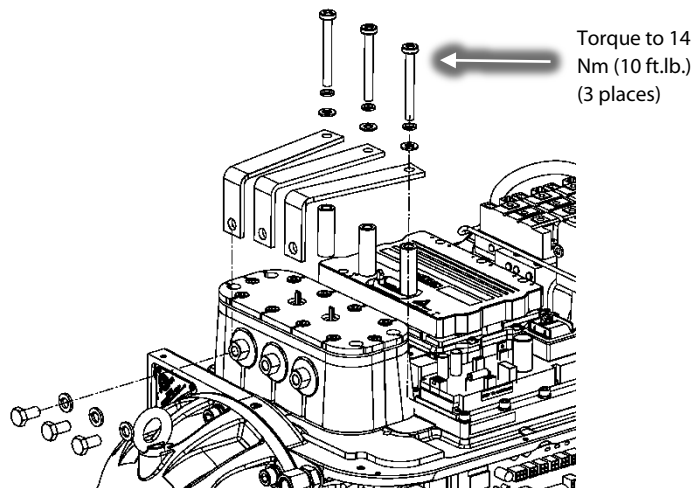

Figure 14 – Motor Bus Bar Removal



24. Remove the Inverter cable harness from the top of the Inverter. Refer to Figure 15 (Inverter Harness Removal).

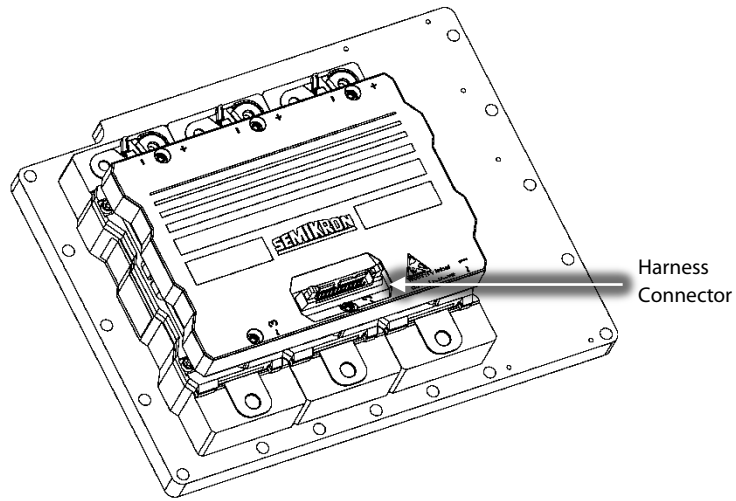

Figure 15 – Inverter Harness Removal

25. Disconnect all wiring connections from the HV DC-DC. Refer to Figure 16 (DC-DC Harness Removal).

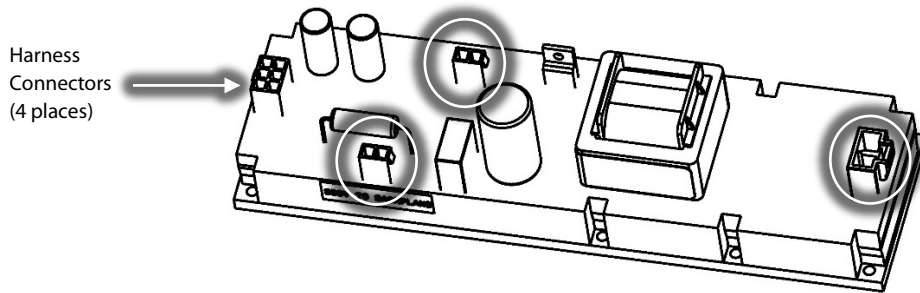

Figure 16 – DC-DC Harness Removal

26. Disconnect the harness from the SCR temperature sensor, discharge P/T sensor, IGV motor connection, and the suction P/T sensor. Set the Compressor Controller Cable Harness aside. Refer to Figure 17 (Cable Harness Compressor Controller Removal).

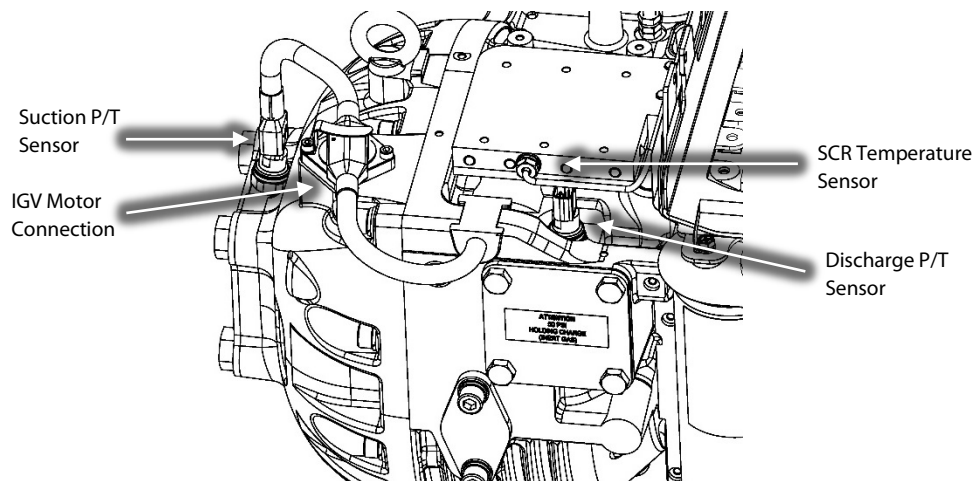

Figure 17 – Cable Harness Compressor Controller Removal

27. Recover refrigerant from compressor in accordance with local codes and practices.
28. Remove the fasteners that secure the Inverter to the compressor main housing. Refer to Figure 18 (Inverter Removal).
29. Carefully, remove the Inverter and discard the two (2) O-rings underneath. (Note that the SCR cooling manifold will be attached to the Inverter cooling plate.)

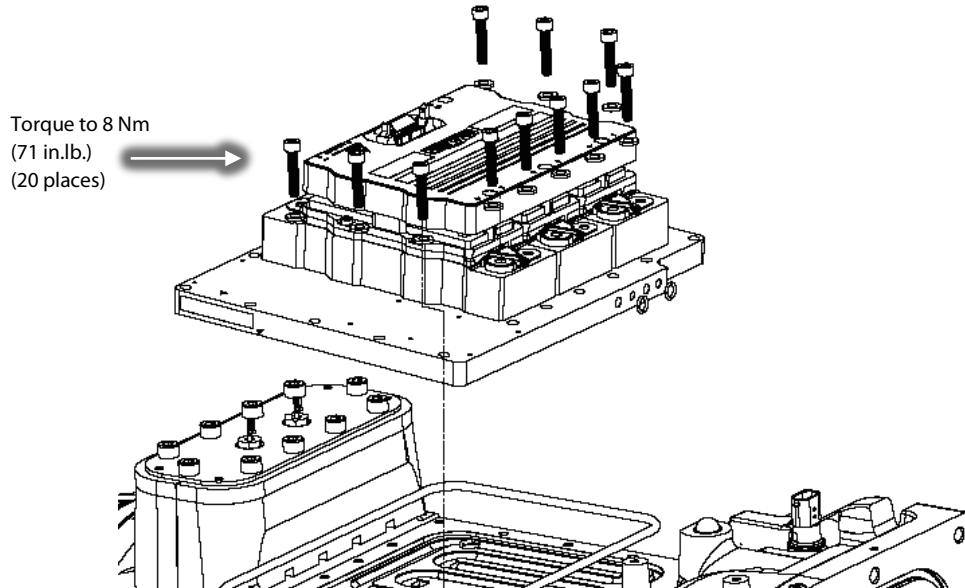

Figure 18 – Inverter Removal

30. Carefully remove the SCR cooling manifold foam insulation in order to gain access to the two (2) screws shown in Figure 19 (SCR Cooling Manifold). Retain for use with the new Inverter assembly.

**NOTE:** Do not completely remove the foam insulation, only pull back what is needed to access the two (2) screws.

31. Remove the two (2) screws indicated in Figure 19 (SCR Cooling Manifold) and carefully remove the SCR Cooling Manifold. Retain for use with the new Inverter assembly.

**NOTE:** The SCRs do not need to be removed from the SCR Cooling Manifold.

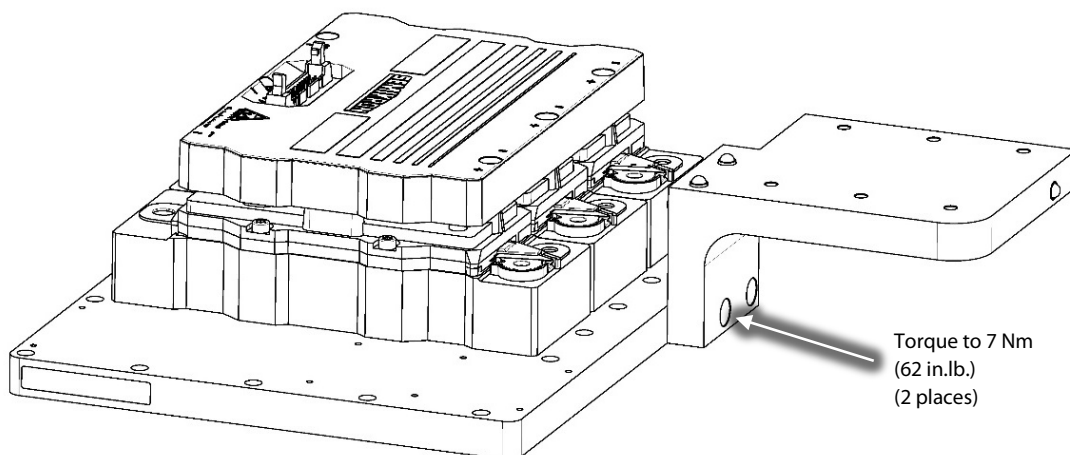

Figure 19 – SCR Cooling Manifold Removal

32. Remove the HV DC-DC from the Inverter cooling manifold if it is to be reused. Refer to Figure 20 (DC-DC Removal).

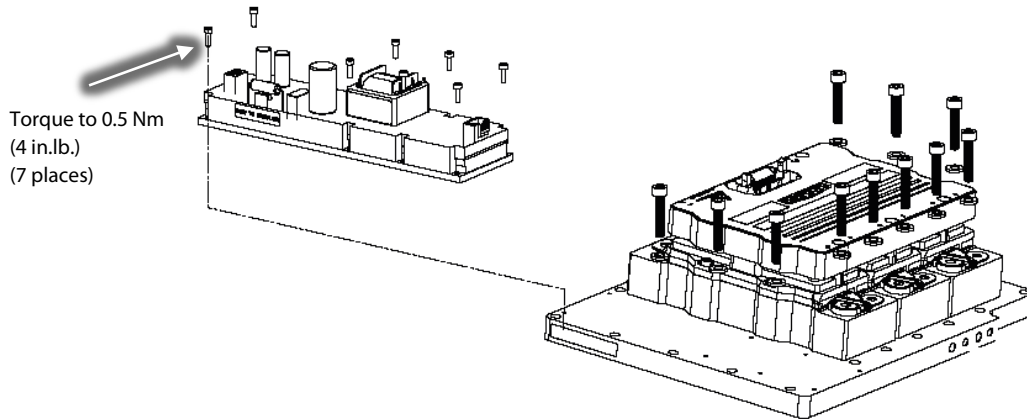

Figure 20 – DC-DC Removal

4 - INVERTER ASSEMBLY Installation Instruction:

1. Apply O-Lube to the O-rings provided and install them into the SCR cooling manifold. Refer to Figure 21 (SCR Cooling Manifold O-ring Installation).

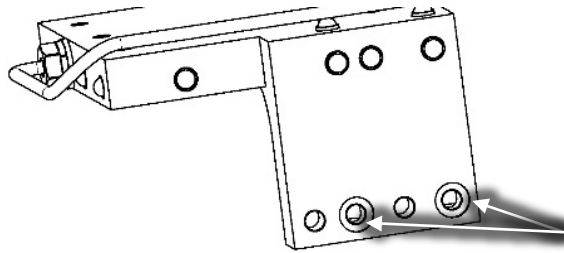

Figure 21 –SCR Cooling Manifold O-ring Installation

2. Reinstall the SCR cooling manifold to the Inverter cooling manifold reusing the two (2) fasteners and torque to specification. Refer to Figure 22 (SCR Cooling Manifold Installation).
3. Reinstall the insulation onto the backside of the SCR Cooling Manifold.

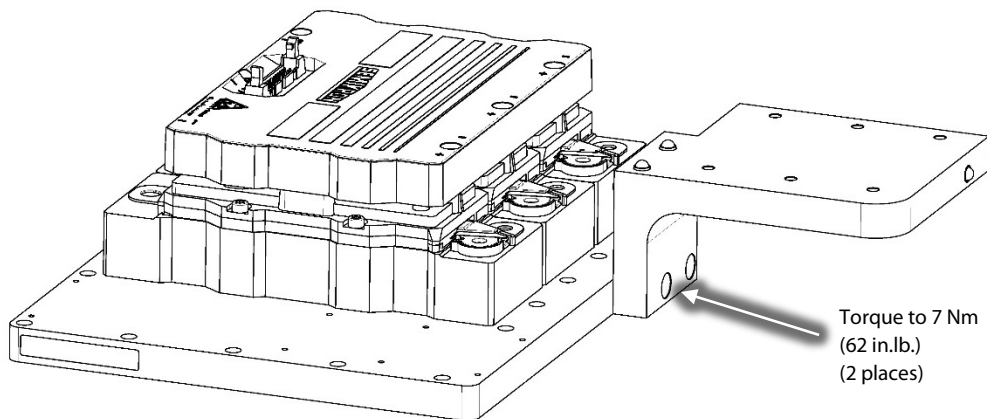

Figure 22 – SCR Cooling Manifold Installation

4. Clean the O-ring grooves in the compressor housing.
5. Apply O-Lube to the Inverter O-ring provided and place the O-ring in the compressor housing groove.
6. Install the small O-ring into the motor cooling port.

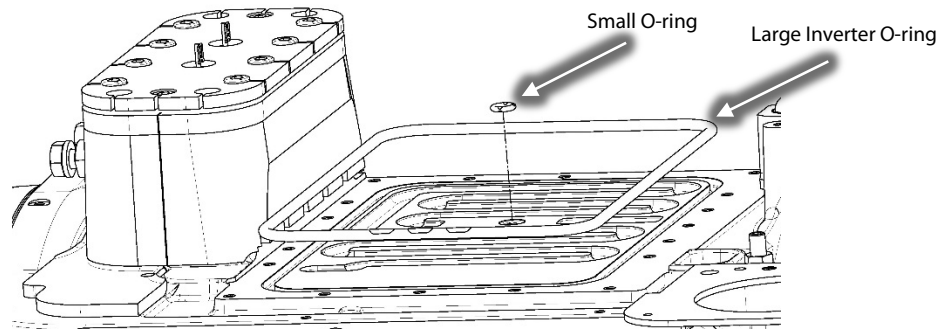

Figure 23 – Inverter O-ring Installation

7. Remove the backing material from the cooling manifold of the new Inverter. Prevent damage to sealing surface.
8. Carefully, install the Inverter on the compressor housing with the SCR temperature sensor cable run underneath the SCR cooling manifold.

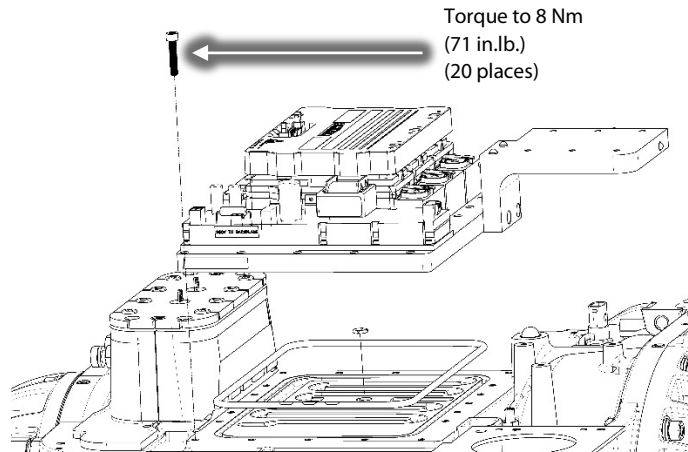

Figure 24 – Inverter Installation

9. Install the provided Inverter fasteners in a diagonal pattern and torque to 3 Nm (27 in.lb.) on the first pass then to 8 Nm (71 in.lb.) on the second pass. Refer to Figure 25 (Inverter Screw Locations).

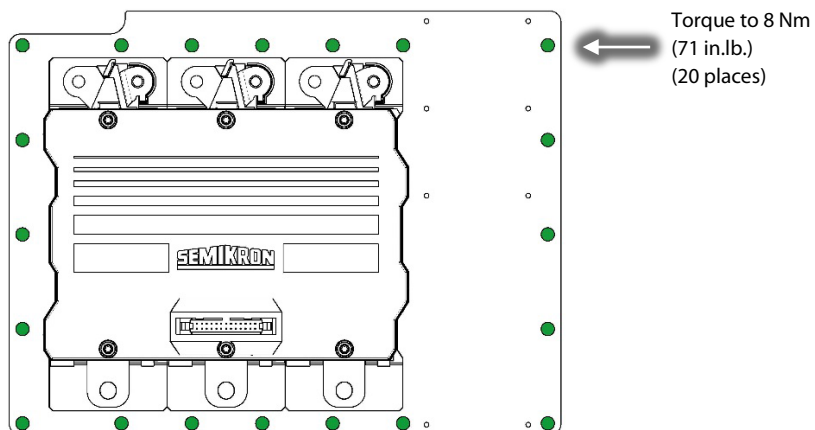

Figure 25 – Inverter Screw Locations

10. Leak test and evacuate the compressor in accordance with industry standards.
11. Reconnect the SCR temperature sensor, discharge P/T sensor, IGV motor connection, and the suction P/T sensor.
12. Install the Motor Bus Bars between the motor high power feed throughs and the Inverter and torque to specification. Install the new Motor Bus Bars on the Inverter and torque to specification. Refer to Figure 26 (Motor Bus Bar Installation).

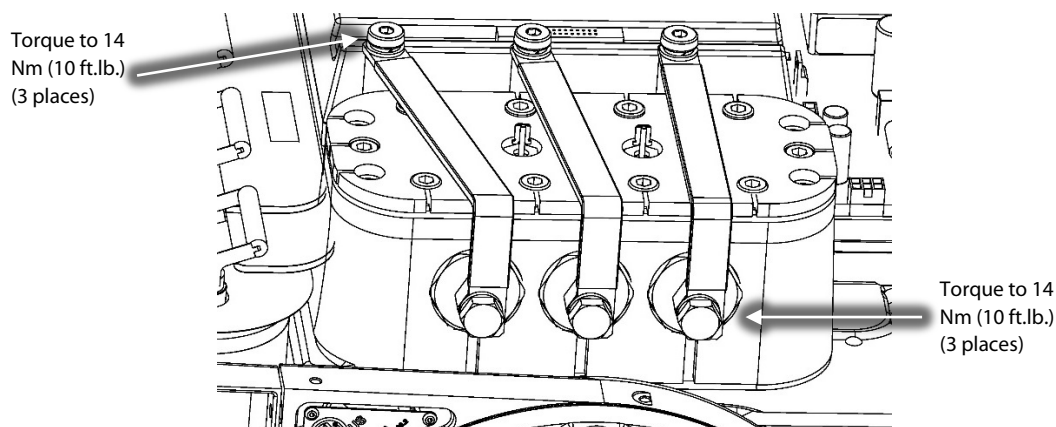

Figure 26 – Motor Bus Bar Installation

13. Reinstall the HV DC-DC converter to the Inverter cooling manifold and torque to specification. Refer to Figure 20 (DC-DC Removal).
14. Reinstall the DC Bus Bar and capacitor assembly over the Inverter and torque to specification. Refer to Figure 13 (Capacitor Assembly Removal).
15. Reconnect the snubber capacitors to the Inverter noting the leg orientation and torque to specification. Starting from the DC Bus Capacitor side, torque to specification. Refer to Figure 11 (Snubber Capacitor Removal).
16. Place the capacitor membrane foil side down, underneath the main compressor housing and then reinstall the nylon nuts to the base of the DC capacitor assembly, under the main compressor housing and torque to specification. Refer to Figure 12 (Capacitor Nut Removal).
17. Reconnect the DC+ and DC- of the Soft Start harness from the DC bus assembly noting the orientation and torque to specification. Refer to Figure 10 (Soft Start Harness Removal).
18. Reconnect the DC Bus Bars to the SCRs and torque to specification. Refer to Figure 7 (DC Bus Bar Removal).
19. Reconnect the DC Bus Bars the DC Bus and torque to specification. Refer to Figure 7 (DC Bus Bar Removal).
20. Reconnect all electrical connections to the HV DC-DC converter. Refer to Figure 16 (DC-DC Harness Removal).
21. Reinstall the Mylar in the middle of the Terminal Block. Refer to Figure 27 (Main Power Mylar Insertion).

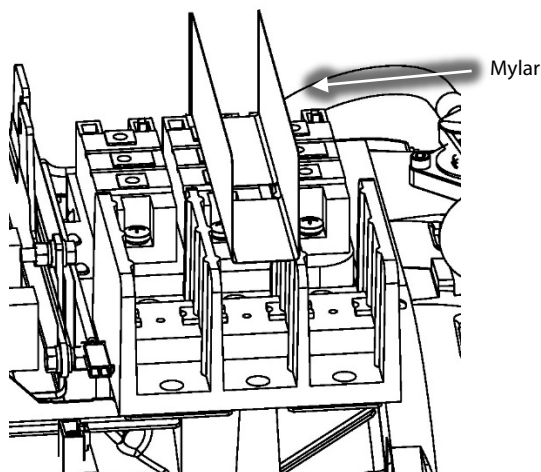

Figure 27 – Main Power Mylar Insertion

22. Reinstall the three (3) fuse assemblies to the SCRs and the Mains Input Terminal Block. Torque the fasteners of the fuse assemblies to specification. Refer to Figure 28 (Fuse Assembly Installation).

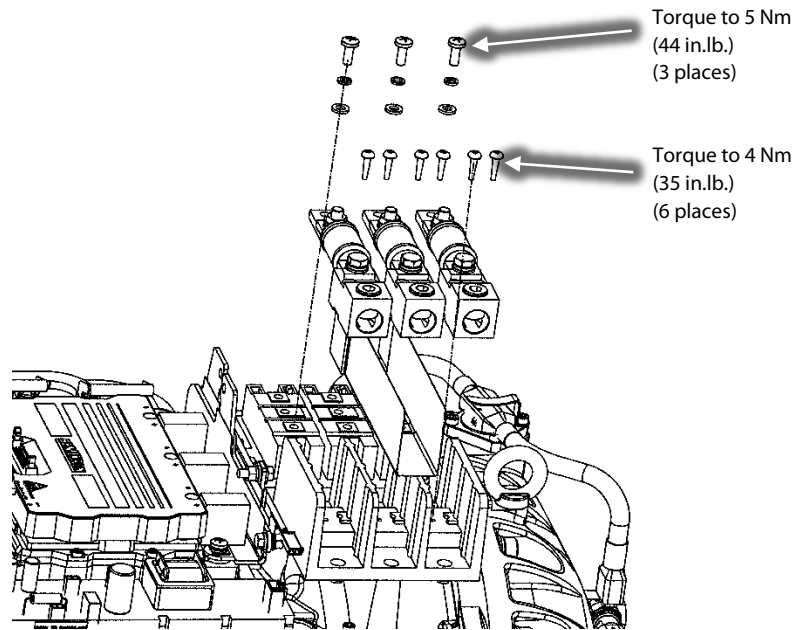
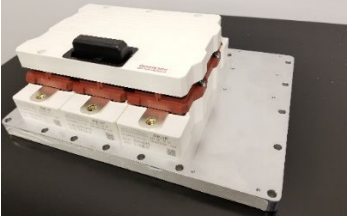

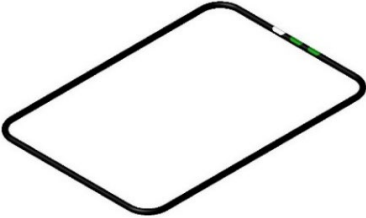





Figure 28 – Fuse Assembly Installation

23. Connect the SCR Gate cable harness to the SCRs noting its orientation.  
 24. Reconnect all wiring harnesses to the Soft Start.  
 25. Place the Soft Start into mounting position, secure to the compressor, and torque to specification.  
 26. Reroute and connect the Soft Start ground wire to the ground post on the compressor housing at 3-phase connection point and torque to specification.  
 27. Install top side covers.  
 28. Charge the compressor with refrigerant.

Torque Values	
Component	Torque Value
SCR cooling manifold to Inverter cooling manifold	7 Nm (62 in.lb.)
Soft Start Mounting Screws	5 Nm (44 in.lb.)
DC-DC Mounting Screws	0.5 Nm (4 in.lb.)
Inverter to compressor housing	8 Nm (71 in.lb.)
Motor Bus Bar to motor	14 Nm (10 ft.lb.)
Motor Bus Bar to Inverter	14 Nm (10 ft.lb.)
Soft Start DC+ & DC- to DC bus	10 Nm (7 ft.lb.)
Snubber capacitors to Inverter	7 Nm (62 in.lb.)
Nylon Nuts	7 Nm (62 in.lb.)
DC Bus Bar to DC bus	10 Nm (7 ft.lb.)
DC Bus Bars to SCR	5 Nm (44 in.lb.)
Fuse to SCR	5 Nm (44 in.lb.)
Fuse to Terminal Block	4 Nm (35 in.lb.)
Ground post top nut	10 Nm (7 ft.lb.)
Ground post second nut	7 Nm (62 in.lb.)

5 - Kit Contents

KIT NAME: KIT – IGBT ASSEMBLY SEMIKRON 613 SERIES TT300/TG230 G SERIES		
KIT #: 100043-13		
QTY	Part(s) Description	Picture(s)
1	IGBT ASSEMBLY	
2	O-RING #2-011	
1	O-RING #2-109	
1	O-RING #2-377	
1	LUBRICATION-SUPER-O-LUBE-2G	
20	WASHER M6 FLAT	
20	SCREW M6X30 S/HD CAP	

Danfoss can accept no responsibility for possible errors in catalogues, brochures and other printed material. Danfoss reserves the right to alter its products without notice. This also applies to products already on order provided that such alterations can be made without subsequential changes being necessary in specifications already agreed. All trademarks in this material are property of the respective companies. Danfoss and the Danfoss logotype are trademarks of Danfoss A/S. All rights reserved.