

# KIT COVERS – FOAM & MEMBRANE

100385-1.



**Installation and servicing of Danfoss Turbocor® compressors by qualified and product trained personnel only. Follow these instructions and sound refrigeration/electrical/servicing practices relating to installation, commissioning, maintenance and service.**

<p>Consult the appropriate Danfoss Turbocor Compressors Inc. (DTC) Service Manual on <a href="http://turbocor.danfoss.com">turbocor.danfoss.com</a> for detailed service instructions.</p>	<p><b>Never power compressor without covers in place and secured.</b></p> <p><b>Removing the mains input cover will expose you to a voltage hazard of up to 575V. Ensure the mains input power is off and locked out before removing cover.</b></p> <p><b>Before removing top cover, wait at least 20 minutes after isolating AC power to allow the high voltage capacitors to discharge.</b></p>	<p>Always wear appropriately rated safety equipment when working around equipment and/or components energized with high voltage.</p> <p><b>This equipment contains hazardous voltages that can cause serious injury or death.</b></p>	<p><b>Recover all refrigerant from compressor in accordance with local codes and ensure pressure is fully vented before the removal of refrigerant containing components.</b></p>
--	---	---	---

## 1 - Introduction:

COVER KIT Removal and Installation Instructions.

**Note:** Care must be taken in removal and installation of the covers to prevent the fasteners from falling into the power electronic compartment. Dropping cover fasteners can cause a short circuit, energized components to explode, and damage to the power electronic parts of the compressor. Place the fasteners aside carefully after positioning the covers to minimize the risk of fasteners falling in to the power electronic areas.

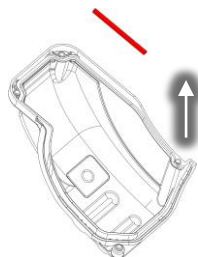
## 2 - Suggested Tools:

The following tools are suggested:

- Philips/torx screwdriver
- Socket/wrench

## 3 - Removal Instructions:

1. Isolate compressor power as described in Section "1.7 Electrical Isolation" of the TT/TG Service Manual.
2. Release the fasteners that secure the Mains Input Cover and remove the cover.
3. Remove the "D" seal from the cover. Refer to Figure 1 (Mains Cover "D" Seal Removal).

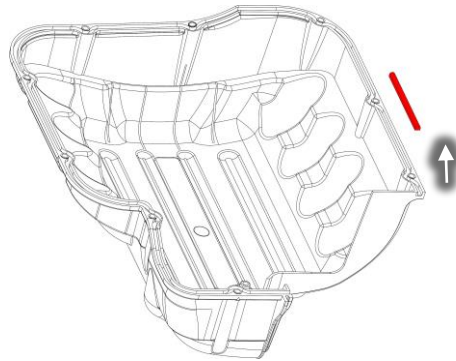


**Figure 1 – Mains Cover "D" Seal Removal**

4. Using an appropriately rated volt meter, confirm that the AC voltage is isolated.
5. Wait at least 20 minutes for the DC bus capacitors to discharge.
6. Release the fasteners that secure the Top Cover and remove the cover, taking particular care not to touch ANY components underneath.
7. Using an appropriately rated volt meter, check the DC bus bars for voltage level. If the voltage is above 5VDC, wait five (5) minutes and recheck until 5VDC or below is achieved.

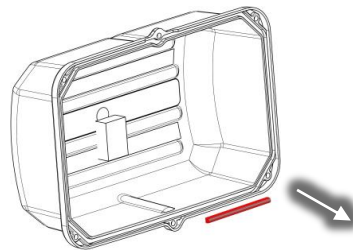
**DANGER:** Do NOT touch any components when removing the top cover. This is particularly true for compressors with CE covers because they are coated on the outside for the express purpose of being conductive.

8. Remove the "D" seal from the cover. Refer to Figure 2 (Top Cover "D" Seal Removal).



**Figure 2 – Top Cover "D" Seal Removal**

9. Release the fasteners that secure the Service Side Cover and remove the cover.
10. Remove the "D" seal from the cover. Note the position of the gap where the two (2) seal ends meet. Refer to Figure 3 (Service Side Cover "D" Seal Removal).



**Figure 3 – Service Side Cover "D" Seal Removal**

11. Release the fasteners that secure the Capacitor Cover and remove the cover.
12. Remove the nylon nuts under the capacitor assembly and remove the capacitor relief membrane.

---

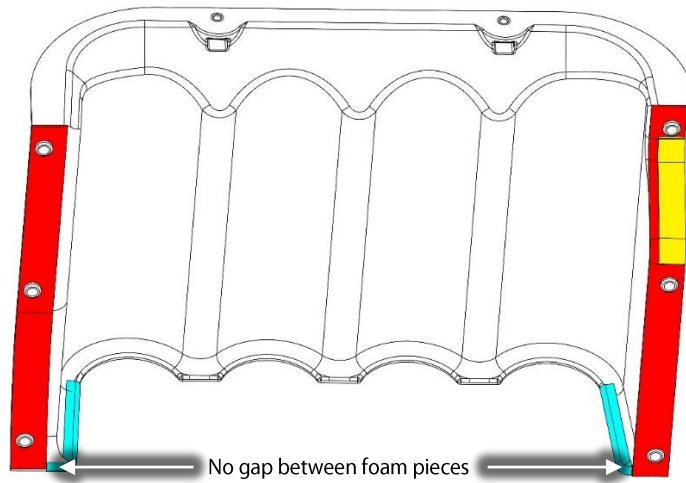
#### 4 - Installation Instruction:

**NOTE 1:** The colors shown in the following figures are not representative of the actual items. Various colors are used to highlight the different foam seals required for this installation process.

**NOTE 2:** When applying the longer foam pieces to the covers, only peel a small amount of the paper backing at a time. This will prevent accidental adhesion during application.

## **CAPACITOR COVER**

The completed foam installation for the Capacitor Cover should resemble the illustration in Figure 4 (Completed Capacitor Cover Foam Installation).

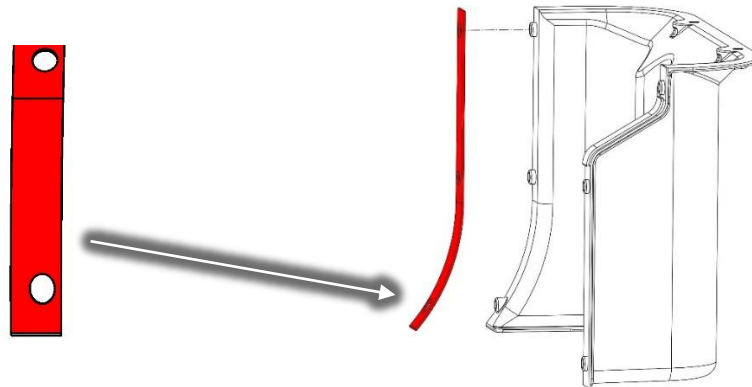


**Figure 4 – Completed Capacitor Cover Foam Installation**

1. Ensure that no residue remains on the compressor housing contact surfaces.
2. Clean the Capacitor Cover contact surfaces with an alcohol wipe or equivalent.

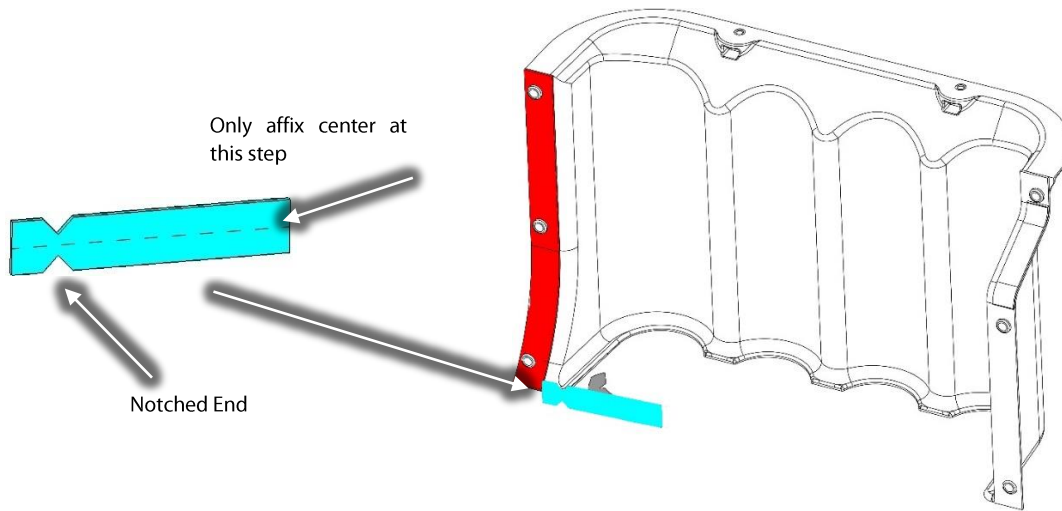
**NOTE:** The cleaned surfaces must be completely dry before any foam is installed.

3. Remove a small portion of the adhesive backing at the end and install the shorter Capacitor Side Cover Sealing Foam Bottom Right. The bottom hole is slightly oval shaped. Refer to Figure 5.



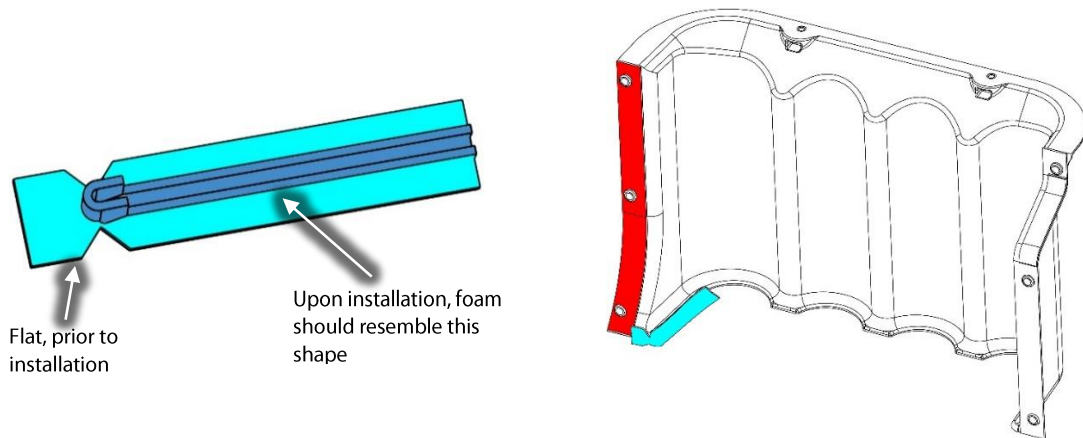
**Figure 5 – Capacitor Cover Right Side Foam Installation**

- Obtain the longer (approximately 83 mm long) Capacitor Cover Sealing Foam Lower Right and remove a small portion of the adhesive backing at the notched end and install the shorter Capacitor Cover Sealing Foam Lower Right. It is important to begin where this foam meets the previously installed foam. This new foam must be installed against the existing foam. Refer to Figure 6 (Capacitor Cover Sealing Foam Lower Right).



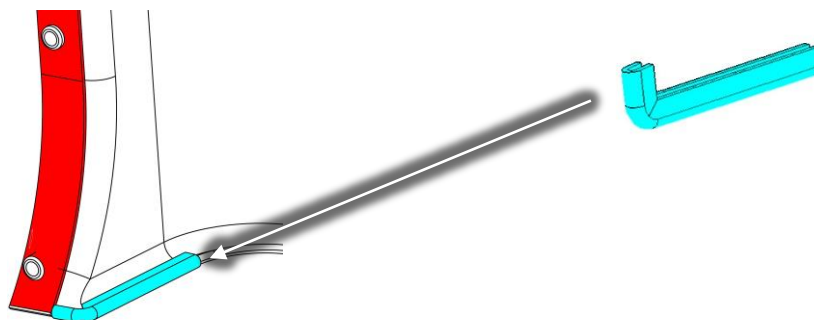
**Figure 6 – Capacitor Cover Sealing Foam Lower Right**

- Carefully work the foam around the cover and only affix the center portion of the foam at this time. Refer to Figure 7 (Foam Wrap) for this and the following step.
- Carefully wrap the foam around the lip of the cover and press firmly.



**Figure 7 – Foam Wrap**

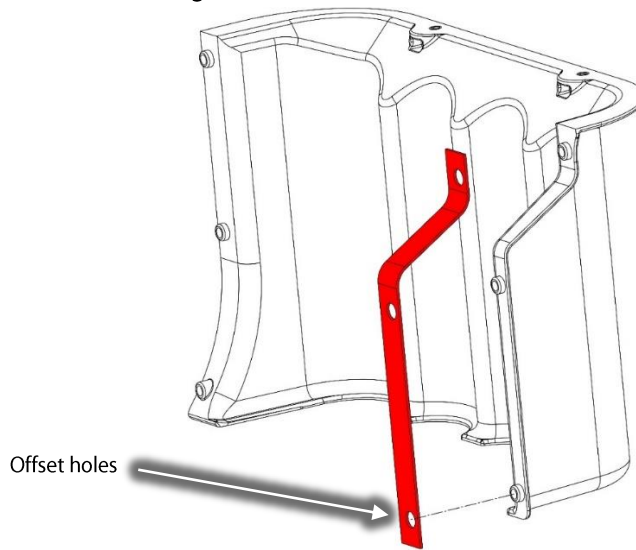
- When the foam is completely installed, it should be formed like the foam illustrated in Figure 8 (Capacitor Cover Sealing Foam Lower Right Completion).



**Figure 8 – Capacitor Cover Sealing Foam Lower Right Completion**

- Remove a small portion of the adhesive backing at the end and install the Capacitor Side Cover Sealing Foam Left. Refer to Figure 9.

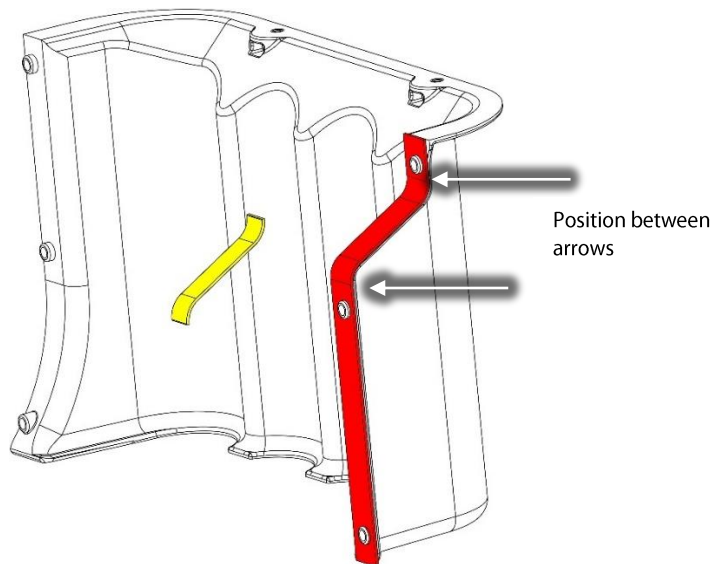
**NOTE:** The holes will be offset to the right.



**Figure 9 – Capacitor Cover Left Side Foam Installation**

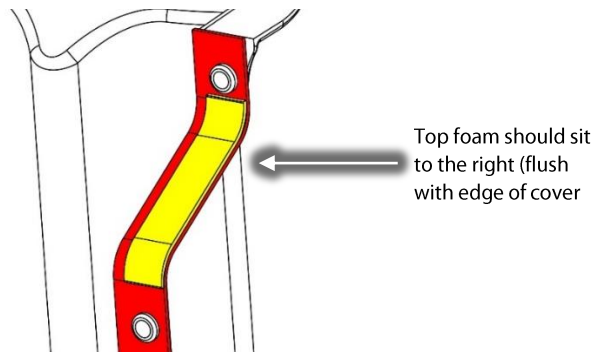
- Remove a small portion of the adhesive backing at the end and install the Main Housing Sealing Foam, Capacitor Side. Position as indicated in Figure 10 (Capacitor Cover Left Side Short Foam Installation) and Figure 11 (Capacitor Cover Left Side Short Foam Installed).

**NOTE:** This foam will be installed directly over the Capacitor Left Side Foam.



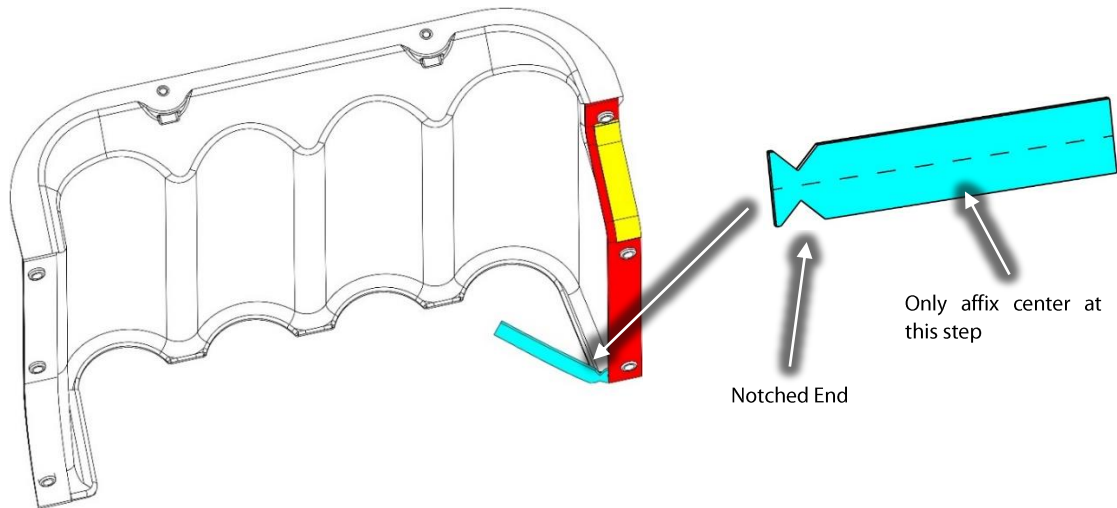
**Figure 10 – Capacitor Cover Left Side Short Foam Installation**

10. The sealing foam should be positioned as illustrated in Figure 11 (Capacitor Cover Left Side Short Foam Installed).



**Figure 11 – Capacitor Cover Left Side Short Foam Installed**

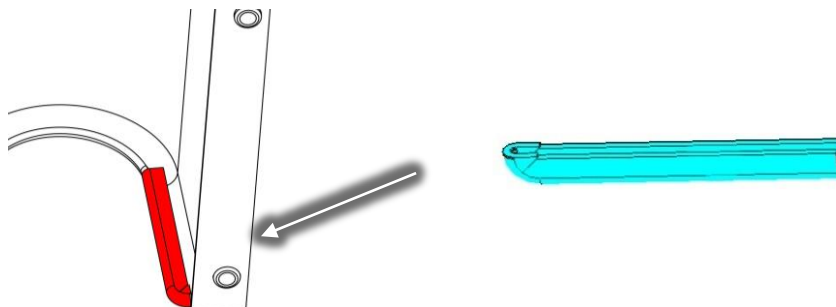
11. Obtain the shorter (approximately 76 mm long) Capacitor Side Cover Sealing Foam Bottom Left and remove a small portion of the adhesive backing at the notched end and install the Capacitor Side Cover Sealing Foam Bottom Left. It is important to begin where this foam meets the previously installed foam. This new foam must be installed against the existing foam. Refer to Figure 12 (Capacitor Cover Sealing Foam Lower Left).



**Figure 12 – Capacitor Cover Sealing Foam Lower Left**

12. Carefully work the foam around the cover and only affix the center portion of the foam at this time.

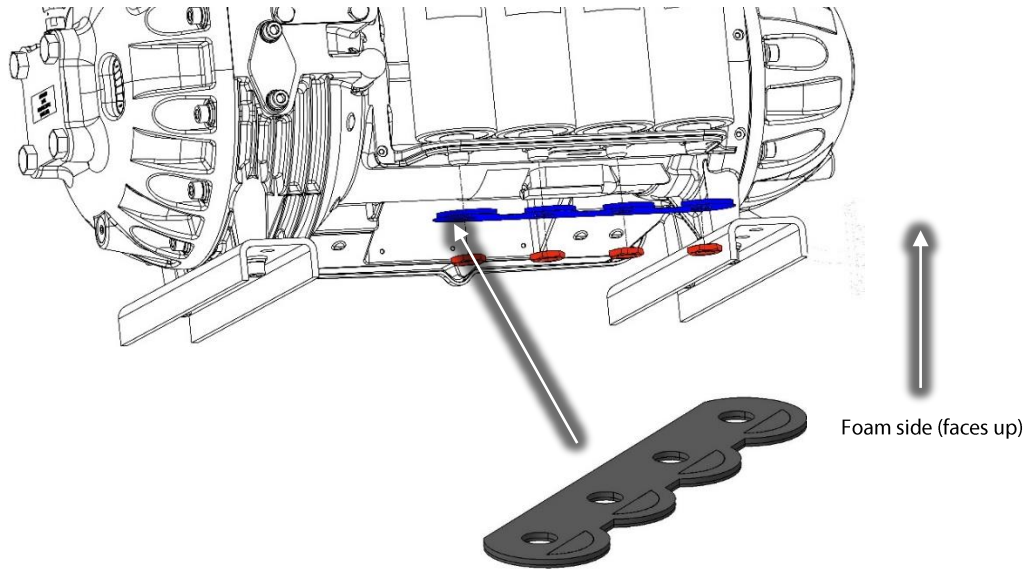
13. Carefully wrap the foam around the lip of the cover and press firmly. Refer to Figure 13 (Capacitor Cover Sealing Foam Lower Left Completion).



**Figure 13 – Capacitor Cover Sealing Foam Lower Left Completion**

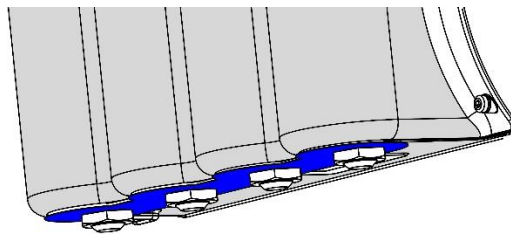


14. Install the new capacitor relief membrane over the nylon threads under the compressor housing, below the capacitors. The membrane is made up of a closed-cell foam and a PVC backing. The foam side should be facing up. Refer to Figure 14 (Relief Membrane Orientation) for an illustration.

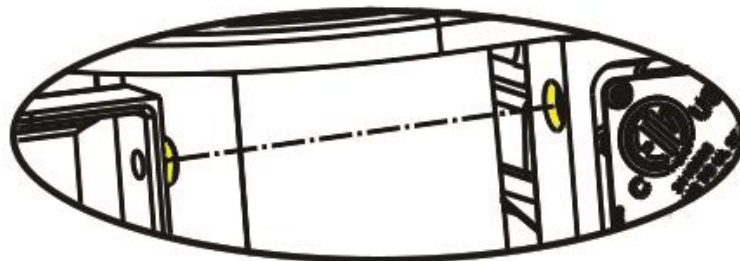


**Figure 14 – Relief Membrane Orientation**

15. Install the new nylon nuts to the base of the DC capacitor assembly, under the main compressor housing and torque to 7 Nm (62 in.lb.).
16. Place the Capacitor Cover and loosely secure it with the M5X15 fasteners. The bottom of the cover should rest just above the Relief Membrane. Refer to Figure 15 (Capacitor Cover Position) for an illustration. Additionally, the cover should line up and sit in the recessed holes in the compressor housing. Refer to Figure 16 (Recessed Holes) for an illustration.

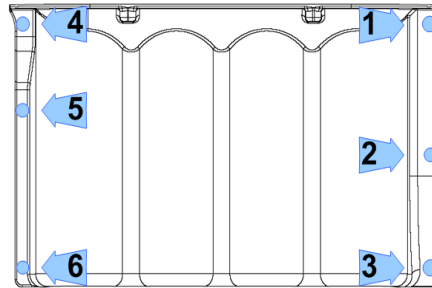


**Figure 15 – Capacitor Cover Position**



**Figure 16 – Recessed Holes**

- Place the long fastener (M5X20) and flat washer in position number three (3) shown in Figure 17 – Capacitor Cover Torque Sequence. Follow the sequence twice. The first time, only tighten the fasteners half way down to allow for adjustment. Then tighten all Capacitor Cover fasteners according to the sequence in Figure 17 Capacitor Cover Torque Sequence. Torque all Capacitor Cover fasteners to 13 in.lb. on the second pass.

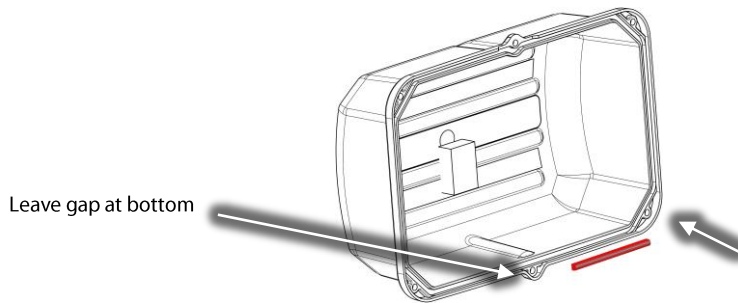


**Figure 17 - Capacitor Cover Torque Sequence**

**SERVICE SIDE COVER**

**NOTE:** It is best to not cut the “D” Seal before installation. This will avoid the seal being too short after installation.

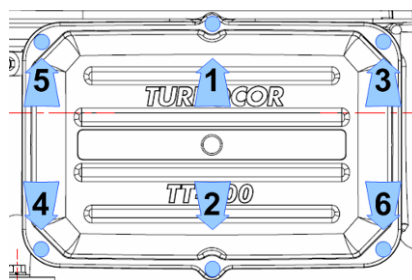
- Ensure that no residue remains on the covers or compressor housing contact surfaces.
- Install the new “D” seal into the Service Side Cover. Begin at the bottom just to the right or left of the center. Work the seal around until you reach the other end and have a small gap at the bottom. Cut the seal (90 degrees from the side of the seal). Refer to Figure 18 (New “D” Seal Installation – Capacitor Cover).



**Figure 18 – New “D” Seal Installation – Capacitor Cover**

**NOTE:** The gap between the two (2) ends should be no greater than 4.8mm (3/16”). It is recommended that a small gap be present to allow moisture to escape. In normal environmental conditions, little to no moisture should occur, but harsh environmental conditions could generate a small amount of moisture.

- Go back and gently press the seal to ensure it is properly seated in all locations.
- Place the Service Side Cover and secure it with the fasteners according to the sequence shown in Figure 19 (Service Side Cover Torque Sequence).
- Follow the sequence twice. The first time, only tighten the fasteners half way down to allow for adjustment. Torque to 13 in.lb. on the second pass.



**Figure 19 – Service Side Cover Torque Sequence**

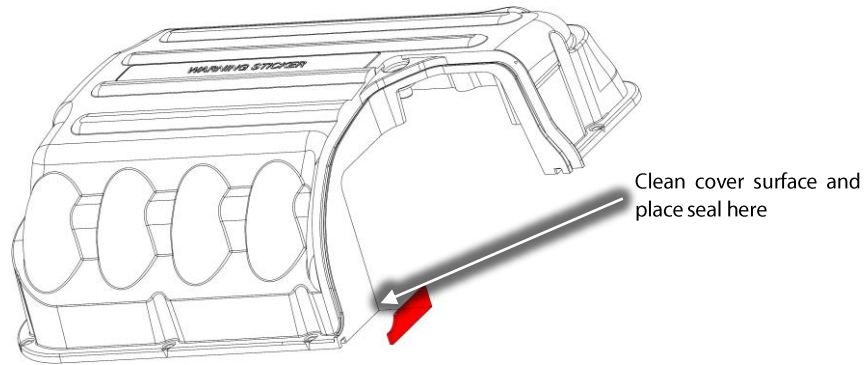


**TOP COVER**

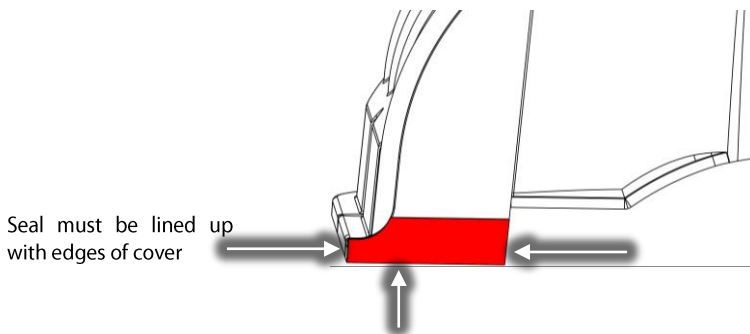
1. Ensure that no residue remains on the covers or compressor housing contact surfaces.
2. Clean the Top Cover contact surfaces with an alcohol wipe or equivalent.

**NOTE:** The cleaned surfaces must be completely dry before the foam is installed.

3. Remove the adhesive backing and carefully install the Top Cover Sealing Foam. The foam must be aligned with the edges of the cover. Refer to Figures 20 (Top Cover Foam Installation) and 21 (Top Cover Foam Installed).

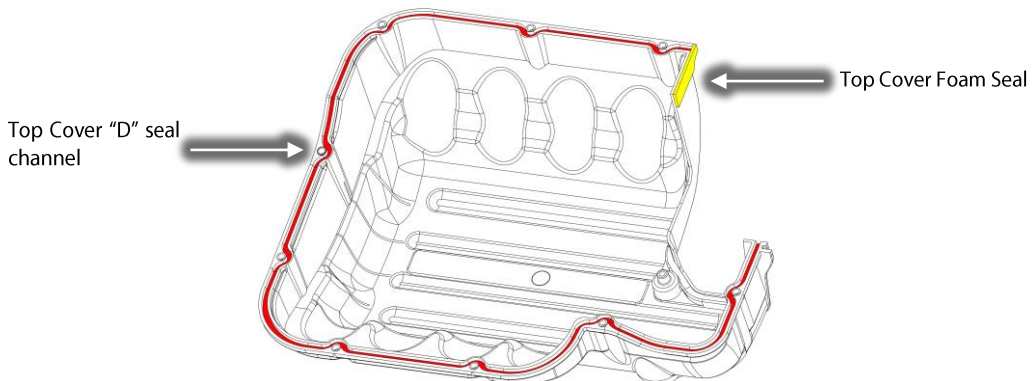


**Figure 20 – Top Cover Foam Installation**



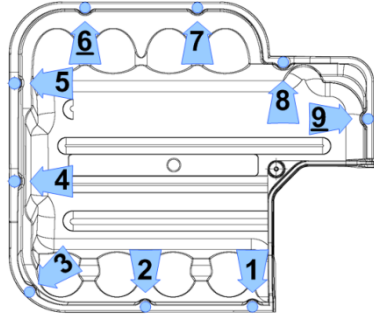
**Figure 21 – Top Cover Foam Installed**

4. Beginning on the end where the new foam was installed, place the “D” seal into the groove of the cover. Make sure the end of the seal is up against the foam.
5. When at the other end of the cover, cut the “D” seal flush with the edge of the cover.
6. Go back and gently press the seal to ensure it is properly seated in all locations. Refer to Figure 22 (Top Cover Underside) for an illustration of the seal location under the cover.



**Figure 22 – Top Cover Underside**

- Place the Top Cover and secure it with the M5x15 fasteners according to the sequence shown in Figure 23 Top Cover Torque Sequence. Follow the sequence twice. The first time, only tighten the fasteners half way down to allow for adjustments. Torque to 13 in.lb. on the second pass.



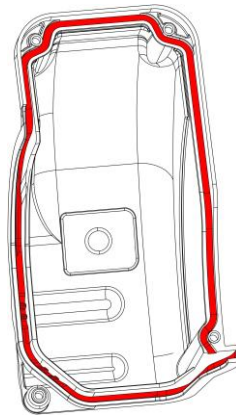
**Figure 23 – Top Cover Torque Sequence**

### **MAINS COVER**

- Ensure that no residue remains on the compressor housing contact surfaces.
- Clean the Mains Cover contact surfaces with an alcohol wipe or equivalent.

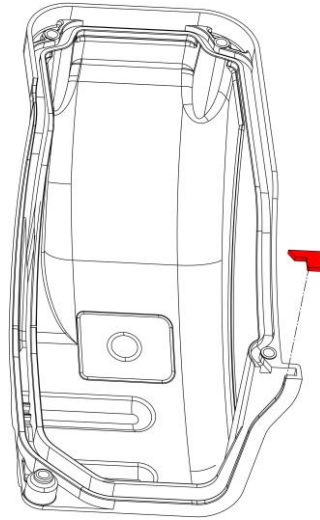
**NOTE:** The cleaned surfaces must be completely dry before the foam is installed.

- Beginning on either end, place the “D” seal into the groove of the cover. Work the seal around until it reaches the other end. Make sure the end of the seal is flush with the end of the groove in the cover, then cut the seal. Refer to Figure 24 (Mains Cover Underside) for an illustration of the seal location under the cover.

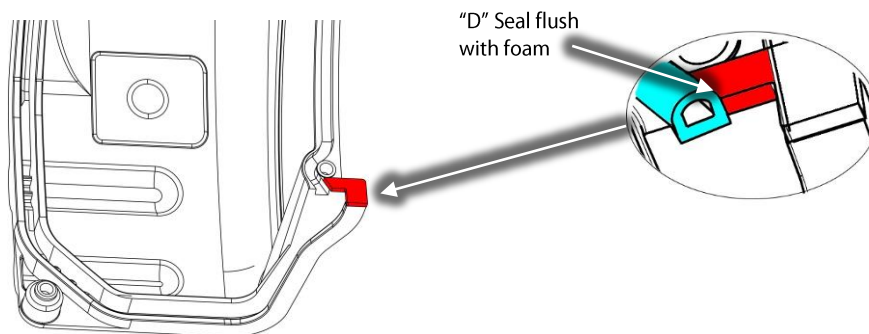


**Figure 24 – Mains Cover Underside**

- Remove the adhesive backing and carefully install the Top Cover Sealing Foam. The foam must be aligned with the edges of the cover. Refer to Figures 25 (Installing Mains Cover Foam) and 26 (Mains Cover Foam Installed). If cut properly, the seal installed in the previous step should rest against the foam.

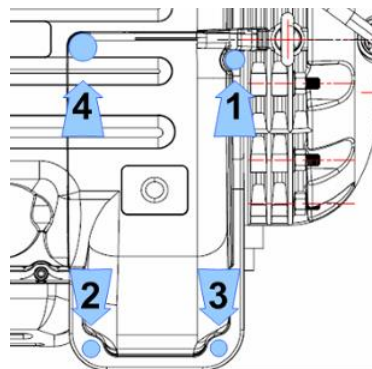


**Figure 25 – Installing Mains Cover Foam**



**Figure 26 – Mains Cover Foam Installed**




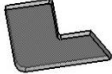
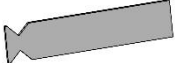








- Place the Mains Input Cover and secure it with the M5x15 fasteners. Torque to 13 in.lb. according to the sequence shown in Figure 27 (Mains Cover Torque Sequence).



**Figure 27 – Mains Cover Torque Sequence**

- Re-connect compressor power.

5 - Kit Contents

QTY	Part(s) Description	Picture(s)
1	TOP COVER SEALING FOAM	
1	MAIN HOUSING SEALING FOAM, CAPACITOR SIDE	
12 ft.	SEAL-HOLLOW - D - SILICONE PROFILE- LAUREN - CONDUCTIVE	
1	MAINS INPUT SEALING FOAM	
1	CAPACITOR SIDE COVER SEALING FOAM BOTTOM RIGHT	
1	CAPACITOR SIDE COVER SEALING FOAM BOTTOM LEFT	
1	CAPACITOR SIDE COVER SEALING FOAM LEFT	
1	CAPACITOR SIDE COVER SEALING FOAM RIGHT	
1	MEMBRANE ASSEMBLY – CAPACITOR RELIEF	
4	NUT, HEX, JAM, 3/4" -10 NC, NYLON	
1	WASHER M5 FLAT	
1	SCREW, M5x20 PAN, HEAD	
24	SCREW, DOUBLE SEMS M5X15, PAN HEAD	

Danfoss can accept no responsibility for possible errors in catalogues, brochures and other printed material. Danfoss reserves the right to alter its products without notice. This also applies to products already on order provided that such alterations can be made without subsequential changes being necessary in specifications already agreed. All trademarks in this material are property of the respective companies. Danfoss and the Danfoss logotype are trademarks of Danfoss A/S. All rights reserved.