

KIT DC-DC

110016, 110107, & 110108.

 <p>Installation and servicing of Danfoss Turbocor® compressors by qualified and product trained personnel only. Follow these instructions and sound refrigeration/electrical/servicing practices relating to installation, commissioning, maintenance and service.</p>			
<p>Consult the appropriate Danfoss Turbocor Compressors Inc. (DTC) Service Manual on turbocoroem.com for detailed service instructions.</p>	<p>Never power compressor without covers in place and secured.</p> <p>Opening the drive panel will expose you to a voltage hazard of up to 575V AC and 900V DC. Ensure the mains input power is off and locked out before opening panel.</p> <p>Before opening the drive panel, wait at least 20 minutes after isolating AC power to allow the high voltage capacitors to discharge.</p>	<p>Always wear appropriately rated safety equipment when working around equipment and/or components energized with high voltage.</p> <p>This equipment contains hazardous voltages that can cause serious injury or death.</p>	<p>Recover all refrigerant from compressor in accordance with local codes and ensure pressure is fully vented before the removal of refrigerant containing components.</p>

1 - Introduction

VTT/VTX DC-DC/FAN replacement.

Please refer to our Service Manual for details regarding the replacement of the DC-DC or DC-DC Fan.

We have made the **VTT/VTX Service Manual** available to anyone. To access the manual, you may scan the applicable QR code below or you may go to our DTC website at www.turbocoroem.com. At the top of the page there is a pull-down menu called "Quick Links." Click this menu and select the appropriate service manual.

Refer to the applicable QR code below to download the VTT/VTX Service Manual.

English



Chinese



Danfoss can accept no responsibility for possible errors in catalogues, brochures and other printed material. Danfoss reserves the right to alter its products without notice. This also applies to products already on order provided that such alterations can be made without consequential changes being necessary in specifications already agreed. All trademarks in this material are property of the respective companies. Danfoss and the Danfoss logotype are trademarks of Danfoss A/S. All rights reserved.

2 - DC-DC CONVERTER Removal Instructions

1. Isolate VTT/VTX power as described in Section "Electrical Isolation of the VFD" of the Service Manual (M-SV-VT-001).
2. Open the panel containing the DC-DC.
3. Removal all connectors/wires from the DC-DC.
4. Remove the DC-DC from the panel.

DC-DC Fan Only

NOTE: The color of the board is different depending on the revision.

1. Remove the fan fasteners.
2. Remove the fan connector.
3. Remove fan from the DC-DC.

3 - DCDC CONVERTER Installation Instructions

DC-DC Fan Only

1. Install the fan in the proper direction.

NOTE: There is an arrow in the fan housing that should be pointing towards the DC-DC.

2. Install the fan connector.
3. Return the compressor to normal operation.

NOTE: There is no difference between early revisions (A and B) and revisions C and later DC-DCs with the exception of the connectors illustrated in this instruction. If replacing a Revision A or B, with a Revision C or Later, the Molex connector on the existing harness will need to be removed. Follow the instructions below based upon what DC-DC version is to be installed.

DC-DC Converter (Revisions A and B)

1. Install the DC-DC in the panel.
2. Connect the HV DC input cable to J1; 24 VDC output cable to J4; and 250VDC output cable to J2.
3. Connect the grounding wires to M4, M5, J6, and J7.
4. Close the panel.
5. Return the compressor to normal operation.

DC-DC Converter (Revisions C and Later)

1. Install the DC-DC in the panel.
2. Connect the HV DC input cable to J1.
3. Cut the Molex connectors (on the DC/DC fan side) from the 24 VDC and 250VDC output cables. Strip 7-8 mm (9/32" – 9/16") of insulation off the wire ends.
4. Wire the 24 VDC output cable into J4, and the 250VDC output cable into J2. Note the wire colors in the wiring diagram in Figure 1.
5. Tighten each connection with a flat-blade screwdriver.
6. Close the panel.
7. Return the compressor to normal operation.

Danfoss can accept no responsibility for possible errors in catalogues, brochures and other printed material. Danfoss reserves the right to alter its products without notice. This also applies to products already on order provided that such alterations can be made without subsequential changes being necessary in specifications already agreed. All trademarks in this material are property of the respective companies. Danfoss and the Danfoss logotype are trademarks of Danfoss A/S. All rights reserved.

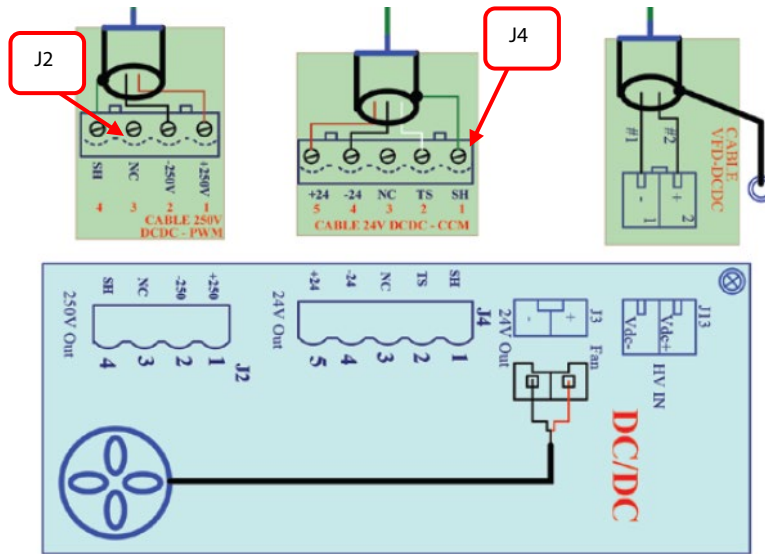

Figure 1 – Wiring connections for 24 VDC and 250 VDC cables, Revision C and later





4 - Kit Contents

Note: Any part numbers included in the kit contents are internal part numbers only. Please refer to our Spare Parts Manuals for any kit part numbers.

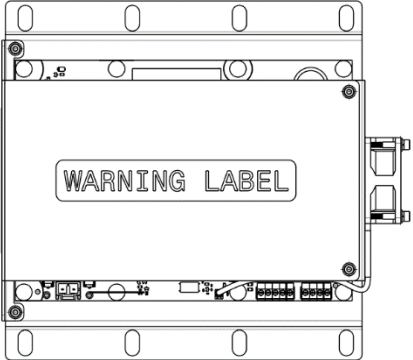
Kit numbers	Compressor models	
110016	VTT	
QTY	Part(s) Description	Picture(s)
1	DC-DC (Revisions A and B)	

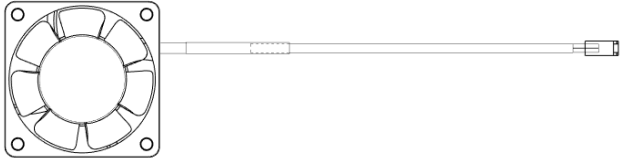
Danfoss can accept no responsibility for possible errors in catalogues, brochures and other printed material. Danfoss reserves the right to alter its products without notice. This also applies to products already on order provided that such alterations can be made without consequential changes being necessary in specifications already agreed. All trademarks in this material are property of the respective companies. Danfoss and the Danfoss logotype are trademarks of Danfoss A/S. All rights reserved.

Kit numbers	Compressor models	
110107	VTT/VTX	
QTY	Part(s) Description	Picture(s)
1	DC-DC (VTT Revisions C and Later) DC-DC (VTX all revisions)	

Kit numbers	Compressor models	
110108	VTT/VTX	
QTY	Part(s) Description	Picture(s)
1	DC-DC FAN ONLY	
4	SCREW, M4 – 900036	
4	WASHER, M4 FLAT – 940203	
4	WASHER, M4 SPLIT – 940204	

Danfoss can accept no responsibility for possible errors in catalogues, brochures and other printed material. Danfoss reserves the right to alter its products without notice. This also applies to products already on order provided that such alterations can be made without subsequential changes being necessary in specifications already agreed. All trademarks in this material are property of the respective companies. Danfoss and the Danfoss logotype are trademarks of Danfoss A/S. All rights reserved.