

Spare Parts Selection Guide - Revision L

Danfoss Turbocor® Twin-Turbine Centrifugal Compressors





THIS PAGE INTENTIONALLY LEFT BLANK

Table of Contents

- Table of Contents** **3**
- Chapter 1.0 Introduction** **11**
 - 1.1 Organization 11
 - 1.2 PDF Navigation 11
 - 1.3 Nomenclature 11
- Chapter 2.0 External Components** **15**
 - 2.1 Compressor Controller Cable Harness 19
 - 2.2 Cooling Adapter 20
 - 2.3 Housing End Cap 21
 - 2.4 Second Stage Housing 22
 - 2.5 Interstage Pipe 23
 - 2.6 Miscellaneous Items 24
- Chapter 3.0 IGV End Assembly** **27**
 - 3.1 IGV Drive Assembly 28
 - 3.2 IGV Housing Components 29
 - 3.3 IGV Throat 30
 - 3.4 IGV Worm Gear and Motor 31
 - 3.5 Pressure Temperature Sensor Suction 32
 - 3.6 Hermetic Feedthrough IGV 4 Pin 33
- Chapter 4.0 Top Side** **35**
 - 4.1 Top Cover 37
 - 4.2 Mains Input Cover 38
 - 4.3 Soft Start SCR Gate Cable 39
 - 4.4 Cable Harness Soft Start AC/DC 40
 - 4.5 Inverter 43
 - 4.6 Motor Bus Bar Assembly Connectors 44
 - 4.7 Tube Connection to Inverter 45
 - 4.8 Cover Plate Assembly 46
 - 4.9 Hermetic Feedthrough High Power 47
 - 4.10 DC-DC Converter 48
 - 4.11 Mains Input Bracket and Grounding Stud 49
 - 4.12 Terminal Block Assembly 50
 - 4.13 Terminal Block Bus Bars and Fuses 51
 - 4.14 Soft Start Assembly 52



4.15 Soft Start Fuses	55
4.16 Pressure Temperature Sensor Discharge	56
4.17 Silicone-Controlled Rectifiers (SCRs)	57
4.18 Bus Bar	58
4.19 Snubber Capacitors	59
4.20 SCR Heatsink Assembly	60
4.21 Active Cooling Components	63
4.21.1 Heat Exchanger	64
4.21.2 Inlet Pipe	65
4.21.3 Solenoid	66
4.21.4 Cover Plate	67
4.21.5 Blanking Plate	68
Chapter 5.0 Capacitor Side	69
5.1 Capacitor Cover	70
5.2 Bus Bar and Capacitor Assembly	71
Chapter 6.0 Service Side	73
6.1 Service Side Cover	74
6.2 Pulse Width Modulation (PWM) Module	75
6.3 Bearing Motor Compressor Control (BMCC) Module	76
6.4 Serial Driver	77
6.5 Rear/ Front Bearing Sensor Cable Harness	78
6.6 Backplane Assembly	79
6.7 DC Supply Cable Harness	80
6.8 Motor Drive (Inverter to Backplane) Cable Harness	81
6.9 Service Side Beneath Backplane	82
6.10 Compressor Cooling Cable and Coil Assembly	83
6.11 6-Pin Hermetic Feedthrough	85
6.12 Cavity Temperature Sensor/Motor Rotor	86
6.13 4-Pin Hermetic Feedthrough	87
6.14 9-Pin Hermetic Feedthrough	88
6.15 Cooling Valves Assembly	89
6.15.1 Cooling Valves Assembly	89
6.15.2 Solenoid Plunger and Harness Field Upgrade Kit	91
6.15.3 Orifice Body	92
6.15.4 Plunger Assembly	95
6.16 Pressure Regulating Valve	97

Appendix A Test Equipment	99
A.1 DC Bus Test Harness	99
A.2 Compact Inverter Tester	99
Appendix B Accessory Kits	101
B.1 I/O Board Assembly	101
B.2 Compressor Interface Cable	102
B.3 Rubber Mounts	103
B.4 End Cap Insulation	104
B.5 EMI/EMC Filters	105
B.6 Line Reactors	107
B.7 Flanges	109
Appendix C TurbocorCloud® Kits	119
C.1 TurbocorCloud Gateway	119
C.2 SIM Card	120
C.3 Antenna	121
Appendix D Resonator	123
Appendix E Obsoleted Kit Reference	127



THIS PAGE INTENTIONALLY LEFT BLANK

List of Changes

Revision	Date	Page	Description of Change
F.5	8-13-2021	63	Added 575V Capacitor option / Combined TTS350 and TTS400 tables
F.6	1-19-2022	81	Updated Cooling Valve Section, Replaced Cooling Valve assembly PNs
		89	Obsoleted EMI filter 901666
		91	Obsoleted Line Reactors 901453, 901974, and 901975
F.7	5-24-2022	86	Removed the Portable Training Simulator
G	1-17-2023	All Pages	Added TGS380 and TTS450 compressor references throughout this manual as required Reformatted tables to clarify the compressor models that each kit APPLIES TO
G.1	1-20-2023	23	Corrected part number for P/T Discharge sensor
H	5-11-2023	58	Added new SCR Cooling Manifold (100309-15) description and image
H		Appendix B	Added new Compressor Interface Cable kit 100058-5
			Moved all Interface Cable kits to Appendix B
H		Appendix B	Moved I/O Board Assembly to Appendix B
H		48	Added new DC-DC Fuse kit 100084
H		62	Added new Capacitor Membrane kit 100122
H		23/54	Updated P/T sensor from P/N 100037-1 to 100037-2
J	3-11-2024	57	Corrected Snubber Capacitor table
J		29	Added IGV Ball and Glass kits (100137 and 100138)
J		25	Added refrigerant label kits (199K0002 & 199K0003)
J		23, 32, & 54	Added new P/T Sensor replacement O-ring kit 199K0015
J		91	Changed Rubber Mount torque value to 14Nm instead of 27
J		104	Changed flange kit 100450-1 description to 1-3/8. Was incorrectly labeled as 1-5/8
J		26	Added new Compressor Packaging kits 199K0000 and 199K0001
J		89	Added new dual RS485 I/O Board kit 100410
J		20	Obsoleted Cooling fitting and strainer 100215
J		71	Added new Backplane Assy kit 100021-2 and updated image
J		105	Obsoleted Backplane Assembly kit 100021-1
K	9-5-2024	59	Added SCR Cooling Manifold kit 199K0024
K		74	Added O-ring kits 199K0030 and 199K0031
K		75	Added Cooling Cable and Coil Assy kit 199K0026
K		81	Added Cooling Valve kit 199K0029
K		82	Added Solenoid Plunger Field Upgrade kit 199K0025
K		83	Added Orifice kit 199K0027
K		84	Added new kit 199K0030 in table at bottom of page
K		85	Added new Plunger Assembly kit 199K0028
K		Appendix D	Obsoleted kits 100309-9, 100242, and 100052-2
K.1	4-15-2025	Appendix C	Added Resonator kits



Revision	Date	Page	Description of Change
K.1			Obsoleted SCR Cooling Manifold kit 100309-15
K.2	6-4-2025	13	Updated Type Code to include the new No I/O Board and no cable option
K.2		105	Added TurbocorCloud® kits
K.2		56	Updated Snubber Kits - two new kit numbers added
K.3	11-18-2025		Added new Active Cooling kits
K.3		87	Added Orifice kits 199K0083 and 199K0084 Reorganized Cooling Valves Assembly section
K.4	1-29-2026	60	Updated the part number for the Snubber Capacitor requirement in Note 2.
L	5-15-2026		Added TTS650 and TGS510 compressors to existing kit applications
L		20	New Extended Cooling Sleeve kit- 100209
L		28, 29, & 30	Added TTS650 and TGS510 compressor IGV kits: 199K0020, 199K0021, 199K0023
L		48	Added new mainsplate and ground stud kits: 199K0040, 199K0041, 199K0043, & 199K0093
L		58	Added new Snubber Capacitor kit
L		115	New Flange kit for TTS650/TGS510 compressors - 199K0022
L			Obsoleted Snubber Capacitor Kit 100417-2

Proprietary Notice

Copyright, Limitations of Liability and Revision Rights.

This page contains proprietary information to Danfoss LLC. This publication is protected under the Copyright laws of the United States of America (USA) and most other countries. This work is owned by Danfoss LLC, and was published as of the most recent revision of this publication, as indicated on the Title page of this document. This document is for the use Danfoss LLC customers and prospective customers only. Any use beyond that is prohibited.

Tests have demonstrated that equipment produced according to the guidelines provided in this manual will function properly, however Danfoss LLC cannot guarantee the equipment to work in every physical, hardware or software environment.

The guidelines provided in this manual are provided "AS-IS" without any warranty of any kind, either express or implied, including, without limitation, any implied warranties of condition, uninterrupted use, merchantability, fitness for a particular purpose.

In no event shall Danfoss LLC be liable for direct, indirect, special, incidental or consequential damages arising out of the manufacture, use, or the inability to manufacture or use information contained in this manual, even if advised of the possibility of such damages. In particular, Danfoss LLC is not responsible for any costs, including but not limited to those incurred as a result of lost profits or revenue, loss of damage or equipment, loss of computer programs, loss of data, the costs to substitute these, or any claims by third parties. In any event, the total aggregate liability for all damages of any kind and type (regardless of whether based in contract or tort) of Danfoss LLC, shall not exceed the purchase price of this product.

Danfoss LLC reserves the right to revise the publication at any time and to make changes to its contents without prior notice or any obligation to notify former or present users of such revisions or changes.

Danfoss LLC
1769 East Paul Dirac Drive
Tallahassee, Florida 32310
USA
Phone 1-850-504-4800
Fax 1-850-575-2126
<http://turbocor.danfoss.com>

Encounter an error or see an opportunity for improvements while reading this manual? Email us at turbocor.contact@danfoss.com with a brief description.

* Subject to change without notice.

* Danfoss Turbocor's commitment to excellence ensures continuous product improvements.



THIS PAGE INTENTIONALLY LEFT BLANK

Chapter 1.0 Introduction

1.1 Organization

The TT Series Spare Parts Selection Guide is organized in a top-down manner. Sections include External Components, Top Side, Discharge Side, and Service Side. Spare part kits are differentiated using compressor major revision and part number, which can be found on your compressor's name plate. Refer to the product nomenclature on the following page to determine which major revision your compressor falls under. Knowing the major revision, part number, voltage, and electronics type of your compressor are essential to using this document effectively.

1.2 PDF Navigation

This document contains PDF hyperlinks for easy navigation. Clicking on items in the table of contents, or any blue hyperlink text will take you to the page it references.

1.3 Nomenclature

As of May 6, 2019, the product nomenclature changed. The following two illustrations provide examples of the two different formats. Additionally, the "Series" indicators have an additional character in order to differentiate the standard compressors from high-lift compressors. Unless the compressor is a high-lift design, an "S" will be added (e.g., TTS350). A high lift compressor will have an "H" in the Series designation (e.g., TTH375).



Figure 1-1 Conversion from Old Code to New Code

Conversion From Old Code to New Code

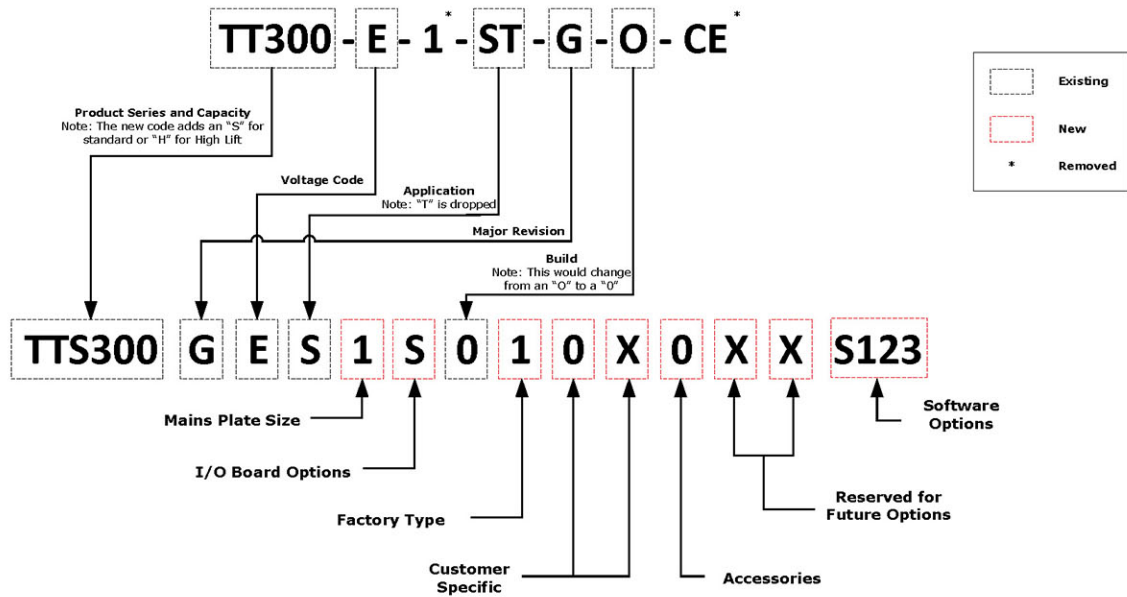

Type Code Definition

Product Series and Capacity

TTS300: TT Series 300 Aero Config
 TTS350: TT Series 350 Aero Config
 TTS400: TT Series 400 Aero Config
 TTS500: TT Series 500 Aero Config
 TTS700: TT Series 700 Aero Config
 TGS230: TG Series 230 Aero Config
 TGS310: TG Series 310 Aero Config
 TGS390: TG Series 390 Aero Config
 TGS520: TG Series 520 Aero Config
 TTH375: TT High Lift Series 375 Aero Config
 TGH285: TG High Lift Series 285 Aero Config

Major Revision

E: Major Revision E
 F: Major Revision F
 G: Major Revision G

Voltage Code

E: 380V/50Hz
 D: 380V/60Hz
 H: 400V/50Hz
 J: 400V/60Hz
 G: 460V/60Hz
 F: 575V/60Hz

Application

S: Standard Application
 M: Medium Temperature Application
 J: Standard Temp KHK Listed
 K: Medium Temp KHK Listed

Mains Plate Size

1: Mains Plate 2.00"
 2: Mains Plate 2.48"
 3: Mains Plate 3.00"
 4: Mains Plate 3.50"

I/O Board Option

S: I/O Board included with 5m cable
 M: No I/O Board, 5m cable Included

Build

0: New Compressor
 C: Rebuilt Certified Compressor

Factory Type

1: TLH Factory (CE Rated)
 2: HYN Factory (CH Rated)
 3: TLH Factory (NC Rated)

Customer Specific Configuration

0: Gen Covers/Plate, EN/FR/CH

Customer Engraved Nameplate

X: No CPN (Standard)
 Y: CPN on Nameplate

Accessories Configuration

0: No accessories

Future Option

X: Reserved
 X: Reserved

Software
 S123: Software Revision



Figure 1-2 TT and TG Product Nomenclature After May 6, 2019

Turboacor TT/TG Series Type Code

	1	2	3	4	5	6	7	8	9	10	11	12	13	14	15	16	17	18	19	20	21	22	
Product Series and Capacity (characters 1-6)	T	T	S	3	0	0	G	E	S	1	S	0	1	0	X	0	X	X	S	1	2	3	
TTS300 : TT Series 300 Aero Config																							
TTS350 : TT Series 350 Aero Config																							
TTS400 : TT Series 400 Aero Config																							
TTS450 : TT Series 450 Aero Config																							
TTS500 : TT Series 500 Aero Config																							
TTS650 : TT Series 650 Aero Config																							
TTS700 : TT Series 700 Aero Config																							
TGS230 : TG Series 230 Aero Config																							
TGS310 : TG Series 310 Aero Config																							
TGS380 : TG Series 380 Aero Config																							
TGS390 : TG Series 390 Aero Config																							
TGS490 : TG Series 490 Aero Config																							
TGS510 : TG Series 510 Aero Config																							
TGS520 : TG Series 520 Aero Config																							
TTH375 : TT High Lift Series 375 Aero Config																							
TGH285 : TG High Lift Series 285 Aero Config																							
Major Revision (character 7)																							
E : Major Revision E																							
F : Major Revision F																							
G : Major Revision G																							
H : Major Revision H																							
J : Major Revision J																							
Voltage Code (character 8)																							
E : 380V/50Hz																							
D : 380V/60Hz																							
H : 400V/50Hz																							
J : 400V/60Hz																							
G : 460V/60Hz																							
F : 575V/60Hz																							
Application (character 9)																							
S : Standard Application																							
M : Medium Temperature Application																							
H : High Temperature Application																							
J : Standard Temp KHK Listed																							
K : Medium Temp KHK Listed																							
A : Active Cooling																							
Mains Plate Size (character 10)																							
1 : Mains Plate 2.00 in																							
2 : Mains Plate 2.48 in																							
3 : Mains Plate 3.00 in																							
4 : Mains Plate 3.50 in																							
I/O Board Option (character 11)																							
S : RS232/RS485 I/O Board included with 5m cable																							
L : RS232/RS485 I/O Board included with 10m cable																							
M : No I/O Board, 5m cable included																							
N : No I/O Board, 10m cable included																							
T : Dual RS485 I/O Board, 5m cable included																							
U : Dual RS485 I/O Board, 10m cable included																							
Z : No I/O Board and no cable included																							
Software (character 19-22)																							
S123 : Software Revision																							
Future Option (character 18)																							
X : Reserved																							
Future Option (character 17)																							
X : Reserved																							
Accessories Configuration (character 16)																							
0 : No accessories																							
Customer Engraved Nameplate (character 15)																							
X : No CPN (Standard)																							
Y : CPN on Nameplate																							
Customer Specific Configuration (character 14)																							
0 : Gen Covers/Plate, EN/FR/CH																							
Factory Type (character 13)																							
1 : TLH Factory (CE Rated)																							
2 : HYN Factory (CH Rated)																							
3 : TLH Factory (ETL Rated Only)																							
4 : NOR Factory (TLH Core)																							
5 : NOR Factory (HYN Core)																							
Build (character 12)																							
0 : New Compressor																							
C : Rebuilt Certified Compressor																							



THIS PAGE INTENTIONALLY LEFT BLANK

Chapter 2.0 External Components

TTS/TGS Model

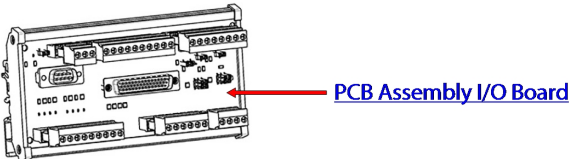
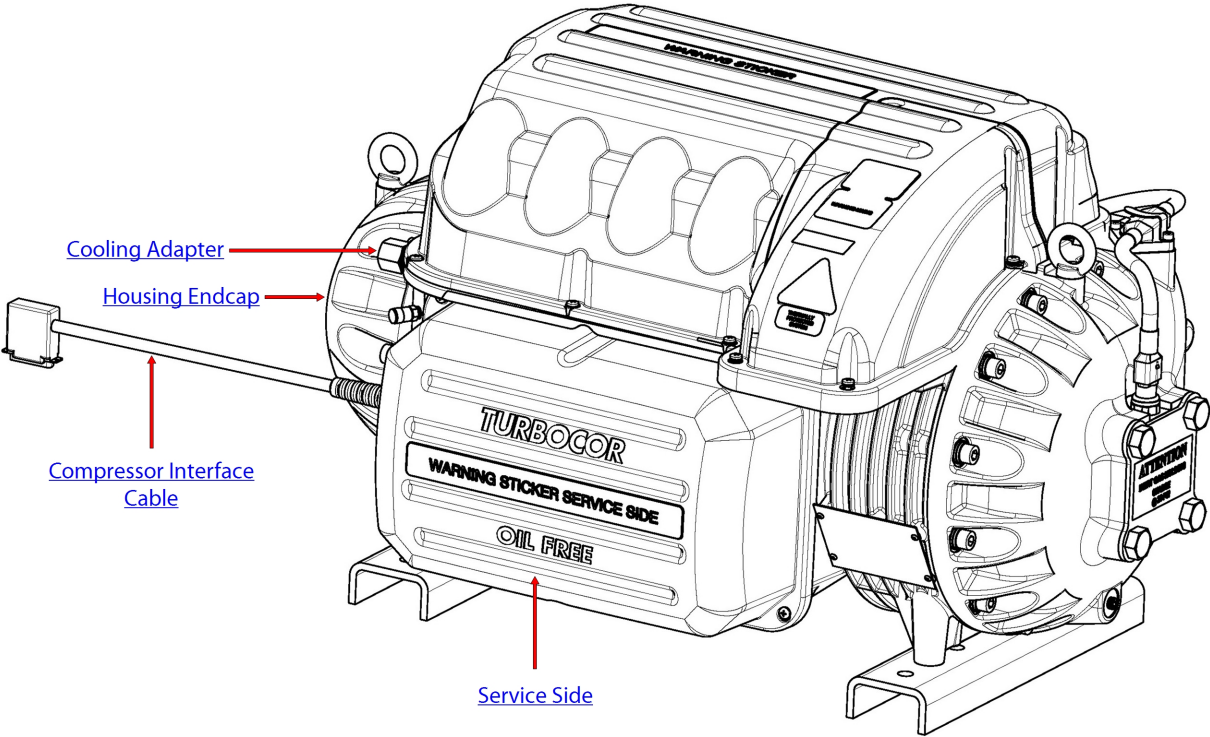

TTS/TGS Model

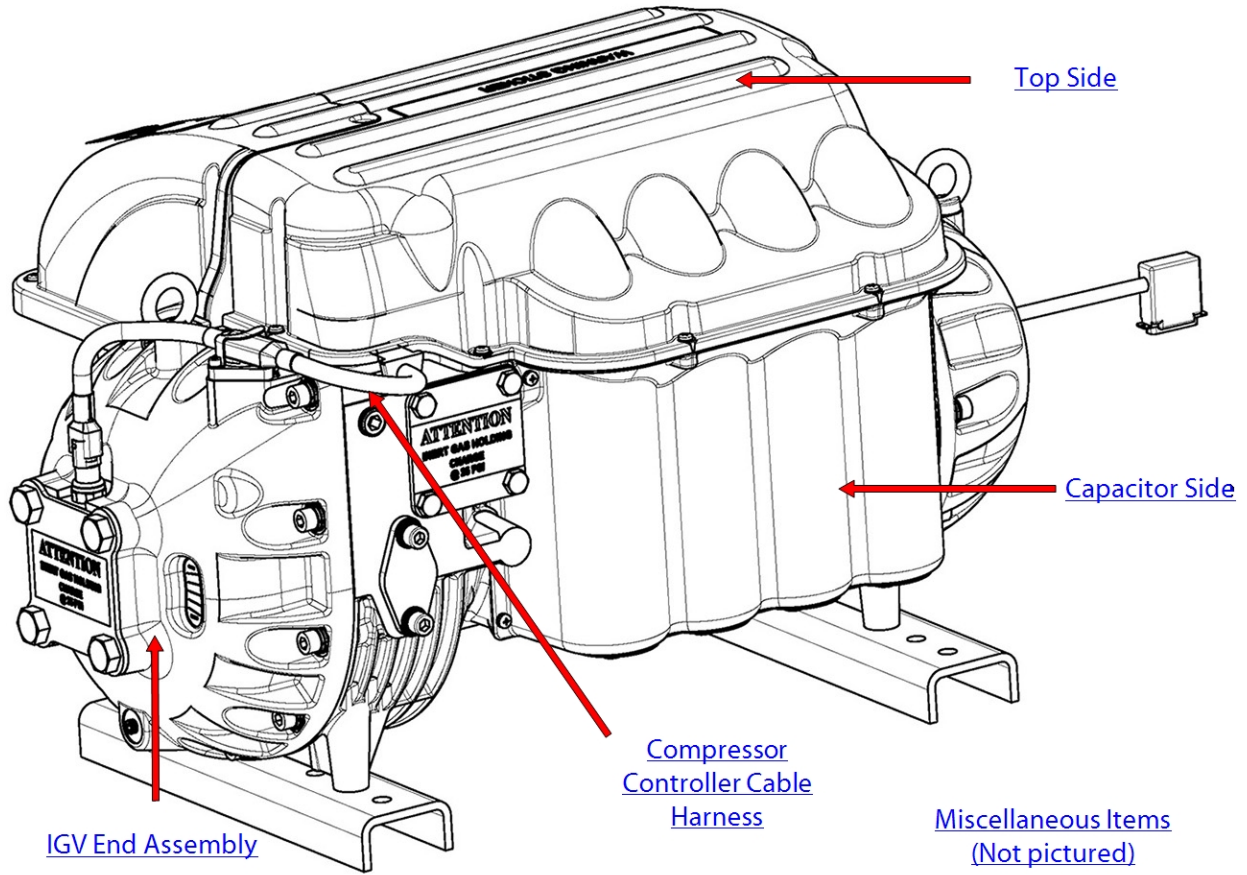

TTH/TGH Model

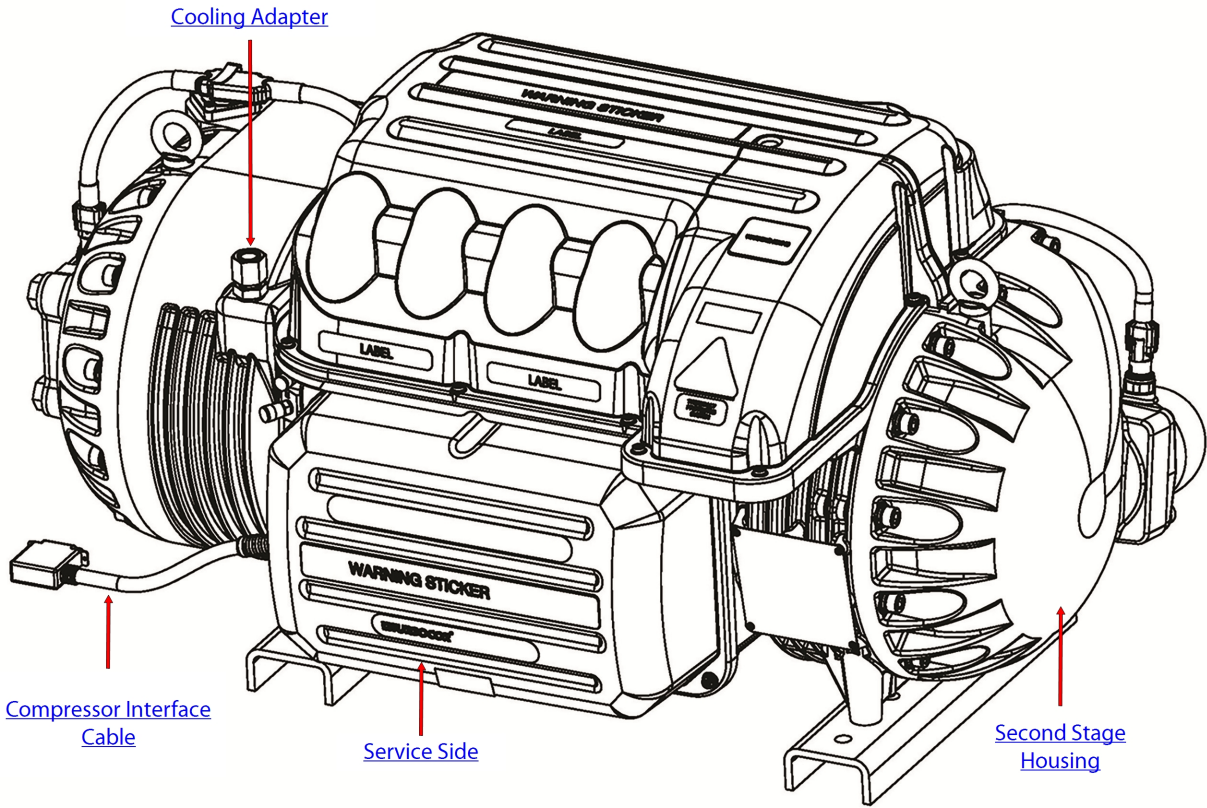

TTH/TGH Model

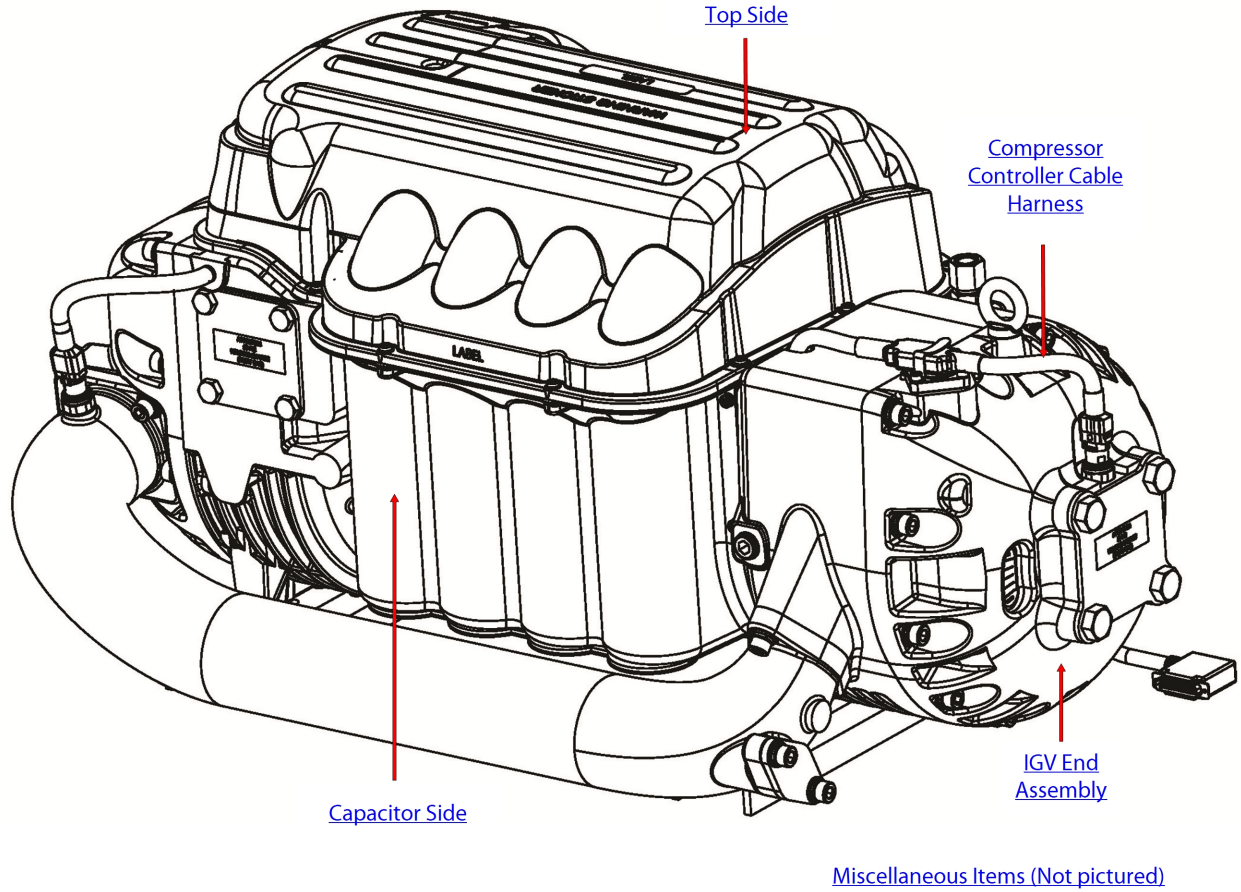

2.1 Compressor Controller Cable Harness

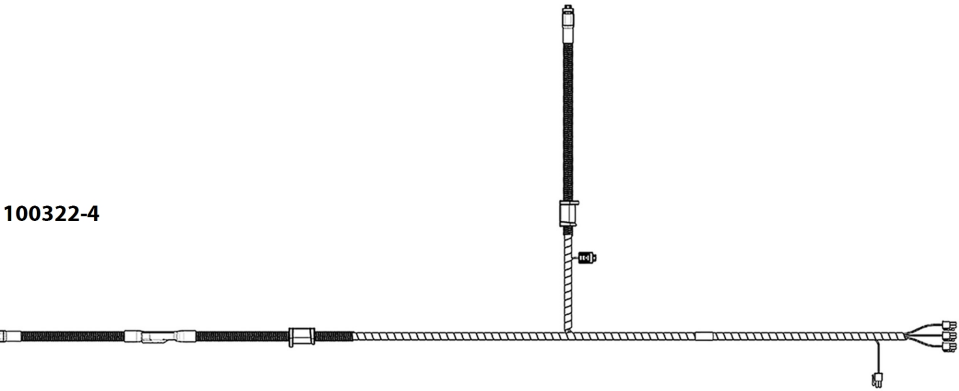
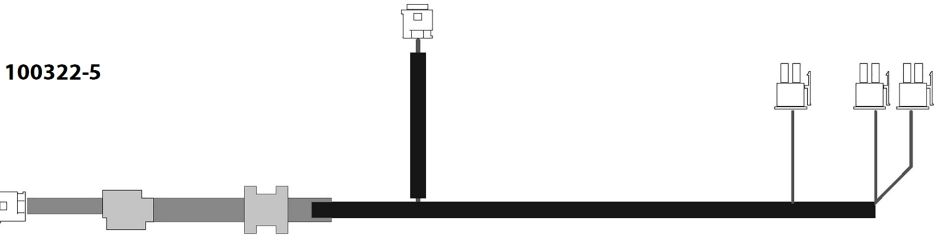

DESCRIPTION	PART NO.	APPLIES TO	MAJOR REV	COMMENT
COMPRESSOR CONTROLLER CABLE HARNESS	100322-5	<ul style="list-style-type: none"> TTS300/TTS350/TTS400/TTS450/TTS500/TTS650 /TTS700 TGS230/TGS310/TGS380/TGS390/TGS490/TGS510 /TGS520 	-N, -P, -A, -C, -D, -E, -F, -G, -H, -J	Cable Only SCR Temperature Sensor connection is no longer available

DESCRIPTION	PART NO.	APPLIES TO	MAJOR REV	COMMENT
COMPRESSOR CONTROLLER CABLE HARNESS	100322-4	<ul style="list-style-type: none"> TTH375/TGH285 	-F, -H, -J	Cable Only

2.2 Cooling Adapter

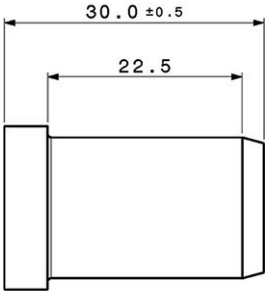
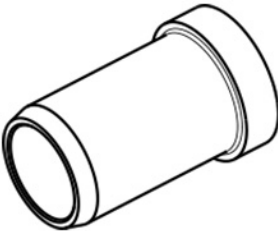
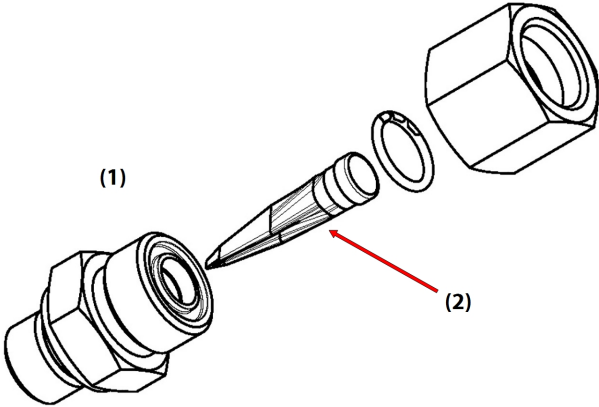

100209

DESCRIPTION	PART NO.	APPLIES TO	MAJOR REV	COMMENT
(1) COOLING ADAPTER W/SCREEN	100169-1	ALL COMPRESSORS	-E, -F, -G, -H, -J	Contains O-rings and strainer
(2) STRAINER FOR COOLING ADAPTER	100186-1	ALL COMPRESSORS	-E, -F, -G, -H, -J	Replaces strainer and one external O-ring
BRAZE SLEEVE, LONG	100209	ALL COMPRESSORS	-E, -F, -G, -H, -J	Includes 10 extended sleeves

2.3 Housing End Cap

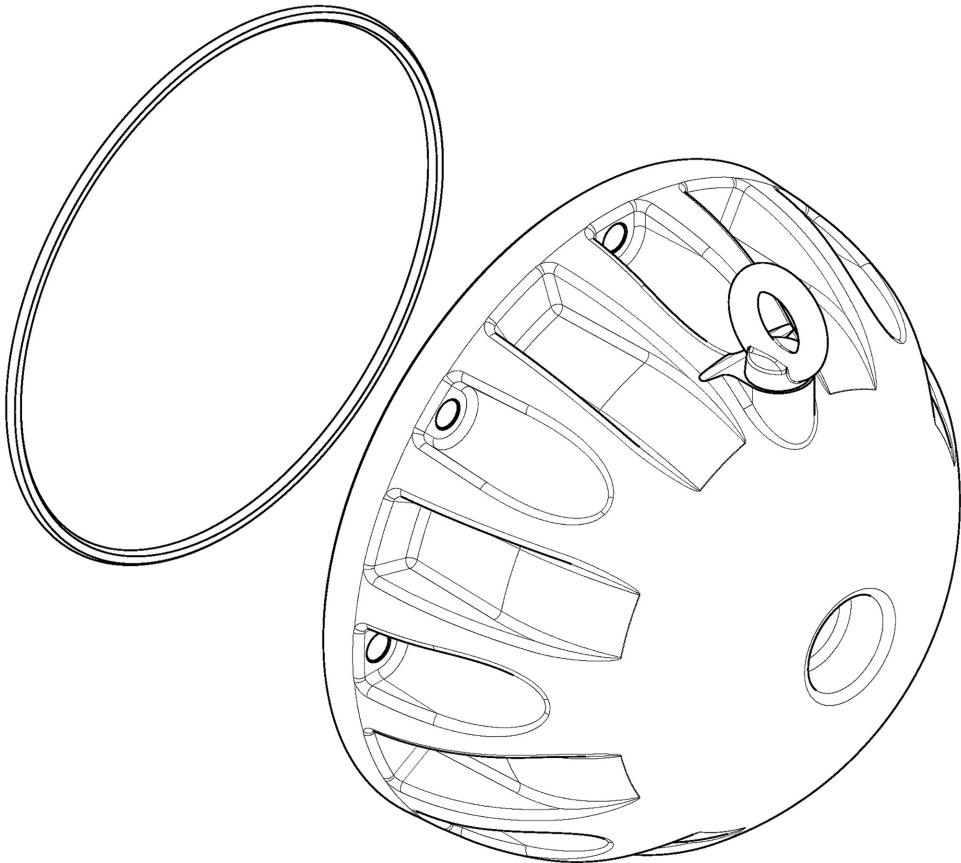

DESCRIPTION	PART NO.	APPLIES TO	MAJOR REV	COMMENT
END CAP ASSY	100324-2	ALL COMPRESSORS Except TTH375/TGH285	ALL	Contains eyebolt, fasteners, and O-ring
O-RING, END CAP	100352	ALL COMPRESSORS Except TTH375/TGH285	ALL	End Cap fasteners and O-ring

2.4 Second Stage Housing

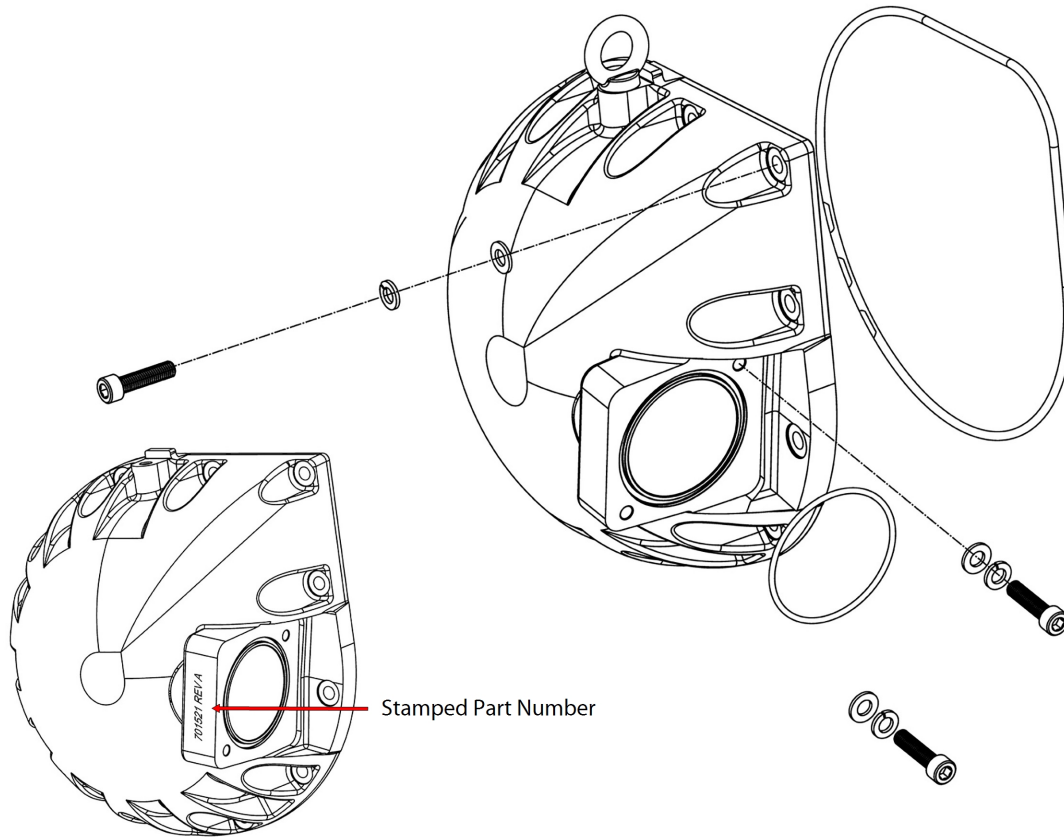

It is important to determine the version of Second Stage Housing that is currently installed on the compressor in order to identify the correct part number. There are two variants of Second Stage Housing and Interstage pipe and they are not interchangeable. Refer to the stamped part number on the Second Stage Housing flange that mates to the Interstage Pipe. When replacing early revision Second Stage Housings, the Interstage Pipe will also need to be replaced.

DESCRIPTION	PART NO.	APPLIES TO	MAJOR REV	COMMENT
SECOND STAGE HOUSING	100706-3	<ul style="list-style-type: none"> TTS375/TGH285 	-F, -H, -J	For Second Stage Housing stamped part number 701521, also order kit 100703-3. For Second Stage Housing stamped part number 741630, no other kit is required. Contains eyebolt, O-rings, and mounting hardware.
O-RINGS, SECOND STAGE HOUSING	100706-2	<ul style="list-style-type: none"> TTH375/TGH285 	-F, -H, -J	Contains O-rings and fasteners for Second Stage Housing, Interstage Pipe, and Economizer

2.5 Interstage Pipe

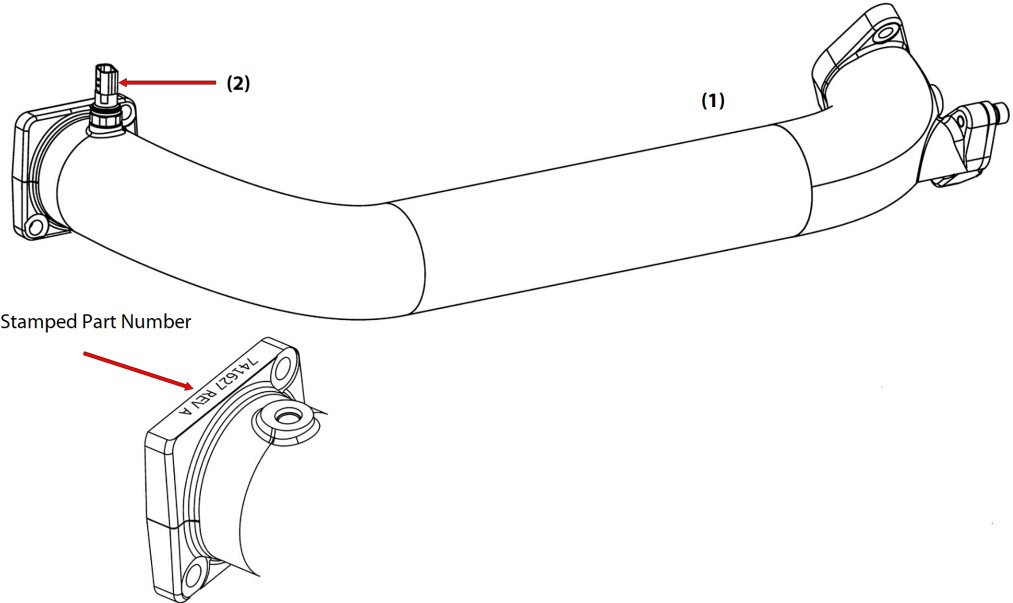

It is important to determine the version of Interstage Pipe that is currently installed on the compressor in order to identify the correct part number. There are two variants of Second Stage Housing and Interstage pipe and they are not interchangeable. Refer to the stamped part number on the Interstage Pipe flange that mates to the Second Stage Housing. When replacing early revision Interstage Pipes, the Second Stage Housing will also need to be replaced.

NOTE

If the part number on the Interstage Pipe is not visible, verify the Second Stage Housing part number. If the Second Stage Housing is part number, 701521, then kits **100703-3** and **100706-3** need to be purchased. If the Second Stage part number is 741630, then purchase kit **100703-3**.

DESCRIPTION	PART NO.	APPLIES TO	MAJOR REV	COMMENT
(1) INTERSTAGE PIPE	100703-3	<ul style="list-style-type: none"> TTH375/TGH285 	-F, -H, -J	For Interstage Pipe stamped part number 741627, also order kit 100706-3. For Interstage Pipe stamped part number 741629, no other kit is required. Contains P/T Sensor, O-rings, and fasteners
(2) PRESSURE/TEMP SENSOR, DISCHARGE	100037-2	<ul style="list-style-type: none"> TTH375/TGH285 	-F, -H, -J	Marked with a red spot and a green spot, contains O-ring
O-RINGS, INTERSTAGE PIPE	100703-2	<ul style="list-style-type: none"> TTH375/TGH285 	-F, -H, -J	Contains O-rings for the Interstage Pipe and Economizer (includes fasteners)
O-RING, P/T SENSORS	199K0015	ALL COMPRESSORS	ALL	Includes four O-rings

2.6 Miscellaneous Items

Port O-rings

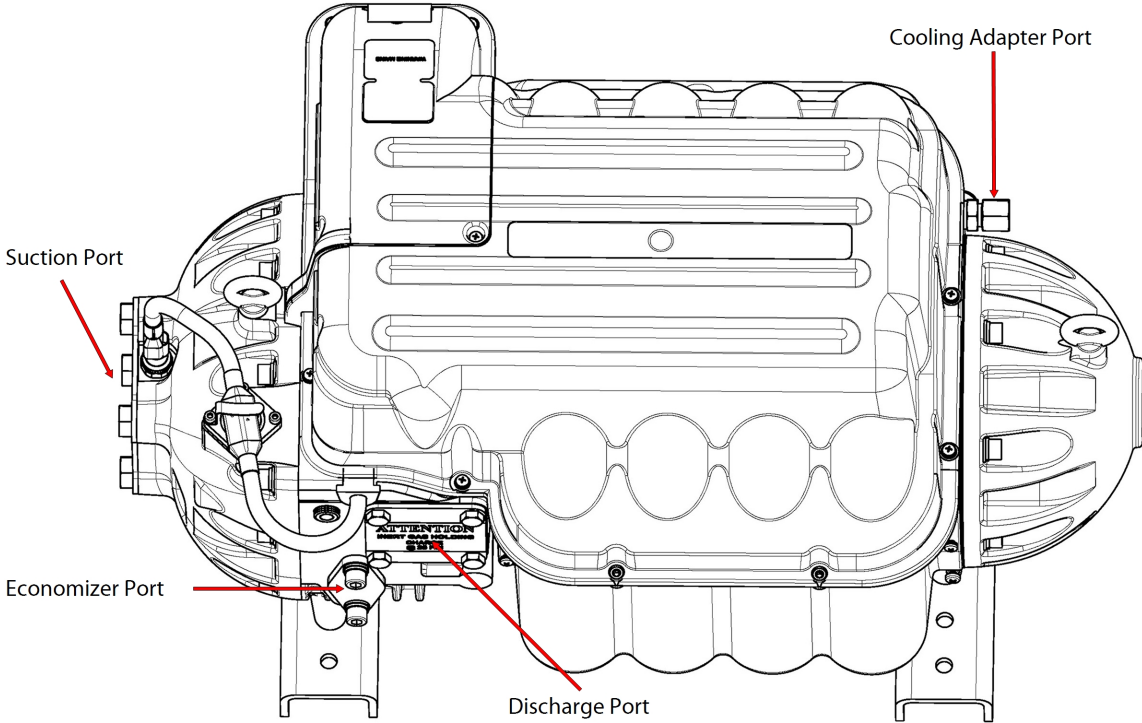

DESCRIPTION	PART NO.	APPLIES TO	MAJOR REV	COMMENT
O-RINGS, PORT CONNECTIONS	100329	ALL COMPRESSORS	ALL	Includes O-rings for Cooling Adapter, Suction, Discharge, and Economizer ports

Miscellaneous Items

Dielectric Grease

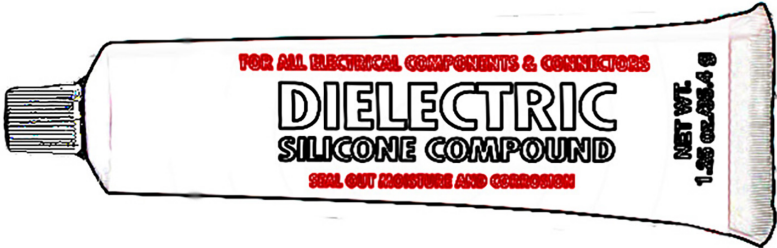

DESCRIPTION	PART NO.	APPLIES TO	MAJOR REV	COMMENT
DIELECTRIC GREASE, 1.25 FL OZ	901982	ALL COMPRESSORS	ALL	1.25 fl. oz. tube of grease only

Refrigerant Labels



DESCRIPTION	PART NO.	APPLIES TO	MAJOR REV	COMMENT
R134a-R513A LABELS	199K0002	<ul style="list-style-type: none"> TTS300/TTS350/TTS400/TTS450/TTS500/TTS650/TTS700 TTH375 	-F, -G, -H, -J	Includes one pair
HFO-R1234ze-R515B LABELS	199K0003	<ul style="list-style-type: none"> TGS230/TGS310/TGS380/TGS390/TGS490/TGS510/TGS520 TGH285 	-F, -G, -H, -J	Includes one pair

Compressor Packaging

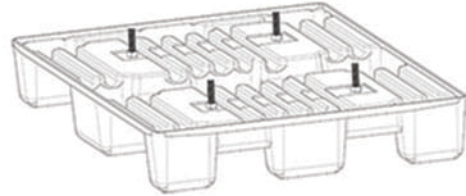
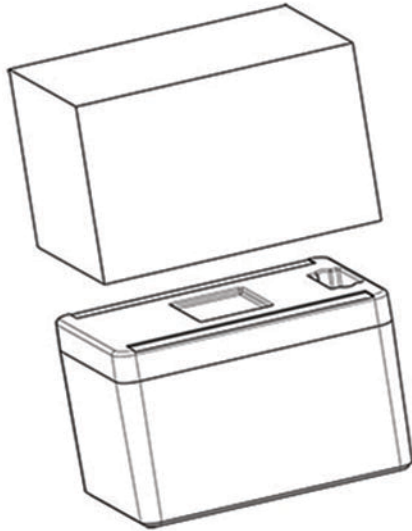

DESCRIPTION	PART NO.	APPLIES TO	MAJOR REV	COMMENT
TT/TG COMPRESSOR PACKAGING	199K0000	ALL TT/TG COMPRESSORS	ALL	Includes box, foam, pallet, and fasteners
TTH/TGH COMPRESSOR PACKAGING	199K0001	ALL TTH/TGH COMPRESSORS	ALL	Includes box, foam, pallet, and fasteners

Chapter 3.0 IGV End Assembly

The spare part kits available for the Inlet Guide Vanes (IGV) Drive assembly are detailed in this section. The IGV Drive Assembly and O-ring kits detailed on the following page replace the entire IGV assembly, including feedthrough, sensor, housing, throat, and motor.

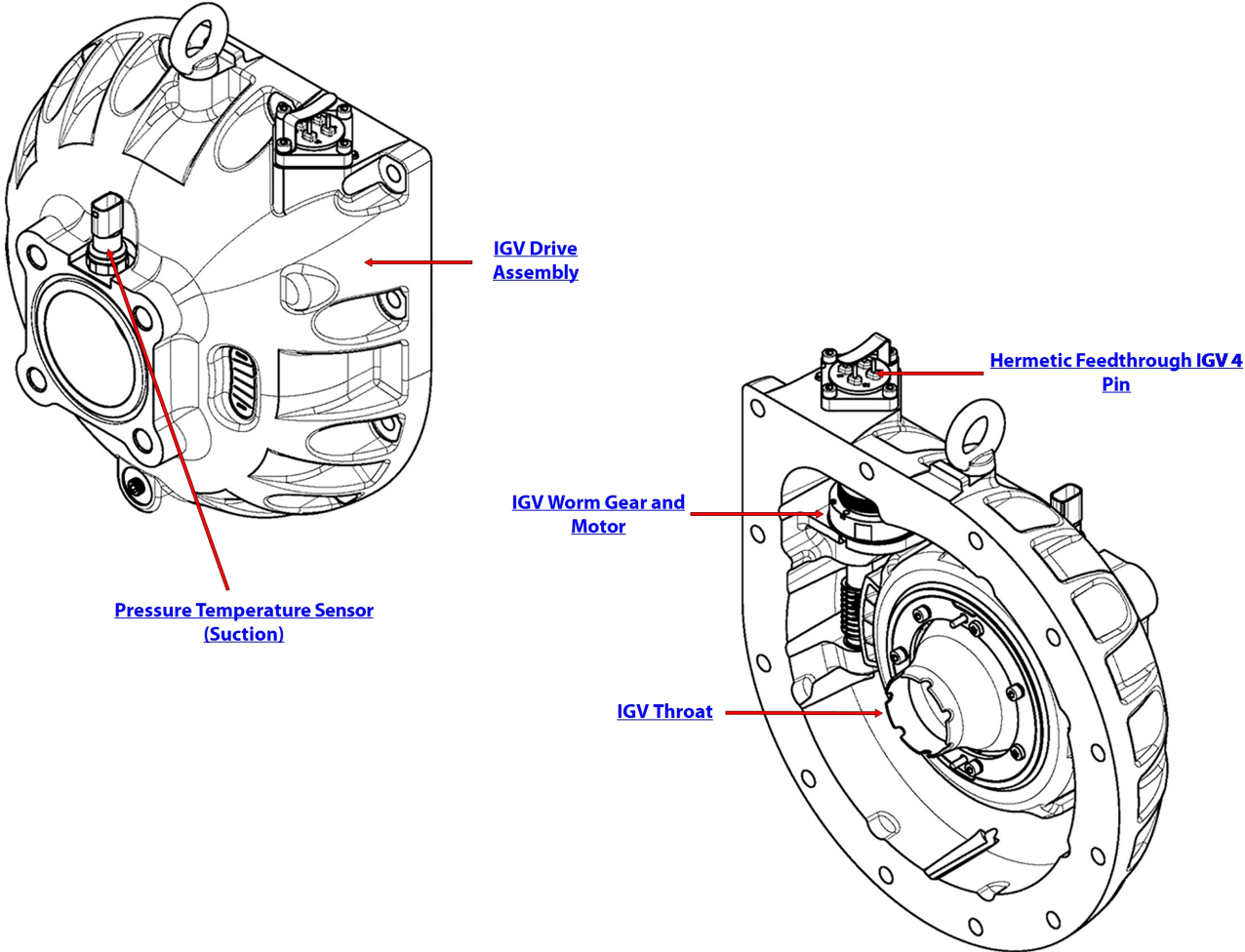

3.1 IGV Drive Assembly

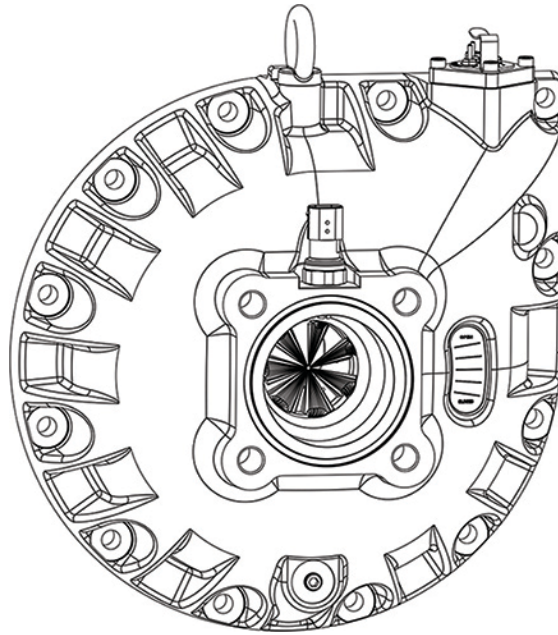

DESCRIPTION	PART NO.	APPLIES TO	MAJOR REV	COMMENT
IGV DRIVE ASSY	100050-16	<ul style="list-style-type: none"> TTS300 TGS230 	-P, -C, -D, -E, -F, -G, -H	Fully assembled IGV Includes O-rings and fasteners
IGV DRIVE ASSY	100050-15	<ul style="list-style-type: none"> TTS350 TGS310 	-A, -E, -F, -H, -J	Fully assembled IGV Includes O-rings and fasteners
IGV DRIVE ASSY	100050-26	<ul style="list-style-type: none"> TTS450 TGS380 	-H	Fully assembled IGV Includes O-rings and fasteners
IGV DRIVE ASSY	100050-17	<ul style="list-style-type: none"> TTS400 TGS390 	-C, -E, -F, -H	Fully assembled IGV Includes O-rings and fasteners
IGV DRIVE ASSY	100050-25	<ul style="list-style-type: none"> TGS490 	-F, -H	Fully assembled IGV Includes O-rings and fasteners
IGV DRIVE ASSY	100050-18	<ul style="list-style-type: none"> TTS500/TTS700 TGS520 	-A, -E, -F, -H	Fully assembled IGV Includes O-rings and fasteners
IGV DRIVE ASSY	199K0021	<ul style="list-style-type: none"> TTS650 TGS510 	-J	Fully assembled IGV Includes O-rings and fasteners
IGV DRIVE ASSY	100050-19	<ul style="list-style-type: none"> TTH375 TGH285 	-F, -H, -J	Fully assembled IGV Includes O-rings and fasteners

3.2 IGV Housing Components

The IGV Housing kits detailed here replace the IGV housing. The plug and indicator ball are pre-installed.

NOTE

The Worm Gear Extractor Tool (100246) is required for the installation of the Worm Gear.

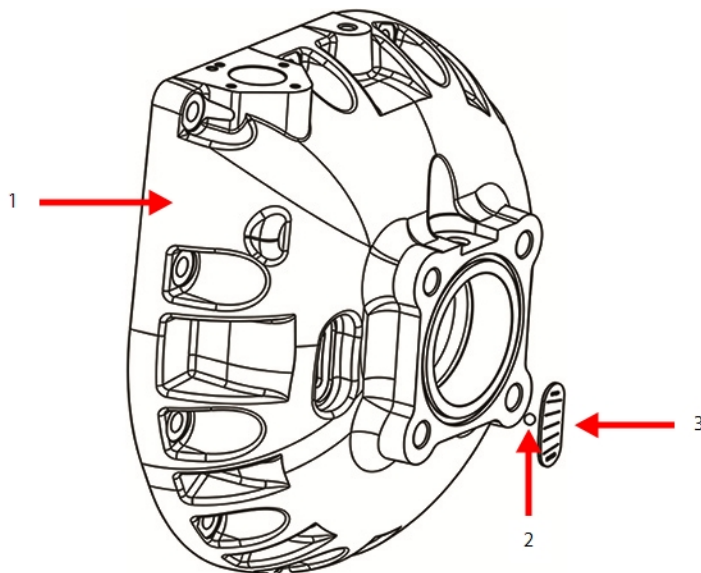

DESCRIPTION	PART NO.	APPLIES TO	MAJOR REV	COMMENT
(1) IGV HOUSING	100223	<ul style="list-style-type: none"> TTS300/TTS350/TTS400/TTS450 TGS230/TGS310/TGS380/TGS390 	ALL	Contains Housing, O-rings, and fasteners Does not include internal components
(1) IGV HOUSING	100229	<ul style="list-style-type: none"> TTS500/TTS700 TGS520/TGS490 	ALL	Contains Housing, O-rings, and fasteners Does not include internal components
(1) IGV HOUSING	199K0023	<ul style="list-style-type: none"> TTS650 TGS510 	ALL	Contains Housing, O-rings, and fasteners Does not include internal components
(1) IGV HOUSING	100223-5	<ul style="list-style-type: none"> TTH375/TGH285 	ALL	Contains Housing, O-rings, and fasteners Does not include internal components
O-RING, IGV ASSY	100051-1	ALL COMPRESSORS	ALL	Includes O-rings and fasteners for Suction, IGV Housing, and IGV Motor Feedthrough
(2) & (3) IGV BALL AND GLASS	100137	ALL COMPRESSORS Except TTH375/TGH285	ALL	Includes IGV Ball and Glass
(2) & (3) IGV BALL AND GLASS	100138	<ul style="list-style-type: none"> TTH375/TGH285 	ALL	Includes IGV Ball and Glass

3.3 IGV Throat

The IGV Throat kits detailed here replace the IGV Throat assembly.

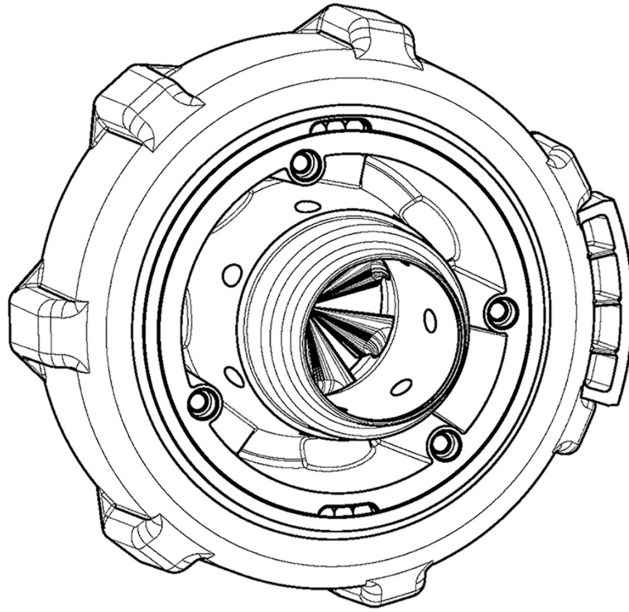

DESCRIPTION	PART NO.	APPLIES TO	MAJOR REV	COMMENT
IGV THROAT	100227	<ul style="list-style-type: none"> TTS300 TGS230 	-P, -C, -D, -E, -F, -G, -H	Contains IGV throat assembly, O-rings, and fasteners
IGV THROAT	100228	<ul style="list-style-type: none"> TTS350 TGS310 	-A, -E, -F, -H, -J	Contains IGV throat assembly, O-rings, and fasteners
IGV THROAT	100392	<ul style="list-style-type: none"> TTS450 TGS380 	-H	Contains IGV throat assembly, O-rings, and fasteners
IGV THROAT	100231	<ul style="list-style-type: none"> TTS400 TGS390 	-C, -E, -F, -H	Contains IGV throat assembly, O-rings, and fasteners
IGV THROAT	100232	<ul style="list-style-type: none"> TTS500/TTS700 TGS520 	-A, -E, -F, -H	Contains IGV throat assembly, O-rings, and fasteners
IGV THROAT	199K0020	<ul style="list-style-type: none"> TTS650 TGS510 	-J	Contains IGV throat assembly, O-rings, and fasteners
IGV THROAT	100261	<ul style="list-style-type: none"> TGS490 	-F, -H, -J	Contains IGV throat assembly, O-rings, and fasteners
IGV THROAT	100704	<ul style="list-style-type: none"> TTH375 TGH285 	-F, -H, -J	Contains IGV throat assembly, O-rings, and fasteners

3.4 IGV Worm Gear and Motor

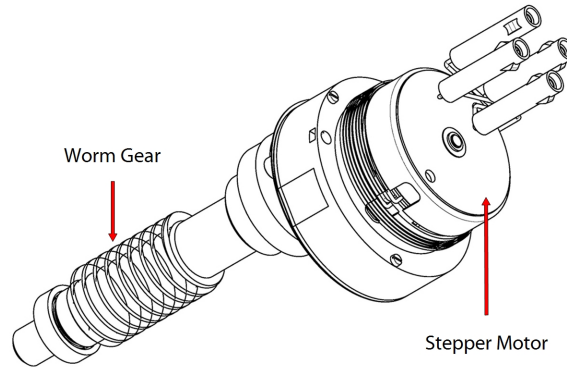

NOTE

The Worm Gear Extractor Tool (100246) is required for removal and installation of the Worm Gear.

DESCRIPTION	PART NO.	APPLIES TO	MAJOR REV	COMMENT
IGV WORM GEAR SHAFT REPAIR	100222	<ul style="list-style-type: none"> TTS300/TTS350/TTS400/TTS450/TTS500/TTS650/TTS700 TGS230/TGS310/TGS380/TGS390/TGS490/TGS510/TGS520 	ALL	Contains Worm Gear, Stepper Motor, Bearings, Collar, Clips, O-rings, and fasteners
IGV WORM GEAR SHAFT REPAIR	100705	<ul style="list-style-type: none"> TTH375/TGH285 	ALL	Contains Worm Gear, Stepper Motor, Bearings, Collar, Clips, O-rings, and fasteners
IGV MOTOR	100035-1	<ul style="list-style-type: none"> TTS300/TTS350/TTS400/TTS450/TTS500/TTS650/TTS700 TGS230/TGS310/TGS380/TGS390/TGS490/TGS510/TGS520 	ALL	Includes Stepper Motor and O-rings
IGV MOTOR	100035-2	<ul style="list-style-type: none"> TTH375/TGH285 	ALL	Includes Stepper Motor, O-rings, and fasteners
O-RING, IGV ASSY	100051-1	ALL COMPRESSORS	ALL	Includes O-rings and fasteners
WORM GEAR EXTRACTOR TOOL	100246	ALL COMPRESSORS	ALL	Worm Gear Extractor tool only

3.5 Pressure Temperature Sensor Suction

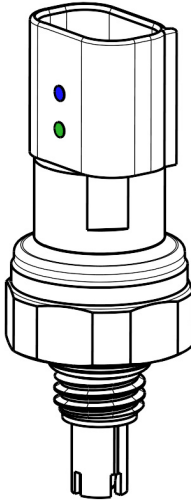

DESCRIPTION	PART NO.	APPLIES TO	MAJOR REV	COMMENT
PRESSURE/TEMP SENSOR, SUCTION	100036-1	ALL COMPRESSORS	ALL	Marked with a blue dot and a green dot Includes O-ring
O-RING, P/T SENSORS	199K0015	ALL COMPRESSORS	ALL	Includes four O-rings

3.6 Hermetic Feedthrough IGV 4 Pin

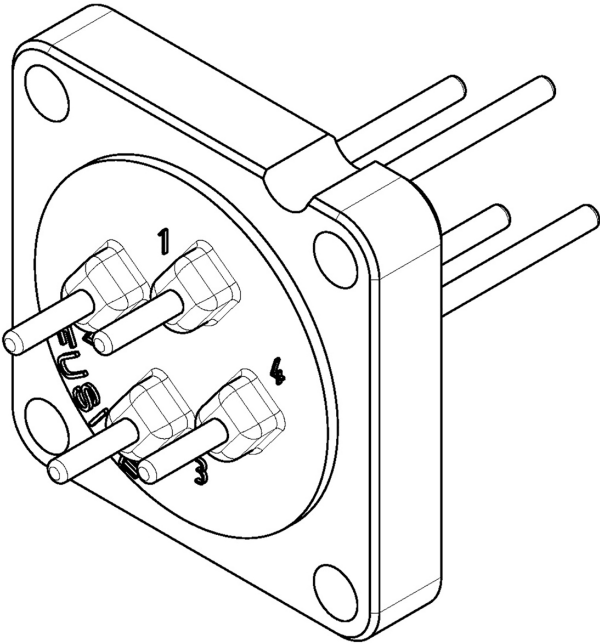

DESCRIPTION	PART NO.	APPLIES TO	MAJOR REV	COMMENT
4 PIN IGV FEEDTHROUGH	100321-1	ALL COMPRESSORS	ALL	Includes O-ring, clamp, and fasteners



THIS PAGE INTENTIONALLY LEFT BLANK

Chapter 4.0 Top Side

This section details the spare part kits available for components underneath the Top Side and Mains Input covers.

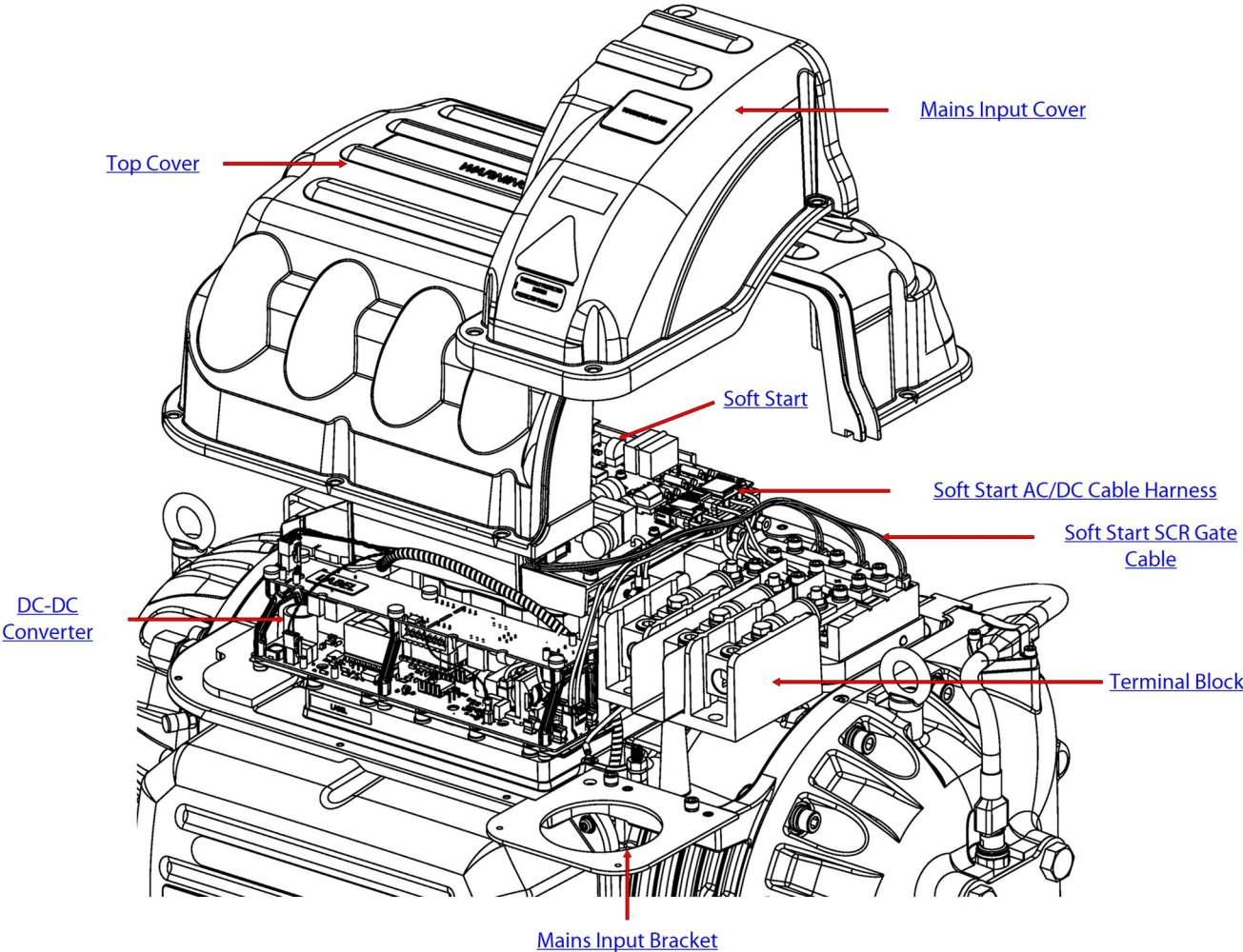

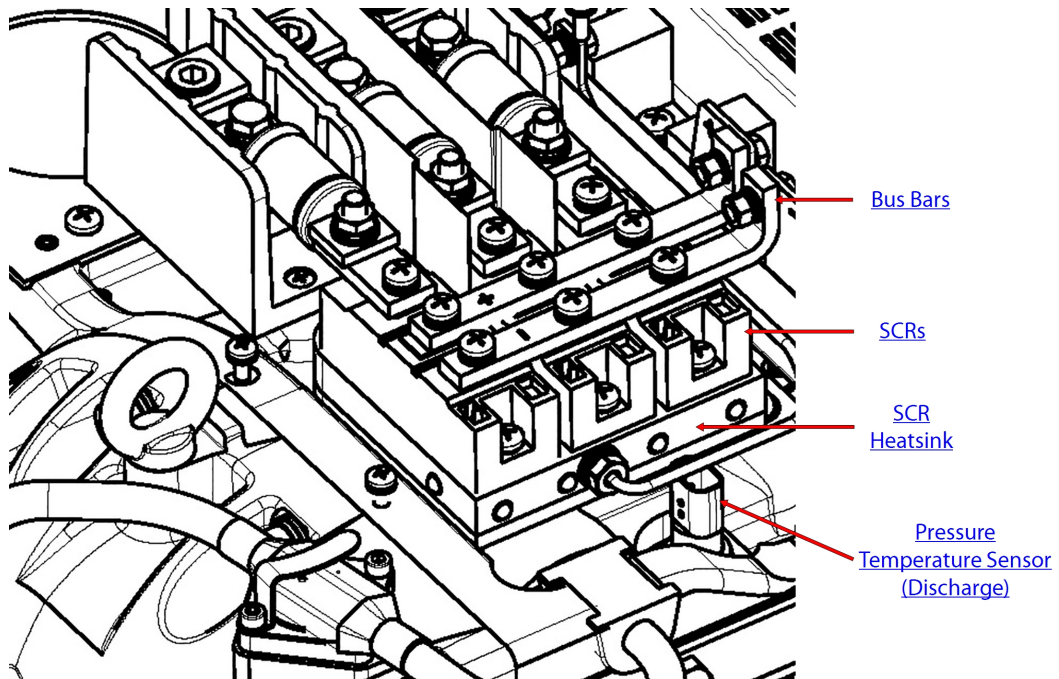
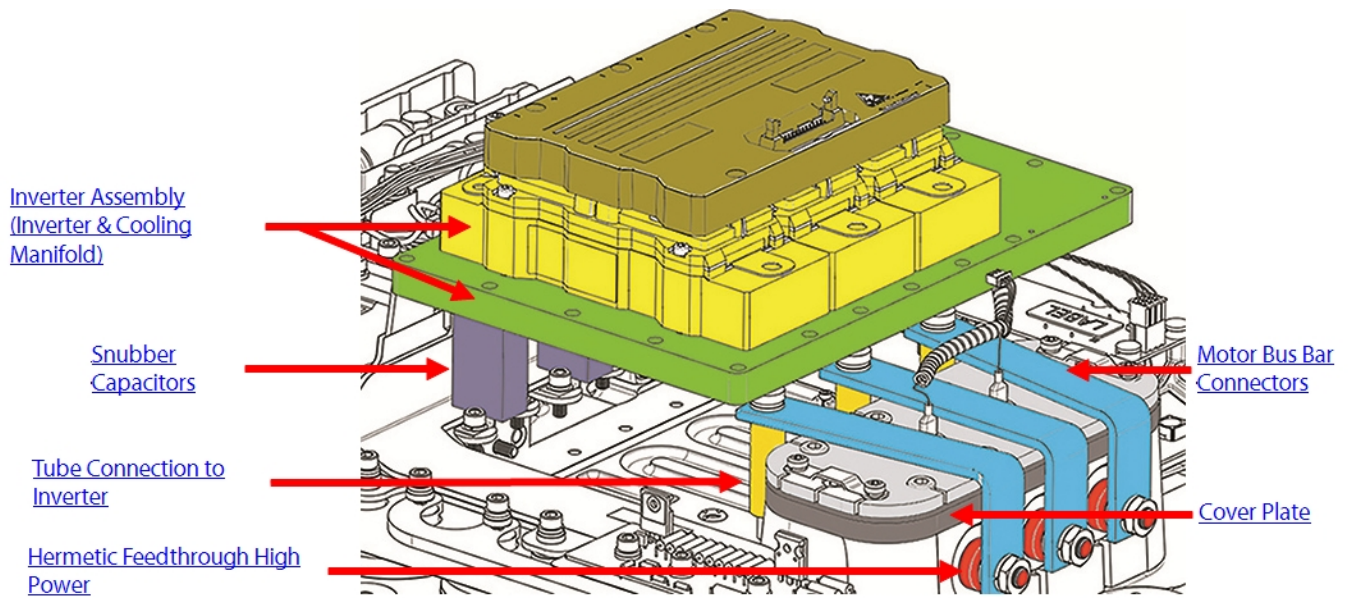

4.1 Top Cover

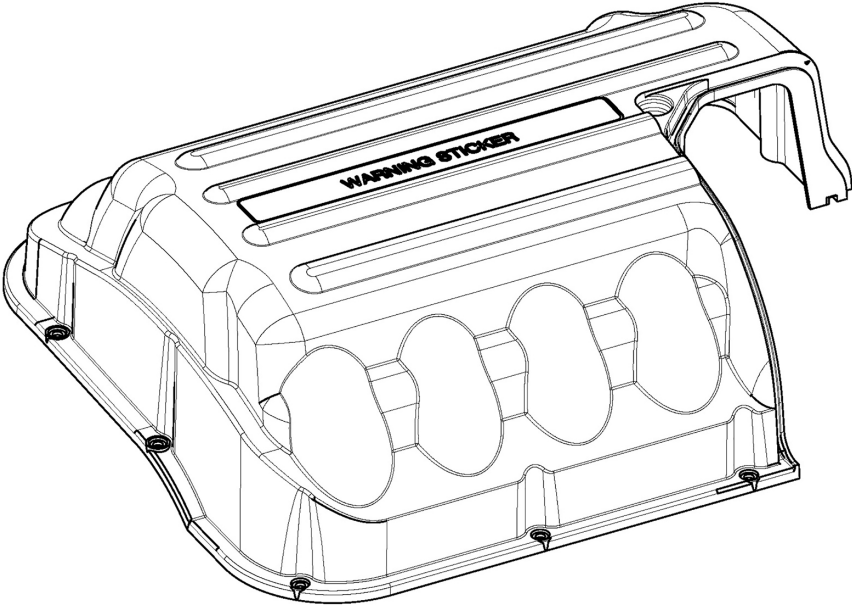

DESCRIPTION	PART NO.	APPLIES TO	MAJOR REV	COMMENT
TOP COVER, BLACK, EN/FR	100054-3	<ul style="list-style-type: none"> TTS300/TTS350/TTS400/TTS450/TTS500/TTS650/TTS700 TTH375 	ALL	Includes fasteners
TOP COVER, GREEN, EN/FR	100054-6	<ul style="list-style-type: none"> TGS230/TGS310/TGS380/TGS390/TGS490/TGS510/TGS520 TGH285 	ALL	Includes fasteners
COVERS SCREW, M5, STAINLESS	100252	ALL COMPRESSORS	ALL	Replaces fasteners for all four covers (24 fasteners)

4.2 Mains Input Cover

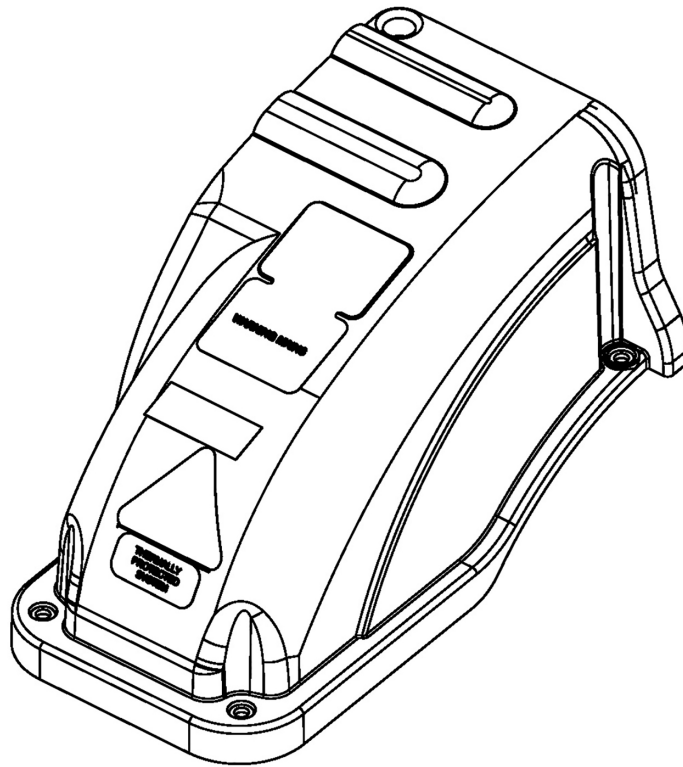

DESCRIPTION	PART NO.	APPLIES TO	MAJOR REV	COMMENT
MAINS INPUT COVER, BLACK	100056-3	<ul style="list-style-type: none"> TTS300/TTS350/TTS400/TTS450/TTS500/TTS650/TTS700 TTH375 	ALL	Includes fasteners
MAINS INPUT COVER, GREEN	100056-6	<ul style="list-style-type: none"> TGS230/TGS310/TGS380/TGS390/TGS490/TGS510/TGS520 TGH285 	ALL	Includes fasteners
COVERS SCREW, M5, STAINLESS	100252	ALL COMPRESSORS	ALL	Replaces fasteners for all four covers (24 fasteners)

4.3 Soft Start SCR Gate Cable

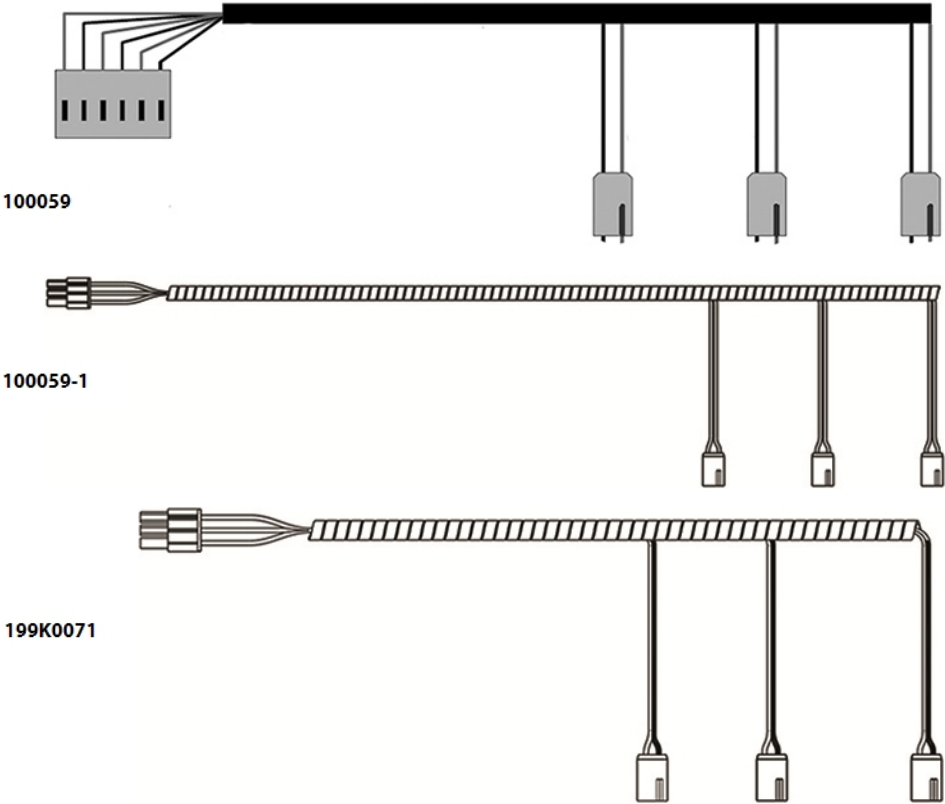

It is important to determine the Soft Start that is currently installed on the compressor. Pre-revision H compressors may contain a Soft Start that has been upgraded to the 200193 version. The different style Soft Starts utilize different SCR Cables. Refer to Section 4.14 Soft Start Assembly on page 52 for proper Soft Start identification.

DESCRIPTION	PART NO.	APPLIES TO	MAJOR REV	COMMENT
CABLE, SOFTSTART SCR GATE	100059	ALL COMPRESSORS	-N, -P, -C, -D, -E, -F, -G	Legacy Soft Starts Includes cable only
CABLE, SOFTSTART SCR GATE	100059-1	ALL COMPRESSORS	-H	200193 Soft Starts Includes cable only
CABLE, SOFTSTART SCR GATE	199K0071	<ul style="list-style-type: none"> TTS350/TTS650 TGS310/TGS510 TTH375/TGH285 	-J	200095 Soft Starts Includes cable only

4.4 Cable Harness Soft Start AC/DC

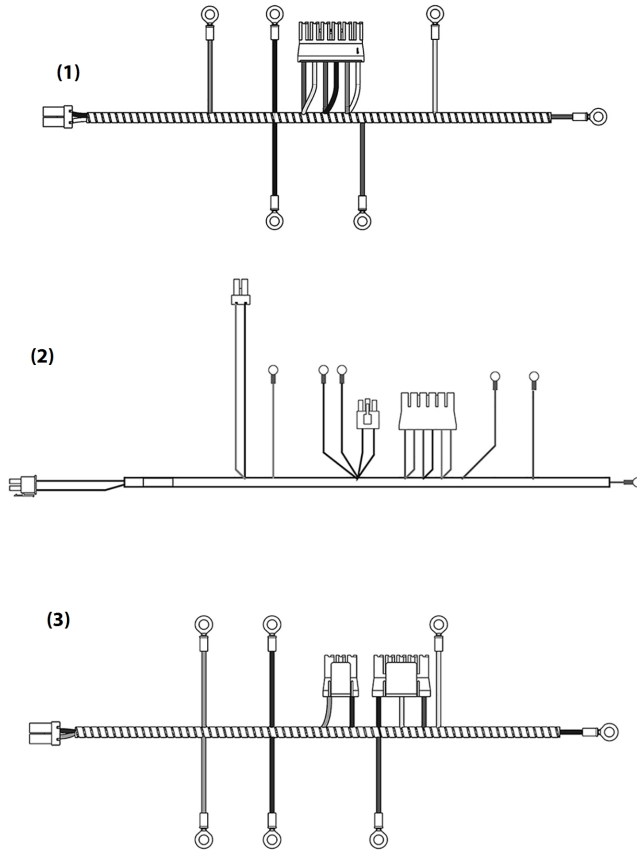

It is important to determine the Soft Start that is currently installed on the compressor, as well as the DC-DC Converter and Bus Bar assembly. Pre-revision H compressors may contain a Soft Start and DC-DC Converter that has been upgraded. Each of these items will impact the required kit. Refer to the Comment section in the tables below to determine the appropriate kit for the existing compressor. Also, refer to Section 4.14 Soft Start Assembly on page 52 for proper Soft Start identification.

DESCRIPTION	PART NO.	APPLIES TO	MAJOR REV	COMMENT
(1 & 2) CABLE, SOFTSTART AC/DC	100380	<ul style="list-style-type: none"> TTS300 TGS230 	-N, -P, -C, -D, -E, -F, -G	<p>Cable Only</p> <p>Includes two cables in order to accommodate either DC-DC style</p>
(3) CABLE, SOFTSTART AC/DC	100380-1	<ul style="list-style-type: none"> TTS300 TGS230 	-H	<p>Cable Only</p> <p>Rev. G compressors can use this cable if they have the Open Frame DC-DC and the 200193 Soft Start installed</p>

Cable Harness Soft Start AC/DC (continued)

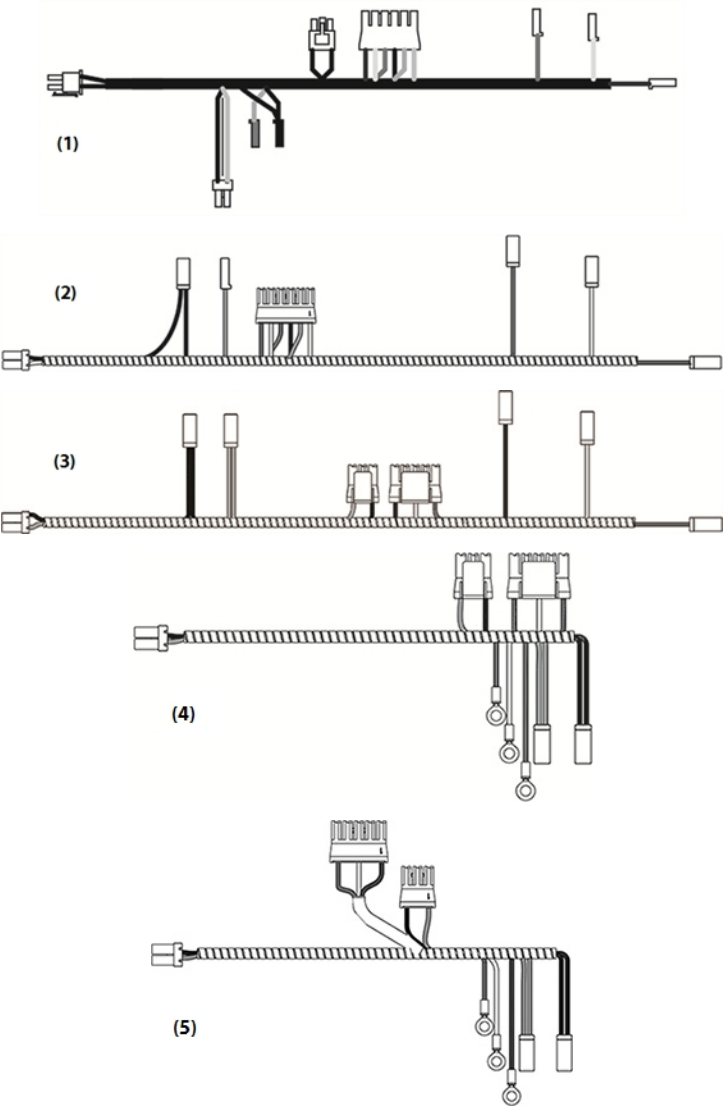

DESCRIPTION	PART NO.	APPLIES TO	MAJOR REV	COMMENT
(1 & 2) CABLE, SOFTSTART AC/DC	100381	<ul style="list-style-type: none"> TTS350/TTS400/TTS450/TTS500/TTS700 TGS310/TGS380/TGS390/TGS490/TGS520 TTH375/TGH285 	-P, -A, -C, -E, -F	Cable Only Includes two cables in order to accommodate either DC-DC style
(3) CABLE, SOFTSTART AC/DC	100381-2	<ul style="list-style-type: none"> TTS350/TTS400/TTS450/TTS500/TTS700 TGS310/TGS380/TGS390/TGS490/TGS520 TTH375/TGH285 	-P, -A, -C, -E, -F	Cable Only For use with the 200193 Soft Start, Open Frame DC-DC, and Curved Bus Bars



DESCRIPTION	PART NO.	APPLIES TO	MAJOR REV	COMMENT
(4) CABLE, SOFTSTART AC/DC	100381-1	<ul style="list-style-type: none">• TTS350/TTS400/TTS450/TTS500/TTS700• TGS310/TGS380/TGS390/TGS490/TGS520• TTH375/TGH285	-H	Cable Only For use with the 200193 Soft Start, Open- Frame DC-DC, small SCRs, and Straight Bus Bars
(5) CABLE, SOFTSTART AC/DC	199K0072	<ul style="list-style-type: none">• TTS350/TTS650• TGS310/TGS510• TTH375/TGH285	-J	Includes cable and fasteners Can be used with Active Cooling models

4.5 Inverter

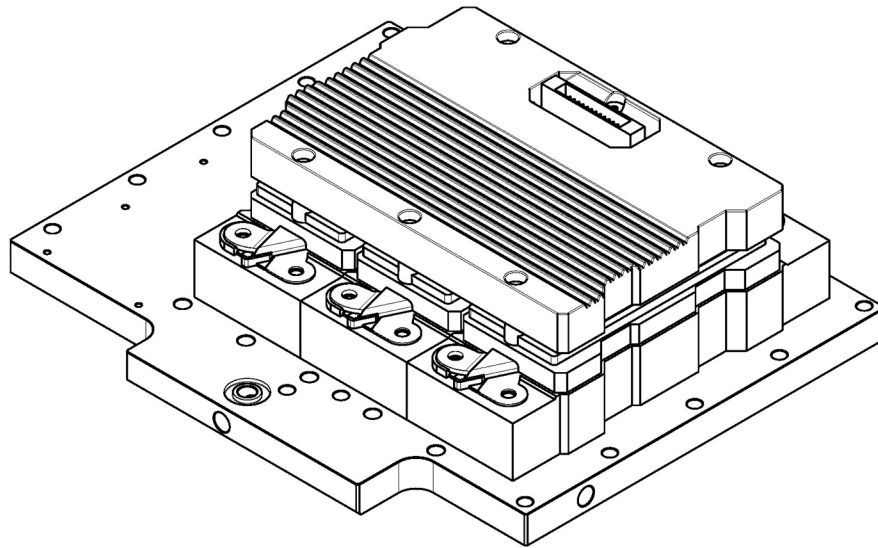

DESCRIPTION	PART NO.	APPLIES TO	MAJOR REV	COMMENT
INVERTER ASSEMBLY CONVERSION (342 to 613)	100521*	<ul style="list-style-type: none"> TTS300 TGS230 	-N, -P, -C, -D, -E, -F	Includes motor bus bars, manifold insulator, fasteners, and O-rings
INVERTER ASSEMBLY, 613	100043-13*	<ul style="list-style-type: none"> TTS300 TGS230 	-G, -H	Includes fasteners and O-rings
INVERTER ASSEMBLY, 613	100043-11	<ul style="list-style-type: none"> TTS350/TTS400/TTS450/TTS500/TTS650/TTS700 TGS310/TGS380/TGS390/TGS490/TGS510/TGS520 TTH375/TGH285 	-P, -A, -C, -E, -F, -H, -J	Includes fasteners and O-rings
O-RINGS, INVERTER ASSY	100310-2	<ul style="list-style-type: none"> TTS300 TGS230 	ALL	Includes Inverter O-rings and fasteners
O-RING, INVERTER ASSY	100310-1	<ul style="list-style-type: none"> TTS350/TTS400/TTS450/TTS500/TGS650/TTS700 TGS310/TGS380/TGS390/TGS490/TGS510/TGS520 TTH375/TGH285 	ALL	Includes Inverter O-rings and fasteners

*Refer to Customer Notification (B-CN-079)

4.6 Motor Bus Bar Assembly Connectors

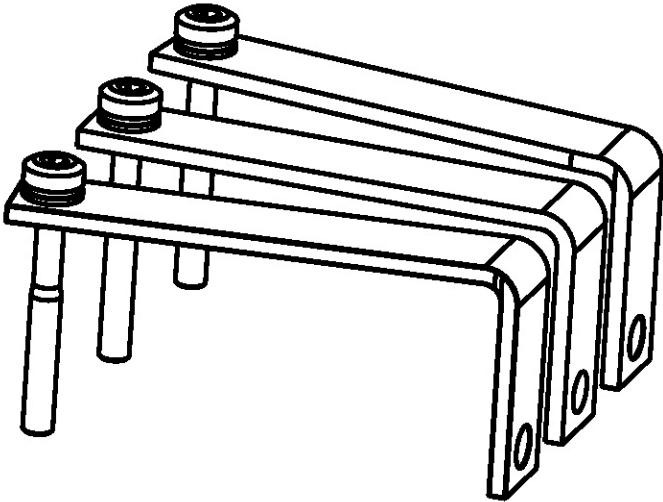

DESCRIPTION	PART NO.	APPLIES TO	MAJOR REV	COMMENT
MOTOR BUS BAR ASSY	100313	<ul style="list-style-type: none"> TTS300 TGS230 	-N, -P, -C, -D, -E, -F	Includes three bus bars and fasteners
MOTOR BUS BAR ASSY	100313-1	<ul style="list-style-type: none"> TTS300*/TTS350/TTS400/TTS450/TTS500/TTS650/TTS700 TGS230*/TGS310/TGS380/TGS390/TGS490/TGS510/TGS520 TTH375/TGH285 	-P, -A, -C, -E, -F, G, -H, -J	Includes three bus bars and fasteners

*Refer to Customer Notification (B-CN-079-EN) - This kit is for TTS300/TGS230 Rev. G and later compressors or when Conversion Kit (100521) has already been applied

4.7 Tube Connection to Inverter

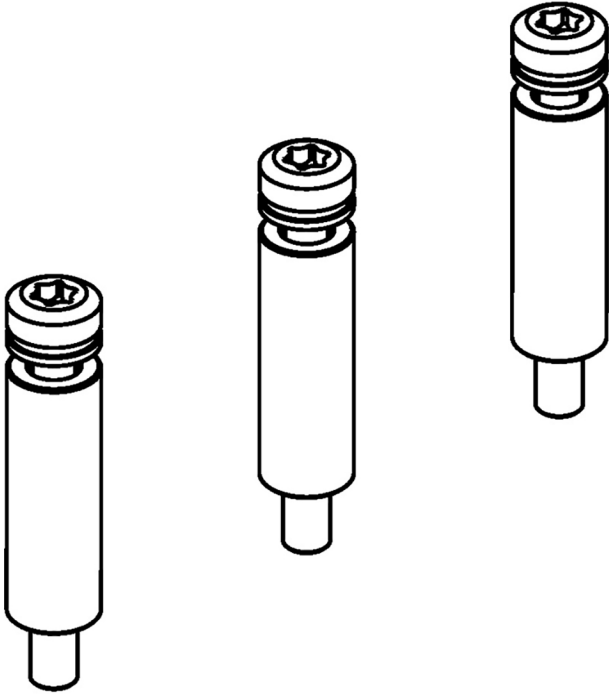

DESCRIPTION	PART NO.	APPLIES TO	MAJOR REV	COMMENT
TUBE CONNECTION TO INVERTER	100311	ALL COMPRESSORS	ALL	Includes three tubes and fasteners

4.8 Cover Plate Assembly

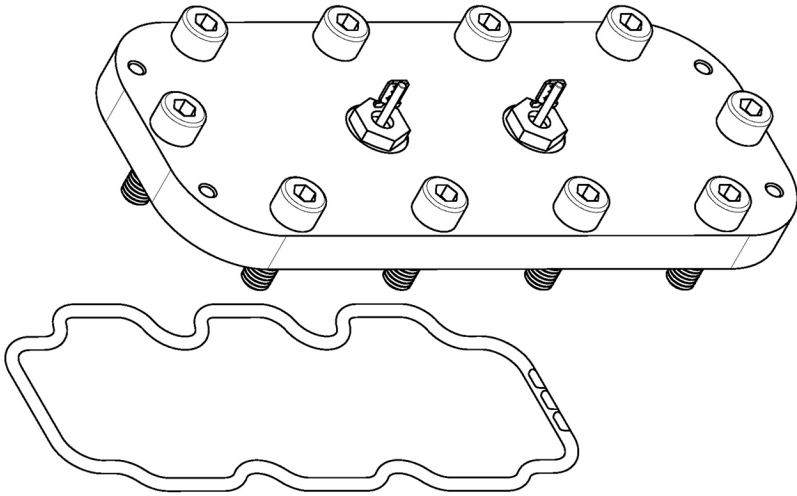

DESCRIPTION	PART NO.	APPLIES TO	MAJOR REV	COMMENT
COVER PLATE ASSY	100314-2	ALL COMPRESSORS (excluding Active Cooling)	-N, -P, -A, -C, -D, -E, -F, -G, -H, -J	Includes O-ring, insulation, and fasteners
HARDWARE-COVER PLATE	100315-1	ALL COMPRESSORS (excluding Active Cooling)	-N, -P, -A, -C, -D, -E, -F, -G, -H, -J	Includes O-ring and fasteners

4.9 Hermetic Feedthrough High Power

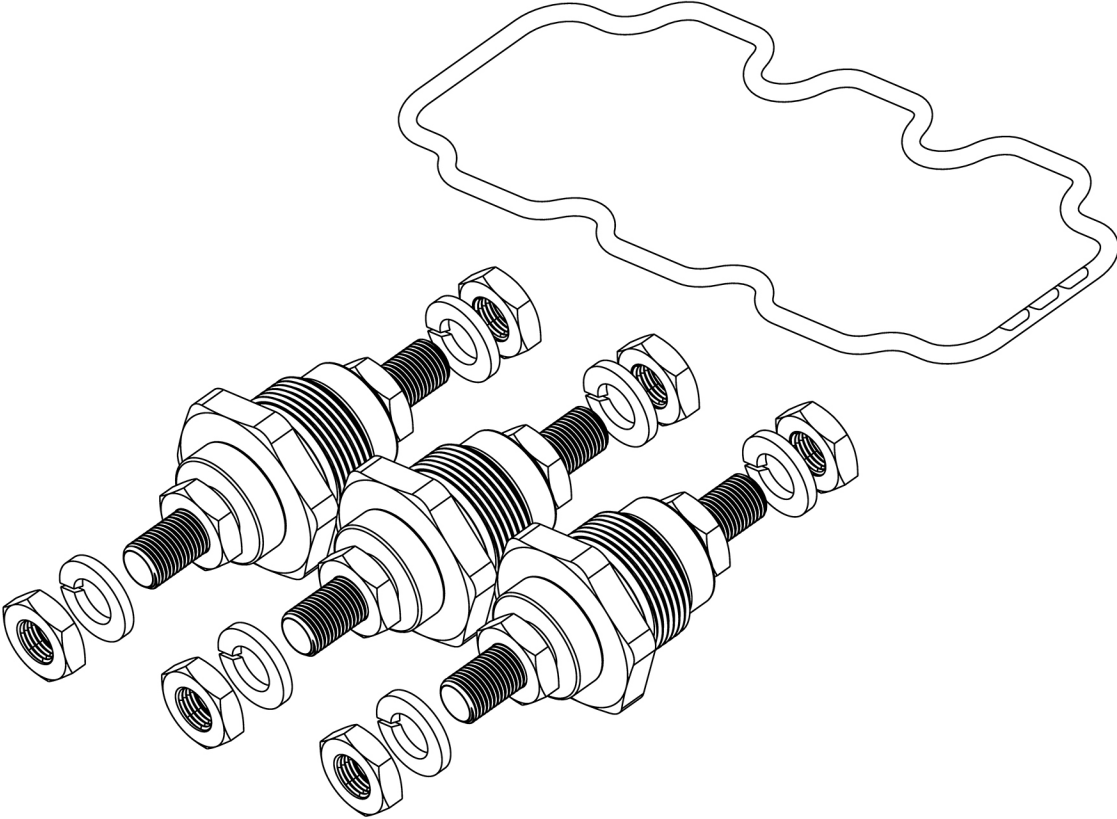

DESCRIPTION	PART NO.	APPLIES TO	MAJOR REV	COMMENT
HIGH-POWER FEEDTHROUGH	100383	ALL COMPRESSORS	ALL	Includes three high power feedthroughs, fasteners, and O-rings
HARDWARE-COVER PLATE	100315-1	ALL COMPRESSORS (excluding Active Cooling)	-N, -P, -A, -C, -D, -E, -F, -G, -H, -J	Custom O-ring (shown) and fasteners

4.10 DC-DC Converter

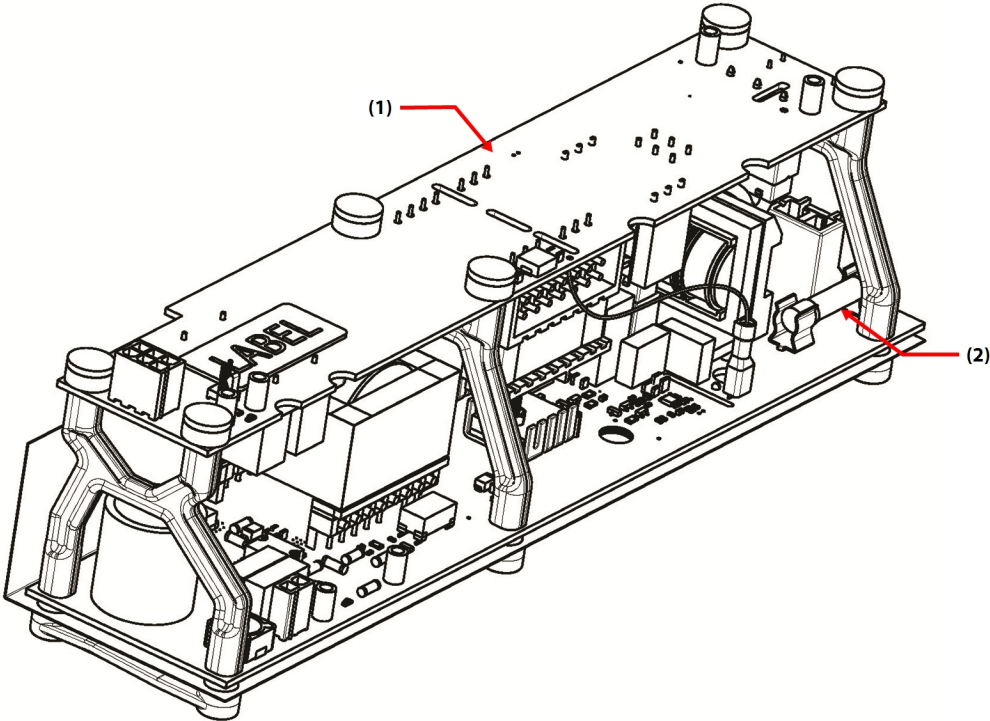

DESCRIPTION	PART NO.	APPLIES TO	MAJOR REV	COMMENT
(1) DC-DC CONVERTER	100379	ALL COMPRESSORS	ALL	Includes fasteners
(2) FUSE, 2A, 1000V	100084	ALL COMPRESSORS	ALL OPEN FRAME DC-DC CONVERTERS	Includes two fuses

4.11 Mains Input Bracket and Grounding Stud

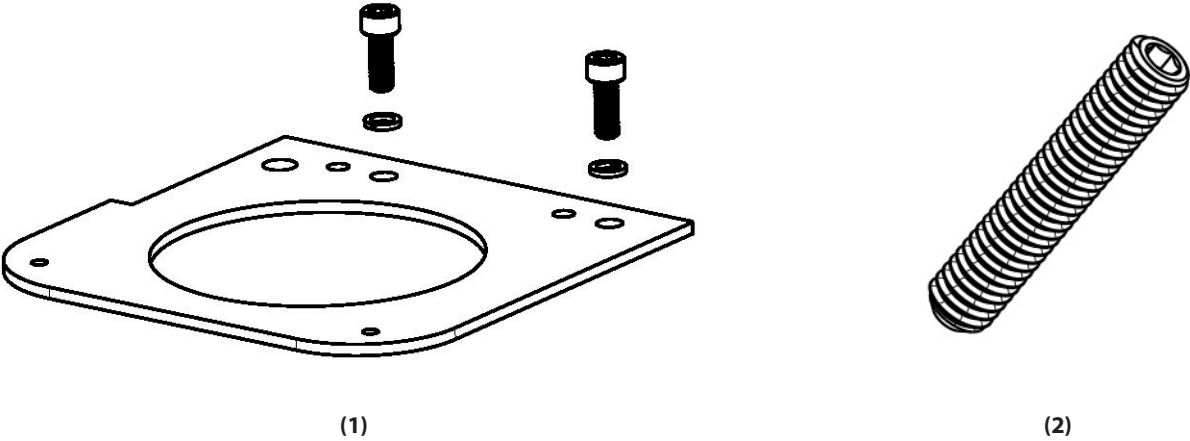

DESCRIPTION	PART NO.	APPLIES TO	MAJOR REV	COMMENT
(1) MAINS PLATE BRACKET-2.0 IN DIA	100216	ALL COMPRESSORS	-N, -P, -A, -C, -D, -E, -F, -G, -H	Includes fasteners
(1) BRACKET, MAINS PLATE, 2.0 IN DIA	199K0042	ALL COMPRESSORS	-J	Includes fasteners
(1) MAINS PLATE BRACKET-2.5 IN DIA	100217	ALL COMPRESSORS	-N, -P, -A, -C, -D, -E, -F, -G, -H	Includes fasteners
(1) BRACKET, MAINS PLATE, 2.5 IN DIA	199K0041	ALL COMPRESSORS	-J	Includes fasteners
(1) MAINS PLATE BRACKET-3.0 IN DIA	100218	ALL COMPRESSORS	-N, -P, -A, -C, -D, -E, -F, -G, -H	Includes fasteners
(1) BRACKET, MAINS PLATE, 3.0 IN DIA	199K0043	ALL COMPRESSORS	-J	Includes fasteners
(1) MAINS PLATE BRACKET-3.5 IN DIA	100219	ALL COMPRESSORS	-N, -P, -A, -C, -D, -E, -F, -G, -H	Includes fasteners
(1) BRACKET, MAINS PLATE, 3.5 IN DIA	199K0040	ALL COMPRESSORS	-J	Includes fasteners
(2) GROUND POST, MAIN INPUT, 0.3125 IN	100519	ALL COMPRESSORS	-N, -P, -A, -C, -D, -E, -F, -G, -H	Includes fasteners
(2) GROUND POST, MAIN INPUT, 0.375 IN	199K0093	ALL COMPRESSORS	-J	Includes fasteners

4.12 Terminal Block Assembly

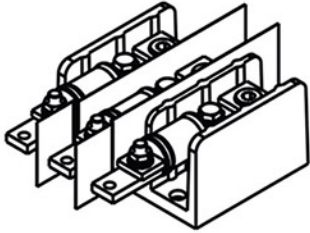

100048-2

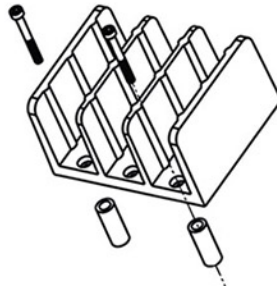

100048-1

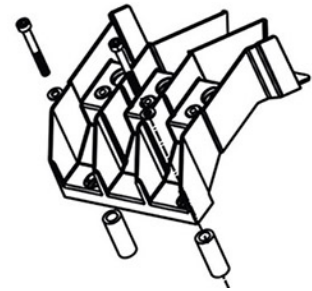

100048-3

DESCRIPTION	PART NO.	APPLIES TO	MAJOR REV	COMMENT
TERMINAL BLOCK AND FUSE ASSY	100048-2	<ul style="list-style-type: none"> TTS300 TGS230 	-N, -P, -C, -D, -E, -F, -G, -H	Replaces Terminal Block assembly, includes fuses, insulator, fuse extension, and fasteners
TERMINAL BLOCK ASSY	100048-1	<ul style="list-style-type: none"> TTS350/TTS400/TTS500/TTS700 TGS310/TGS390/TGS490/TGS520 TTH375/TGH285 	-A, -C, -E, -F	Includes Terminal Block, fasteners, and spacers
TERMINAL BLOCK ASSY	100048-3	<ul style="list-style-type: none"> TTS350/TTS400/TTS450/TTS500/TTS650/TTS700 TGS310/TGS380/TGS390/TGS490/TGS510/TGS520 TTH375/TGH285 	-H, -J	Includes Terminal Block, Bus Bars, fasteners, and spacers

4.13 Terminal Block Bus Bars and Fuses

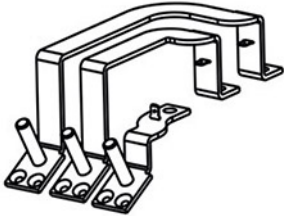

100416



100416-1

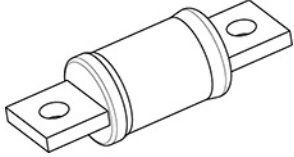

100344

DESCRIPTION	PART NO.	APPLIES TO	MAJOR REV	COMMENT
INPUT MAINS BUS BARS, CURVED	100416	<ul style="list-style-type: none"> TTS350/TTS400/TTS500/TTS700 TGS310/TGS390/TGS490/TGS520 TTH375/TGH285 	-A, -C, -E, -F	Includes three Bus Bars and fasteners
INPUT MAINS BUS BARS, STRAIGHT	100416-1	<ul style="list-style-type: none"> TTS350/TTS400/TTS450/TTS500/TTS650/TTS700 TGS310/TGS380/TGS390/TGS490/TGS510/TGS520 TTH375/TGH285 	-H, -J	Includes three Bus Bars and fasteners
MAINS INPUT FUSE	100344	<ul style="list-style-type: none"> TTS300 TGS230 	-N, -P, -C, -D, -E, -F, -G, -H	Replaces the three fuses in the Terminal Block assembly

4.14 Soft Start Assembly

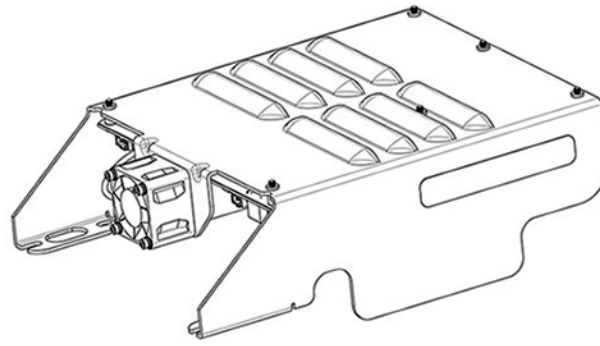

When replacing a Soft Start or a Soft Start Fan, it is important to identify the version of Soft Start installed on the compressor. Refer to Table 4-1 Soft Start Identification. Some replacement Soft Starts will also require an upgrade kit; this will depend on what is currently installed on the compressor. There is also a product label located on the frame of the Soft Start. This label can also be used to identify the version of Soft Start. Refer Figure 4-1 Soft Start Label Examples for the location of the part number and revision for the Soft Start.

It is also important to determine what DC-DC is currently installed on the compressor prior to purchasing a new Soft Start.

Table 4-1 Soft Start Identification

SOFT START IMAGE	INTERNAL PART NO.	DESCRIPTION	FAN
	Legacy model (multiple part numbers)	Slanted side frame	12 VDC Fan
	200193	Exposed circuit board on top	12 VDC Fan
	200095	Larger side frame	24 VDC Fan

Figure 4-1 Soft Start Label Examples



DESCRIPTION	PART NO.	APPLIES TO	MAJOR REV	COMMENT
SOFT START UPGRADE	100020-19	<ul style="list-style-type: none"> TTS300 TGS230 	-N, -P, -C, -D, -E, -F	Includes Soft Start, DC-DC, Soft Start AC/DC Cable, Soft Start SCR Gate Cable, and fasteners
SOFT START, 200193	100020-18	<ul style="list-style-type: none"> TTS300 TGS230 	-G**, -H	Includes fasteners only **Rev G compressors with Potted DC-DC require Soft Start Upgrade Kit (100020-19) instead **Rev G Compressors with Open Frame DC-DC and Soft Starts other than versions 200095 and 200193 require cables 100380-1 and 100059-1 in addition to this kit

NOTE

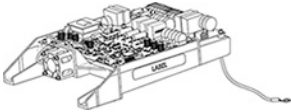
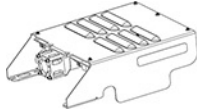
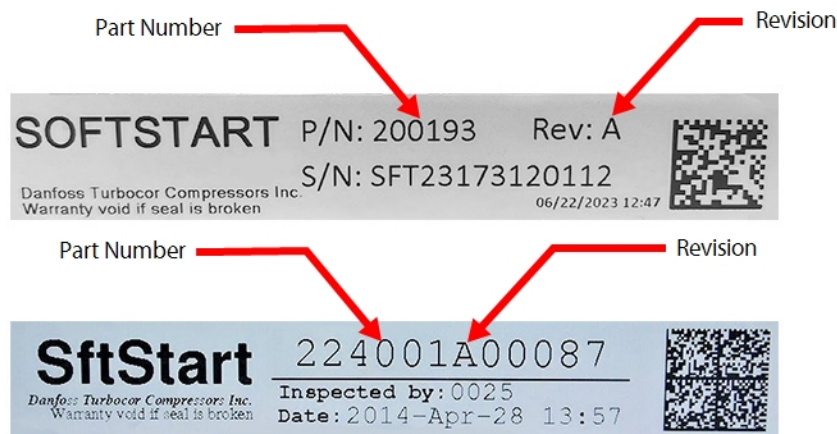
The first compressor to receive the Open Frame DC-DC was S/N **191015180**.

Any compressor prior to S/N **191015180** will require the Soft Start Upgrade Kit if the upgrade was not previously installed.

Soft Start Assembly (continued)

DESCRIPTION	PART NO.	APPLIES TO	MAJOR REV	COMMENT
SOFT START UPGRADE	100020-20	<ul style="list-style-type: none"> TTS350/TTS400/TTS450/TTS500/TTS700 TGS310/TGS380/TGS390/TGS490/TGS520 	-P, -A, -C, -E	Includes Soft Start, DC-DC, Soft Start AC/DC Cable, Soft Start SCR Gate Cable, and fasteners
SOFT START, 200193	100020-18	<ul style="list-style-type: none"> TTS350/TTS400/TTS450/TTS500/TTS700 TGS310/TGS380/TGS390/TGS490/TGS520 TTH375/TGH285 	-F**, -H	Replacement for 200095/200193 Soft Starts Includes fasteners **Rev F compressors with Potted DC-DC require Soft Start Upgrade Kit (100020-20) instead ** Rev F Compressors with Open Frame DC-DC requires cables 100381-2 and 100059-1 in addition to this kit
SOFT START, 200095	199K0053	<ul style="list-style-type: none"> TTS350/TTS650 TGS310/TGS510 TTH375/TGH285 	-J	Includes fasteners



DESCRIPTION	PART NO.	APPLIES TO	MAJOR REV	COMMENT
COOLING FAN AND ADAPTER, 12 VDC	100373-1 (see note below)	ALL COMPRESSORS Using Soft Starts with 12 VDC cooling fan	-N, -P, -A, -C, -D, -E, -F, -G, -H	Includes adapter and fasteners Do NOT install on Soft Starts 200095
COOLING FAN, 24 VDC	199K0054 (see note below)	ALL COMPRESSORS Using Soft Starts with 24 VDC cooling fan	-J (and compressors converted to the 200095 Soft Start)	Includes fasteners To only be installed on Soft Starts 200095
HARDWARE, SOFT START BRACKET AND FAN	199K0055	ALL COMPRESSORS Using 200095 Soft Starts	-J (and compressors converted to the 200095 Soft Start)	Fasteners only (fan and compressor mounting fasteners) Only for 200095 Soft Starts

NOTE

The version of Soft Start must be determined in order to identify the correct cooling fan. As stated above, there are two different cooling fans and they are not interchangeable. To properly determine the correct version of Soft Start and cooling fan, refer to the Soft Start label which is located on the frame of the Soft Start (refer to Figure 4-1 Soft Start Label Examples). If the Soft Start is part number 200095, the fan is 24 VDC. If the label indicates any other part number, then the fan is 12 VDC.

4.15 Soft Start Fuses

DESCRIPTION	PART NO.	APPLIES TO	MAJOR REV	COMMENT
FUSES, SOFT START	100317-1	ALL COMPRESSORS	-N, -P, -A, -C, -D, -E, -F, -G	Fuses included: QTY 3 - 2A HVA (F1), QTY 3 - 2A SPF (F1), QTY 10 - 1A Nano (F3, F6), QTY 10 - 0.25A Nano (F2), and QTY 6 - 0.25A Midget (F4, F5)
FUSES, SOFT START	100317-2	ALL COMPRESSORS	-F, -G	For Soft Starts Rev Q and later, Fuses included: QTY 3 - 2A SPF (F1), QTY 10 - 1A Nano (F3, F6), QTY 10 - Nano 0.25A (F2), and QTY 6 - 0.25A Midget (F4, F5)
FUSE, NANO, SMF, 0.25A 125V	100430	ALL COMPRESSORS	-N, -P, -A, -C, -D, -E, -F, -G	Includes 10 fuses
FUSE, MIDGET, TIME DELAY, 0.2A, 600V	100432	ALL COMPRESSORS	-N, -P, -A, -C, -D, -E, -F, -G	Includes six fuses
FUSE, NANO, 1A 125V	100433	ALL COMPRESSORS	-N, -P, -A, -C, -D, -E, -F, -G	Includes 10 fuses
FUSE, 2A, 1000V, 3IN	100421	<ul style="list-style-type: none"> TTS300/TTS350/TTS400/TTS450/TTS500/TTS700 TGS230/TGS310/TGS380/TGS390/TGS490/TGS520 	-N, -P, -A, -C, -D, -E	For Soft Starts Rev P and earlier, includes three fuses
FUSE, 2A, 1000V	100422	<ul style="list-style-type: none"> TTS300/TTS350/TTS400/TTS450/TTS500/TTS700 TGS230/TGS310/TGS380/TGS390/TGS490/TGS520 TTH375/TGH285 	-F, -G	For Soft Starts Rev Q and later, includes three fuses

NOTE

There are no fuses required if the compressor is equipped with either a 200095 or 200193 Soft Start.

4.16 Pressure Temperature Sensor Discharge

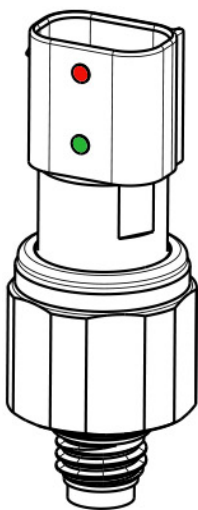

DESCRIPTION	PART NO.	APPLIES TO	MAJOR REV	COMMENT
*PRESSURE/TEMP SENSOR, DISCHARGE	100037-2	ALL COMPRESSORS	ALL	Marked with a red dot and a green dot, contains O-ring
O-RING, P/T SENSORS	199K0015	ALL COMPRESSORS	ALL	Includes four O-rings

* Also replaces the TTH/TGH compressor Interstage Pressure/Temperature Sensor.

4.17 Silicone-Controlled Rectifiers (SCRs)

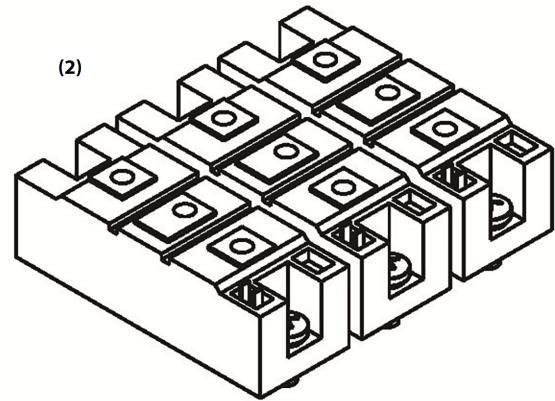
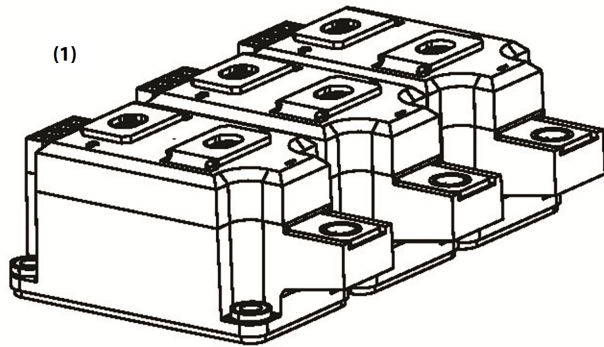

DESCRIPTION	PART NO.	APPLIES TO	MAJOR REV	COMMENT
(2) SILICONE CONTROLLED RECTIFIERS	100047-1	<ul style="list-style-type: none"> TTS300 TGS230 	-N, -P, -C, -D, -E, -F, -G, -H	Includes fasteners Not interchangeable with Kit 100047-3
(2) SILICONE CONTROLLED RECTIFIERS	100047-1	<ul style="list-style-type: none"> TTS400 TGS390 	-H	Includes fasteners Not interchangeable with Kit 100047-3
(1) SILICONE CONTROLLED RECTIFIERS	100047-2	<ul style="list-style-type: none"> TTS350/TTS500/TTS700 TGS310/TGS490/TGS520 TTH375/TGH285 	-A, -C, -E, -F	Includes fasteners
(1) SILICONE CONTROLLED RECTIFIERS	100047-2	<ul style="list-style-type: none"> TTS400 TGS390 	-P, -A, -C, -E, -F	Includes fasteners
(2) SILICONE CONTROLLED RECTIFIERS	100047-3	<ul style="list-style-type: none"> TTS350/TTS450/TTS500/TTS650/TTS700 TGS310/TGS380/TGS490/TGS510/TGS520 TTH375/TGH285 	-H, -J	Includes fasteners Not interchangeable with Kit 100047-1

NOTE

SCRs should always be replaced as a kit.

4.18 Bus Bar

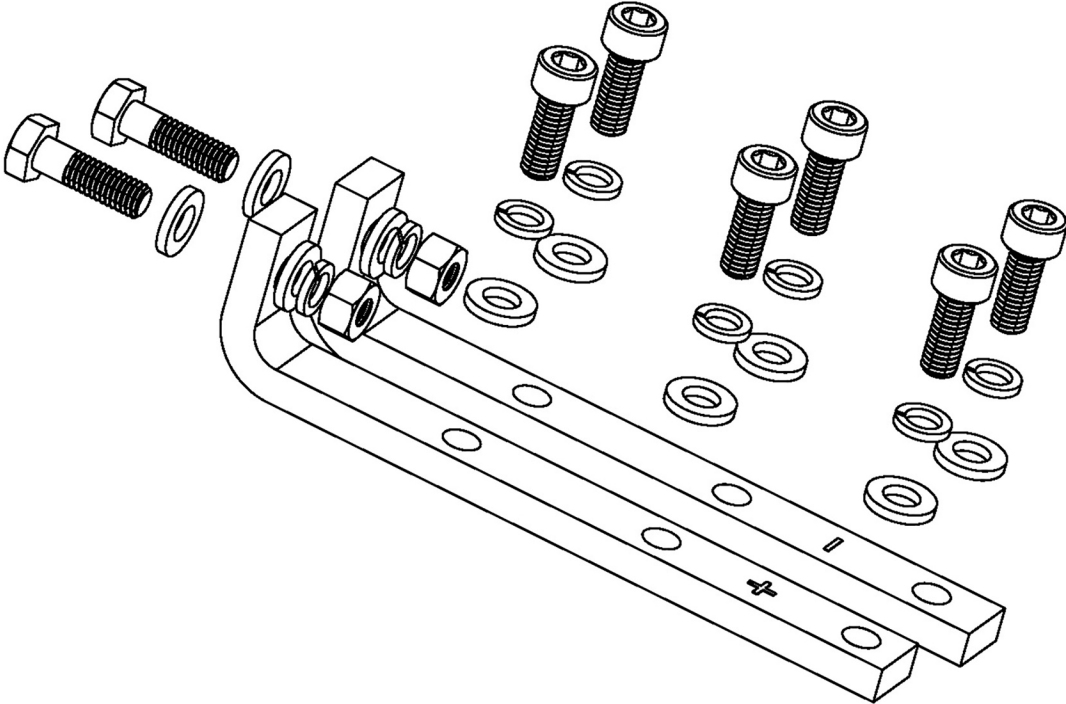

DESCRIPTION	PART NO.	APPLIES TO	MAJOR REV	COMMENT
SCR BUS BAR	100316	<ul style="list-style-type: none"> TTS300 TGS230 	ALL	Includes positive and negative Bus Bars and fasteners

4.19 Snubber Capacitors

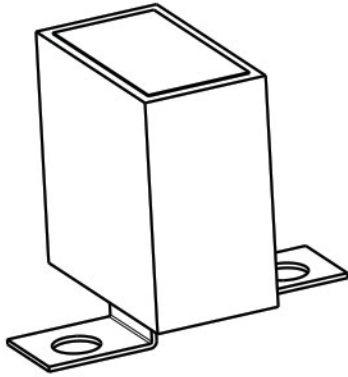

199K0045

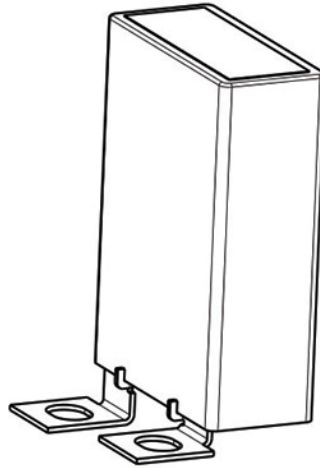

199K0078

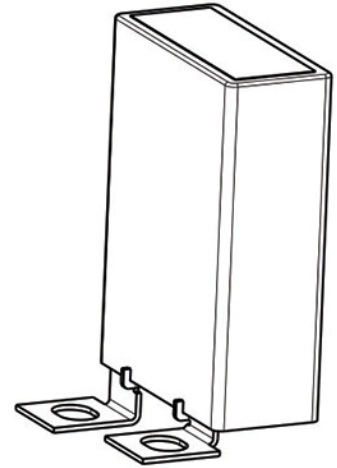

199K0044

DESCRIPTION	PART NO.	APPLIES TO	MAJOR REV	COMMENT
SNUBBER CAPACITOR, 0.47 μ F, 1000VDC	199K0045	<ul style="list-style-type: none"> TTS300 TGS230 	-N, -P, -C, -D, -E, -F, -G	Includes three snubbers and fasteners
SNUBBER CAPACITOR, 0.56 μ F, 1000VDC	199K0078	<ul style="list-style-type: none"> TTS300 TGS230 	-H	Includes three snubbers and fasteners
INVERTER SNUBBER CAPACITOR, 0.56 μ F, 1000VDC	199K0044	<ul style="list-style-type: none"> TTS350/TTS400/TTS500/TTS650/TTS700 TGS310/TGS390/TGS490/TGS510/TGS520 TTH375/TGH285 	-P, -A, -C, -E, -F, -H, -J	Includes three snubbers and fasteners

NOTE

Snubber capacitors should always be replaced as a set of three.

4.20 SCR Heatsink Assembly

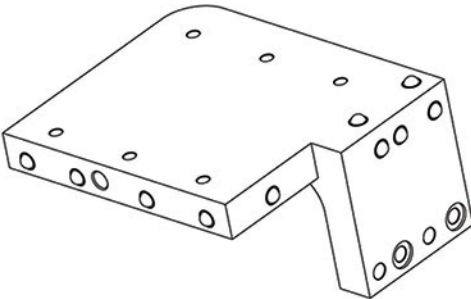

100309-11

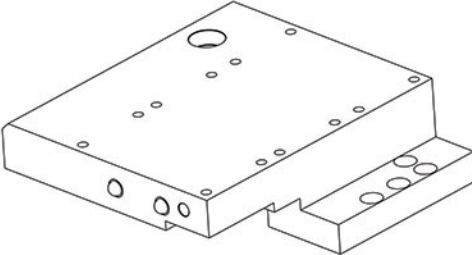

100309-13

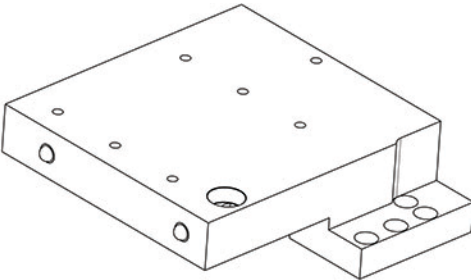

100309-8

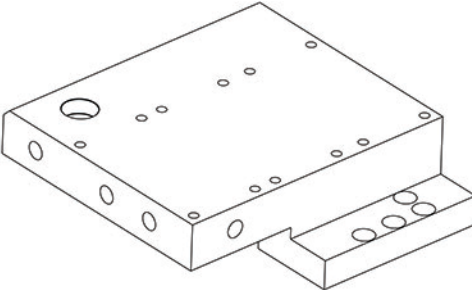

100309-7

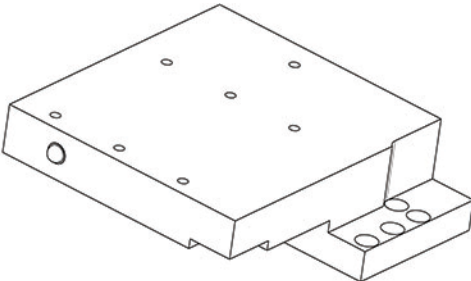

199K0024

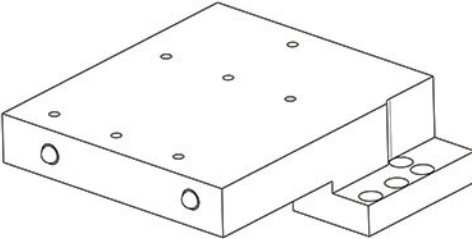

199K0079



100268

DESCRIPTION	PART NO.	APPLIES TO	MAJOR REV	COMMENT
SCR COOLING MANIFOLD	100309-11	<ul style="list-style-type: none"> TTS300 TGS230 	ALL	Includes O-rings and fasteners (sensor not applicable)
SCR COOLING MANIFOLD	100309-13	<ul style="list-style-type: none"> TTS350/TTS400/TTS500/TTS700 TGS310/TGS390/TGS490/TGS520 	-P, -A, -C, -E, -F	Includes O-rings and fasteners (sensor not applicable) Standard SST models only
SCR COOLING MANIFOLD	199K0024	<ul style="list-style-type: none"> TTS350/TTS400/TTS450/TTS650/TTS700 TGS310/TGS380/TGS390/TGS490/TGS520/TGS520 	-H, -J (Standard SST)	Includes O-rings, SCR Manifold Return Fitting, and fasteners (sensor not applicable) Standard SST models only
SCR COOLING MANIFOLD	100309-8	<ul style="list-style-type: none"> TTS350/TTS400/TTS450/TTS700 TGS310/TGS380/TGS390/TGS490/TGS520 TTH375/TGH285 (all models) 	-H (High SST)	High SST Option Includes O-rings, SCR Manifold Return Fitting, and fasteners (sensor not applicable) Refer to Note 2 when converting to High SST Not interchangeable with Kit 100309-7
SCR COOLING MANIFOLD	100309-7	<ul style="list-style-type: none"> TTH375/TGH285 	-F, -G	Includes O-rings and fasteners Not interchangeable with Kit 100309-8 Both standard and high SST
SCR COOLING MANIFOLD	199K0079	<ul style="list-style-type: none"> TTS350/TTS650 TGS310/TGS510 TTH375/TGH285 	-J	Includes O-rings and fasteners (High SST and Active Cooling)
O-RINGS, SCR COOLING MANIFOLD	100310-2	<ul style="list-style-type: none"> TTS300 TGS230 	ALL	Replaces Inverter, SCR Heatsink Manifold O-rings, and fasteners
O-RINGS, SCR COOLING MANIFOLD	100310-1	<ul style="list-style-type: none"> TTS350/TTS400/TTS450/TTS500/TTS650/TTS700 TGS310/TGS380/TGS390/TGS490/TGS510/TGS520 TTH375/TGH285 	ALL	Replaces Inverter, SCR Heatsink Manifold O-rings, and fasteners

DESCRIPTION	PART NO.	APPLIES TO	MAJOR REV	COMMENT
(6) SCR COOLING MANIFOLD TEMP SENSOR	100268	<ul style="list-style-type: none"> TTS300/TTS350/TTS400/TTS500/TTS700 TGS230/TGS310//TGS390/TGS490/TGS520 	-N, -P, -A, -C, -D, -E, -F, -G	Includes washers Will not work in Rev H compressors

NOTE 1

The SCR Temperature Sensor is not required on Revision H compressors.

NOTE 2

A TTS/TGS model series standard temperature compressor can be converted to a high temperature compressor. To do so, the following items are required:

- 100309-8 - Heatsink, Cooling Manifold SCR Assembly
- 201055-xxxxxxx-xxx 4.3.0 BMCC*
- 199K0044 - CAPACITOR INVERTER SNUBBER, 0.56 μ F, 1000VDC

*BMCC PNs are not unique between application option ST (Standard Temperature) and HT (High Temperature); however, HT applications require software version 4.3.0 and later to operate.

The SCR Manifold Return Brass Fitting may be required to be replaced if the compressor was manufactured after May 31, 2024. The brass fitting is included in kit 100309-8. Refer to the SCR Cooling Manifold Instructions for more information.

4.21 Active Cooling Components

This section details the spare part kits that are specific to our Active Cooling compressors. All Active Cooling compressors are Major Revision J.

Figure 4-2 Active Cooling Components

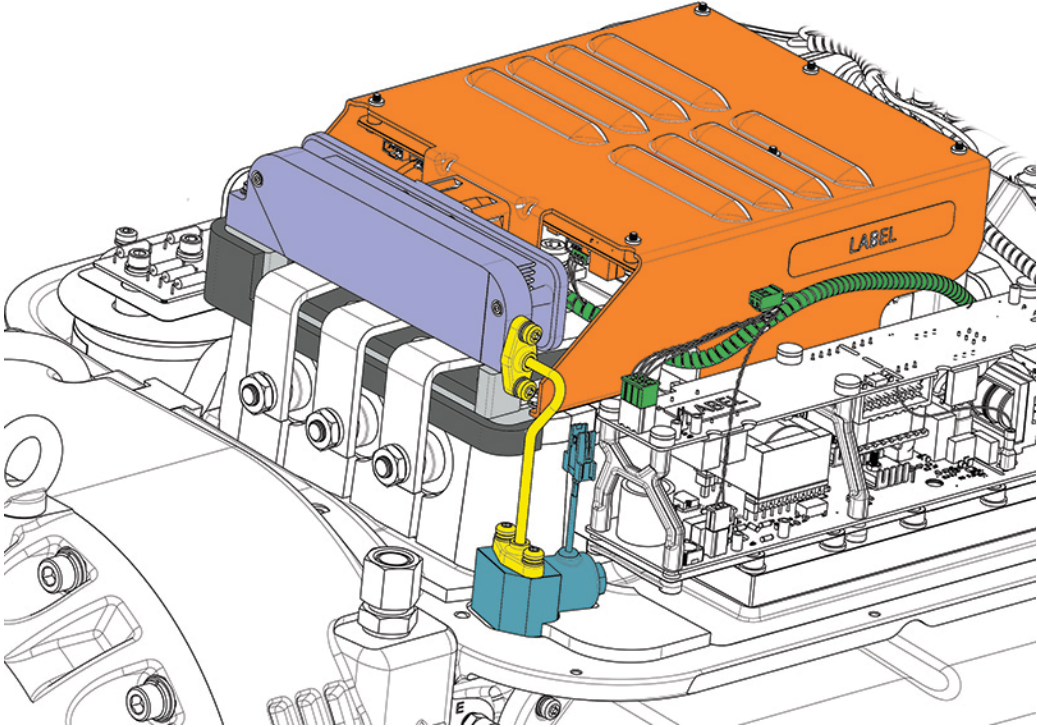

4.21.1 Heat Exchanger

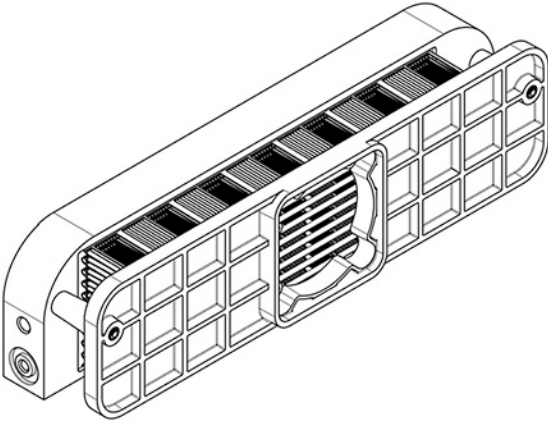

DESCRIPTION	PART NO.	APPLIES TO	MAJOR REV	COMMENT
HEAT EXCHANGER	199K0005	<ul style="list-style-type: none"> TTS350 TGS310 TTH375/TGH285 	-J	Includes Heat Exchanger, fasteners, and O-rings
O-RINGS, HEAT EXCHANGER	199K0018	<ul style="list-style-type: none"> TTS350 TGS310 TTH375/TGH285 	-J	Includes fasteners and O-rings

4.21.2 Inlet Pipe

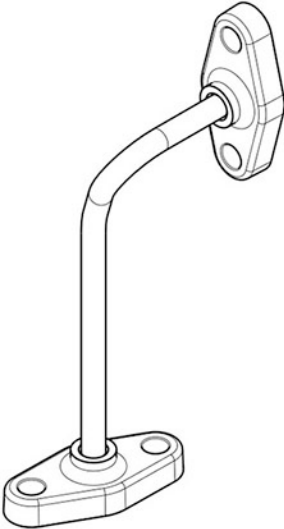

DESCRIPTION	PART NO.	APPLIES TO	MAJOR REV	COMMENT
INLET PIPE	199K0006	<ul style="list-style-type: none"> TTS350 TGS310 TTH375/TGH285 	-J	Includes Inlet Pipe, fasteners, and O-rings
O-RINGS, INLET PIPE	199K0019	<ul style="list-style-type: none"> TTS350 TGS310 TTH375/TGH285 	-J	Includes fasteners and O-rings

4.21.3 Solenoid

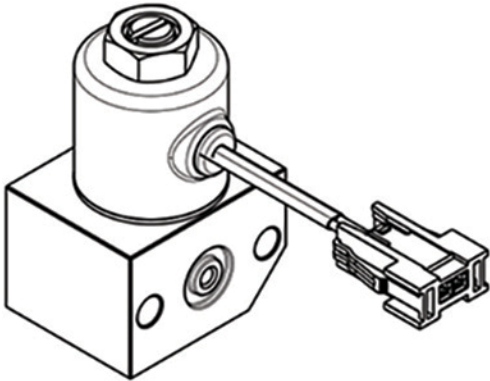

DESCRIPTION	PART NO.	APPLIES TO	MAJOR REV	COMMENT
SOLENOID, ACTIVE COOLING	199K0007	<ul style="list-style-type: none"> • TTS350 • TGS310 • TTH375/TGH285 	-J	Includes solenoid, fasteners, and O-rings
O-RINGS, SOLENOID	199K0051	<ul style="list-style-type: none"> • TTS350 • TGS310 • TTH375/TGH285 	-J	Includes fasteners and O-rings

4.21.4 Cover Plate

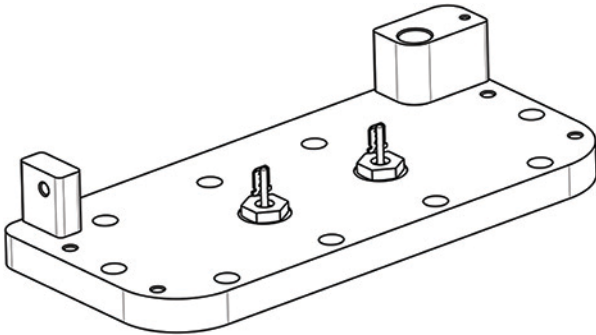

DESCRIPTION	PART NO.	APPLIES TO	MAJOR REV	COMMENT
COVER PLATE, ACTIVE COOLING	199K0008	<ul style="list-style-type: none"> TTS350 TGS310 TTH375/TGH285 	-J	Includes required O-rings, insulation, and fasteners
O-RINGS-COVER PLATE	199K0052	<ul style="list-style-type: none"> TTS350 TGS310 TTH375/TGH285 	-J	Includes required O-rings and fasteners

4.21.5 Blanking Plate

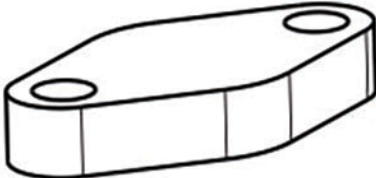

DESCRIPTION	PART NO.	APPLIES TO	MAJOR REV	COMMENT
BLANKING PLATE, ACTIVE COOLING	199K0014	ALL COMPRESSORS	-J	Used to Seal Active Cooling Port for Non-Active Cooling Models Includes O-ring and fasteners

Chapter 5.0 Capacitor Side

This section details the spare part kits that are visible from the discharge side of the compressor underneath the Capacitor and Mains Input cover.

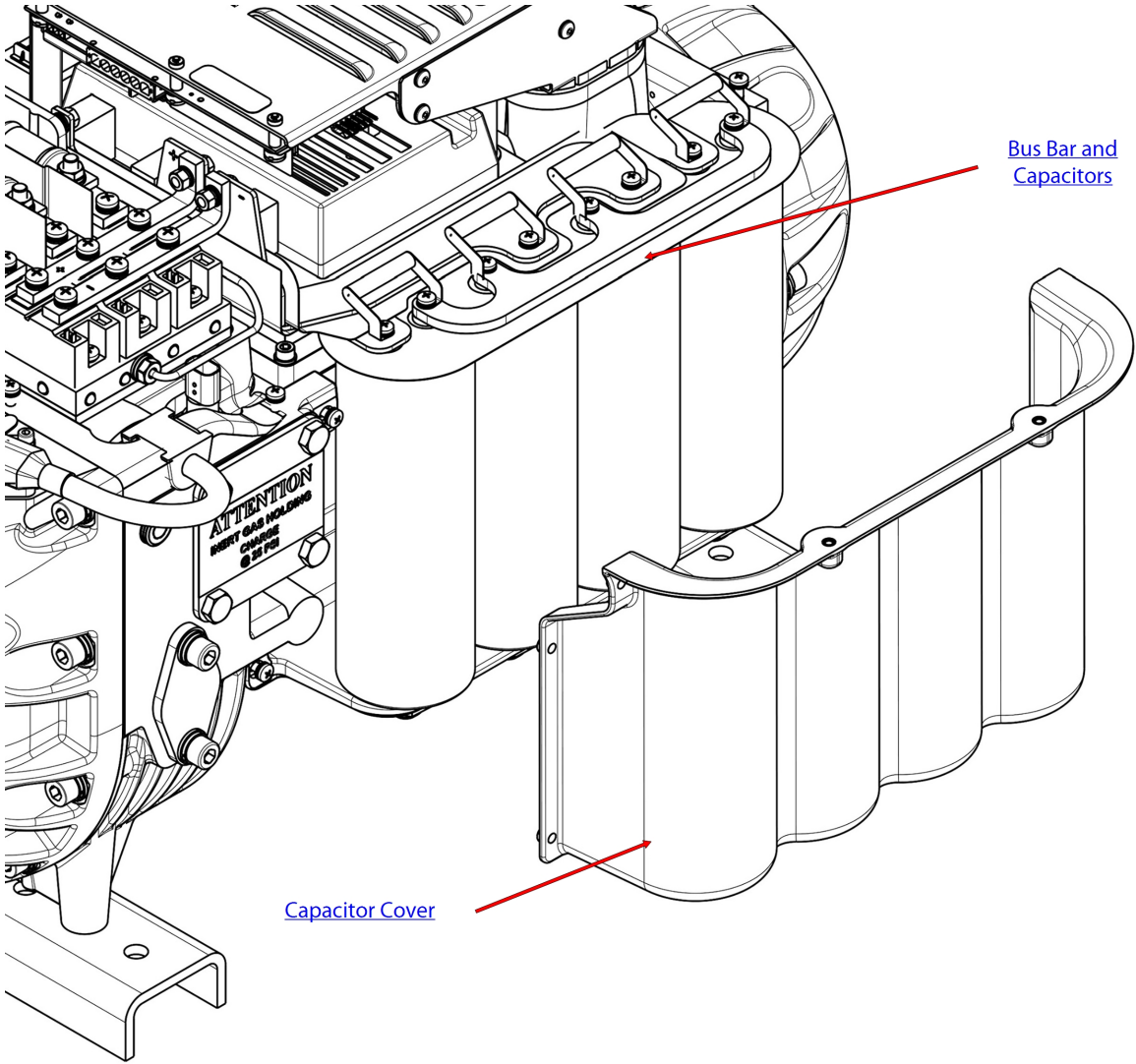

5.1 Capacitor Cover

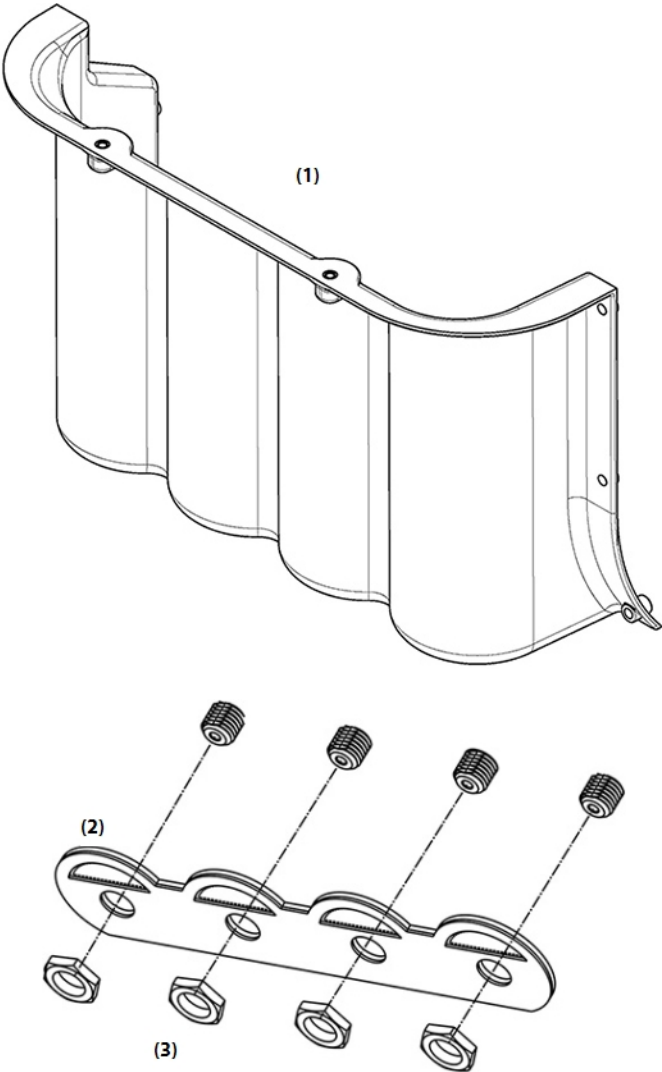

DESCRIPTION	PART NO.	APPLIES TO	MAJOR REV	COMMENT
(1) CAPACITOR COVER, BLACK	100053-3	<ul style="list-style-type: none"> • TT300/TTS350/TS3TS400/TTS450/TTS500/TTS650/TTS700 • TTH375 	ALL	Includes fasteners
(1) CAPACITOR COVER, GREEN	100053-6	<ul style="list-style-type: none"> • TGS230/TGS310/TGS380/TGS390/TGS490/TGS510/TGS520 • TGH285 	ALL	Includes fasteners
(2) & (3) CAP MEMBRANE	100122	ALL COMPRESSORS	ALL	Includes nylon hex nuts
COVERS SCREW, M5, STAINLESS	100252	ALL COMPRESSORS	ALL	Replaces fasteners for all four covers (24 fasteners)

5.2 Bus Bar and Capacitor Assembly

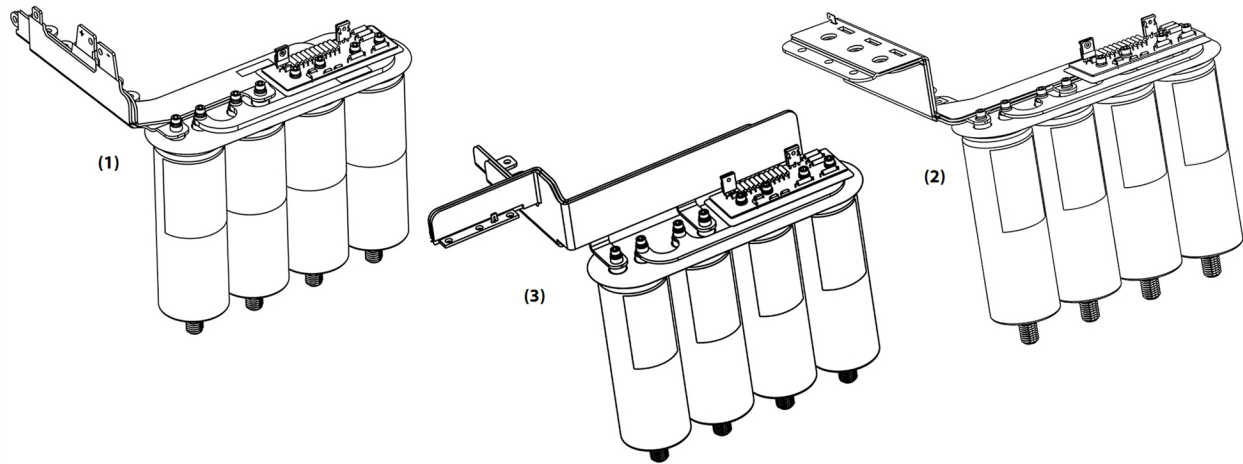

DESCRIPTION	PART NO.	APPLIES TO	MAJOR REV	COMMENT
(1) DC CAPACITOR ASSY, 6800 μ F (460V)	100044-7	<ul style="list-style-type: none"> TTS300/TGS230 	-N, -P, -C, -D, -E, -F, -G, -H	For use with 460V models; includes relief membrane and nylon nuts
(1) DC CAPACITOR ASSY, 4700 μ F (575V)	100044-8	<ul style="list-style-type: none"> TTS300/TGS230 	-N, -P, -C, -D, -E, -F, -G, -H	For use with 575V models; includes relief membrane and nylon nuts
(1) DC CAPACITOR ASSY, 9000 μ F (380/400V)	100044-6	<ul style="list-style-type: none"> TTS300/TGS230 	-N, -P, -C, -D, -E, -F, -G, -H	For use with 380/400V models; includes relief membrane and nylon nuts
(2) DC CAPACITOR ASSY, 11000 μ F (380/400V)	100044-11	<ul style="list-style-type: none"> TTS350/TTS400/TTS500/TTS700 TGS310/TGS390/TGS490/TGS520 TTH375/TGH285 	-P, -A, -C, -E, -F	For use with 380V and 400V models; includes relief membrane and nylon nuts
(3) DC CAPACITOR ASSY, 11000 μ F (380/400V)	100044-14	<ul style="list-style-type: none"> TTS350/TTS400/TTS450/TTS500/TTS700 TGS310/TGS380/TGS390/TGS490/TGS520 TTH375/TGH285 	-H	For use with 380V and 400V models, includes nylon nuts
(3) DC CAPACITOR ASSY, 11000 μ F (380/400V)	199K0068	<ul style="list-style-type: none"> TTS350/TTS650 TGS310/TGS510 TTH375/TGH285 	-J	For use with 380V and 400V models, includes nylon nuts
(2) DC CAPACITOR ASSY, 6800 μ F (575V)	100044-13	<ul style="list-style-type: none"> TTS350/TTS400/TTS500/TTS700 TGS310/TGS390/TGS490/TGS520 TTH375/TGH285 	-C, -E, -F	For use with 575V models; includes relief membrane and nylon nuts

DESCRIPTION	PART NO.	APPLIES TO	MAJOR REV	COMMENT
(3) DC CAPACITOR ASSY, 6800µF (575V)	100044-16	<ul style="list-style-type: none"> TTS350/TTS400/TTS450/TTS500/TTS700 TGS310/TGS380/TGS390/TGS490/TGS520 TTH375/TGH285 	-H	For use with 575V models; includes relief membrane and nylon nuts
(3) DC CAPACITOR ASSY, 6800µF (575V)	199K0069	<ul style="list-style-type: none"> TTS350/TTS650 TGS310/TGS510 TTH375/TGH285 	-J	For use with 575V models; includes relief membrane and nylon nuts
(2) DC CAPACITOR ASSY, 8500µF (460V)	100044-12	<ul style="list-style-type: none"> TTS350/TTS400/TTS500/TTS700 TGS310/TGS390/TGS490/TGS520 TTH375/TGH285 	-P, -A, -C, -E, -F	For use with 460V models; includes relief membrane and nylon nuts
(3) DC CAPACITOR ASSY, 8500µF (460V)	100044-15	<ul style="list-style-type: none"> TTS350/TTS400/TTS450/TTS500/TTS700 TGS310/TGS380/TGS390/TGS490/TGS520 TTH375/TGH285 	-H	For use with 460V models; includes relief membrane and nylon nuts
(3) DC CAPACITOR ASSY, 8500µF (460V)	199K0070	<ul style="list-style-type: none"> TTS350/TTS650 TGS310/TGH510 TTH375/TGH285 	-J	For use with 460V models; includes relief membrane and nylon nuts

Chapter 6.0 Service Side

This section details the spare part kits available on the service side of the compressor underneath the Service Side cover.

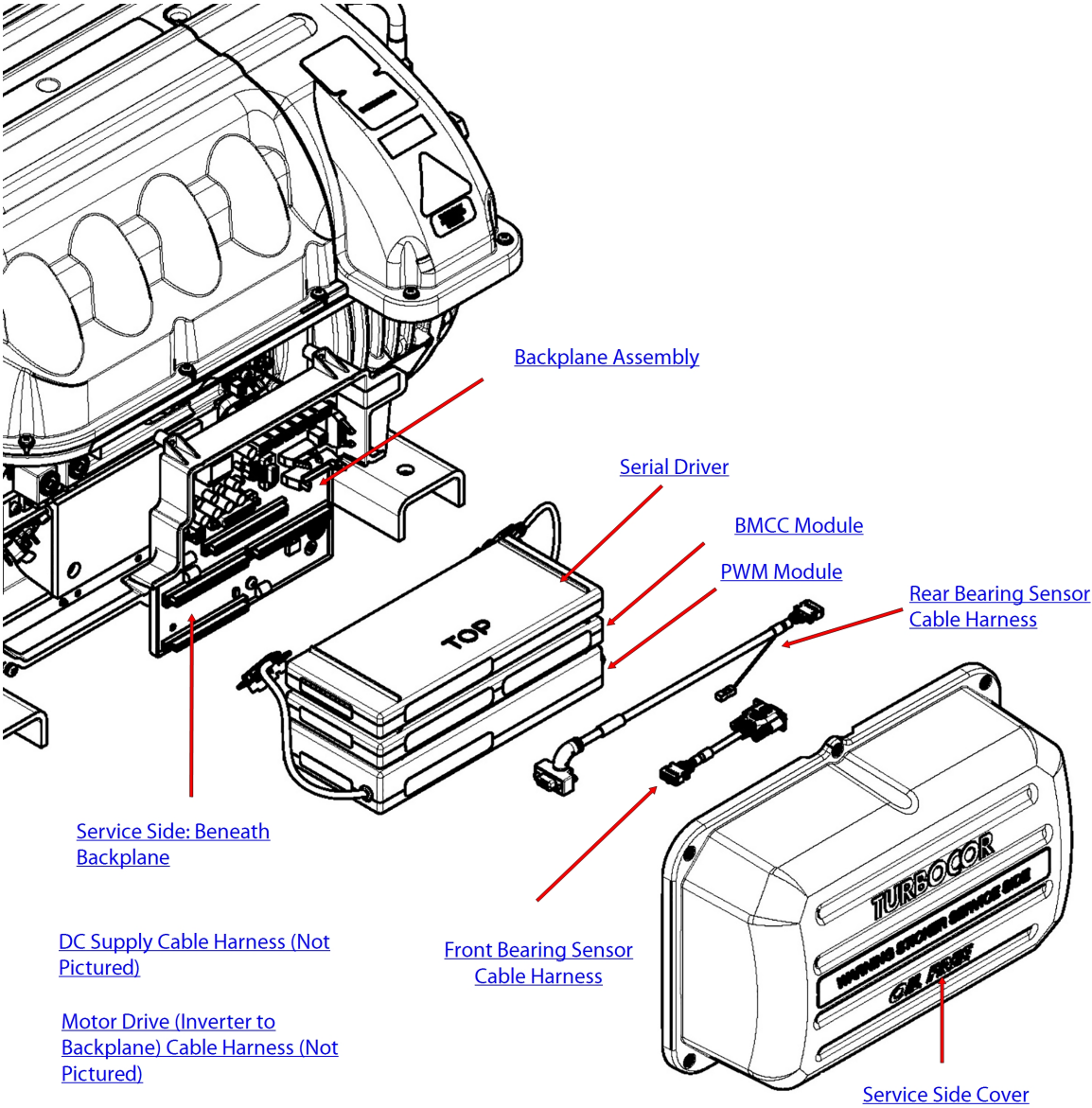

6.1 Service Side Cover



DESCRIPTION	PART NO.	APPLIES TO	MAJOR REV	COMMENT
SERVICE SIDE COVER, BLACK	100055-3	<ul style="list-style-type: none"> TTS300/TTS350/TTS400/TTS450/TTS500/TTS650/TTS700 TTH375 	ALL	Includes fasteners
SERVICE SIDE COVER, GREEN	100055-6	<ul style="list-style-type: none"> TGS230/TGS310/TGS380/TGS390/TGS490/TGS510/TGS520 TGH285 	ALL	Includes fasteners
COVERS SCREW, M5, STAINLESS	100252	ALL COMPRESSORS	ALL	Replaces fasteners for all four covers (24 fasteners)

6.2 Pulse Width Modulation (PWM) Module

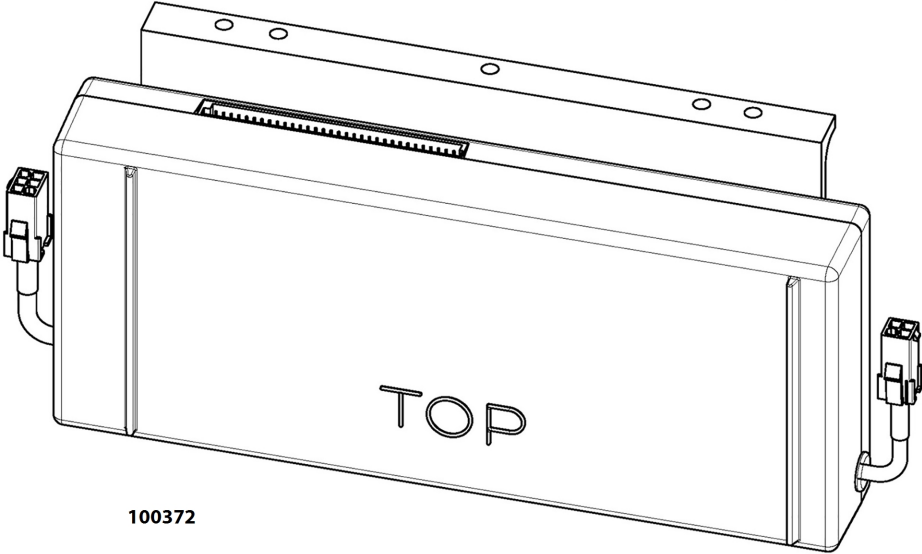
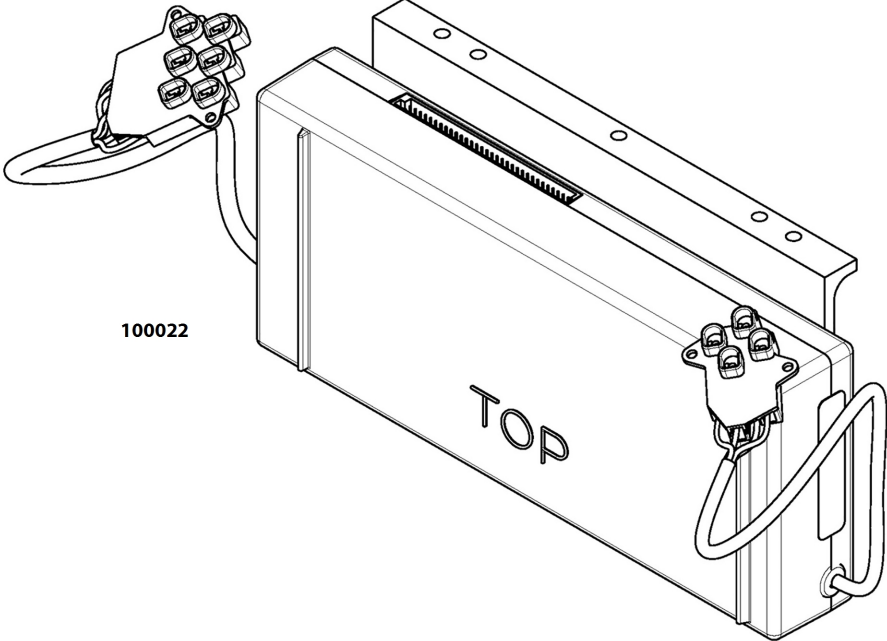

DESCRIPTION	PART NO.	APPLIES TO	MAJOR REV	COMMENT
BEARING PWM	100022	ALL COMPRESSORS	-N, -P, -A, -C, -D, -E	Includes fasteners
BEARING PWM	100372	ALL COMPRESSORS	-F, -G, -H, -J	Includes fasteners

6.3 Bearing Motor Compressor Control (BMCC) Module

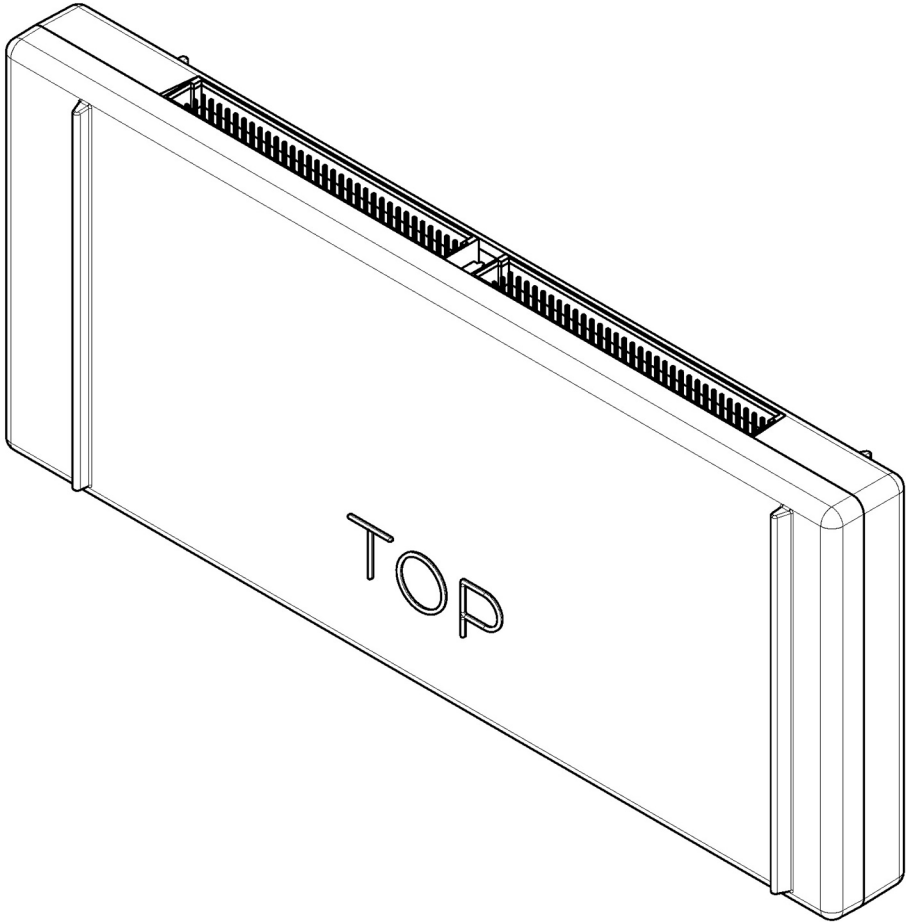

DESCRIPTION	PART NO.	APPLIES TO	MAJOR REV	COMMENT
BEARING MOTOR COMPRESSOR CONTROL (BMCC)	201055- xxxxxxx-xxx	ALL COMPRESSORS	ALL	Specific compressor software part number used in place of -xxxxxxx-xxx Contains BMCC with compressor specific software only

NOTE

Specific BMCC part numbers can be found in Customer Notification B-CN-181.

6.4 Serial Driver

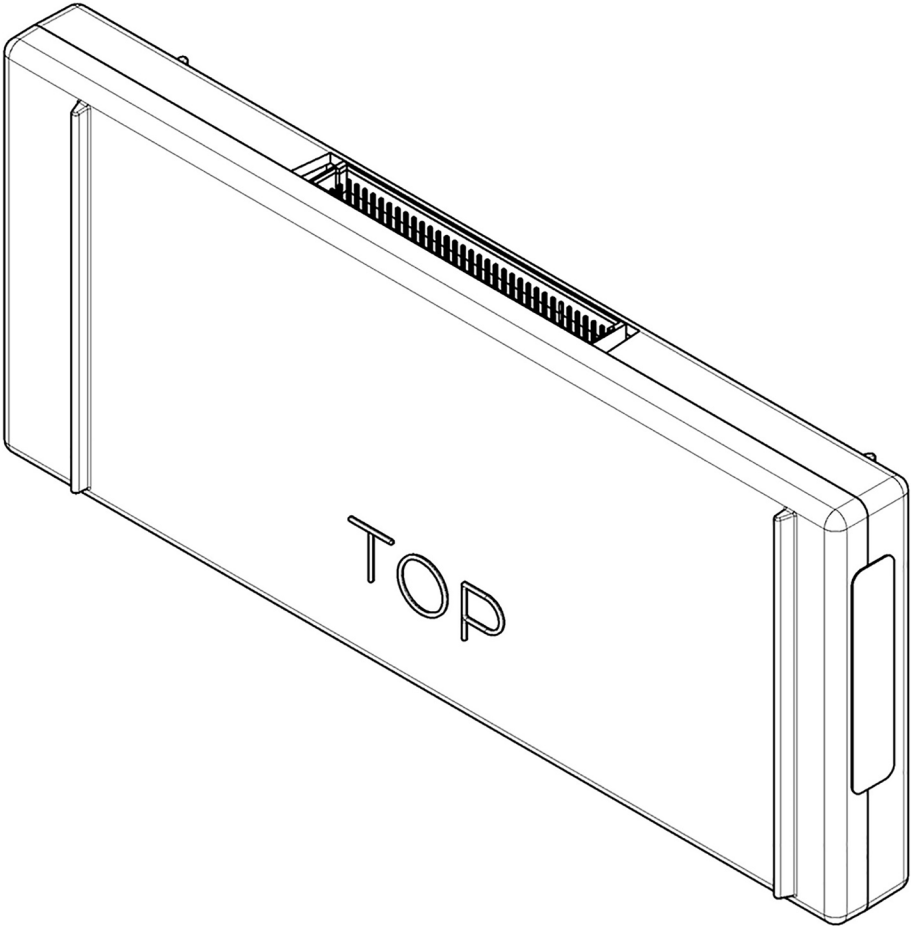

DESCRIPTION	PART NO.	APPLIES TO	MAJOR REV	COMMENT
SERIAL DRIVER	100292	ALL COMPRESSORS	ALL	Serial Driver Only

6.5 Rear/ Front Bearing Sensor Cable Harness

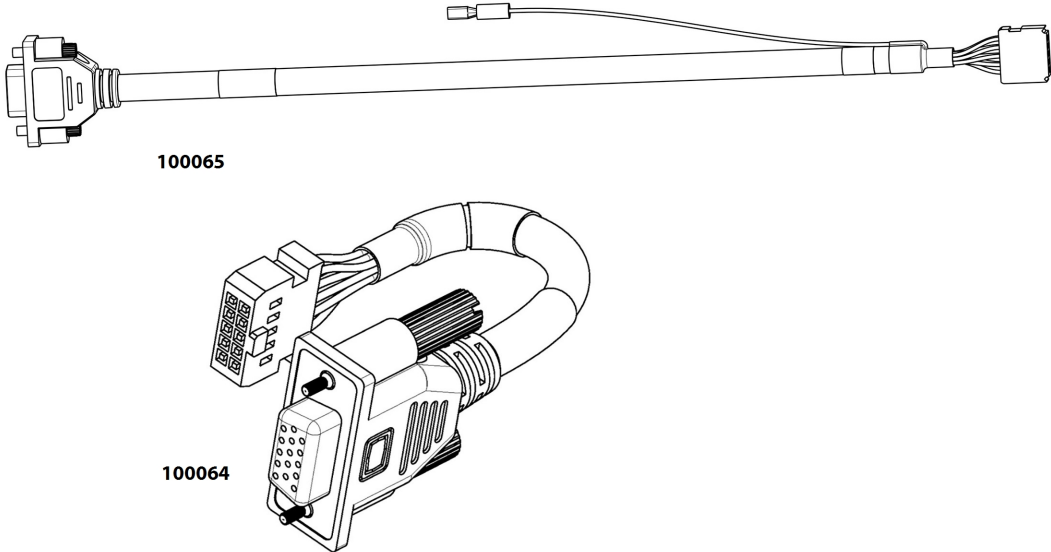

NOTE

For Major Revision J compressors, refer to Section 6.14 9-Pin Hermetic Feedthrough on page 88. Major revision J compressors utilize an integrated cable and feedthrough.

DESCRIPTION	PART NO.	APPLIES TO	MAJOR REV	COMMENT
REAR BEARING SENSOR CABLE HARNESS	100065	ALL COMPRESSORS	-N, -P, -A, -C, -D, -E, -F, -G, -H	Cable Only
FRONT BEARING SENSOR CABLE HARNESS	100064	ALL COMPRESSORS	-N, -P, -A, -C, -D, -E, -F, -G, -H	Cable Only

6.6 Backplane Assembly

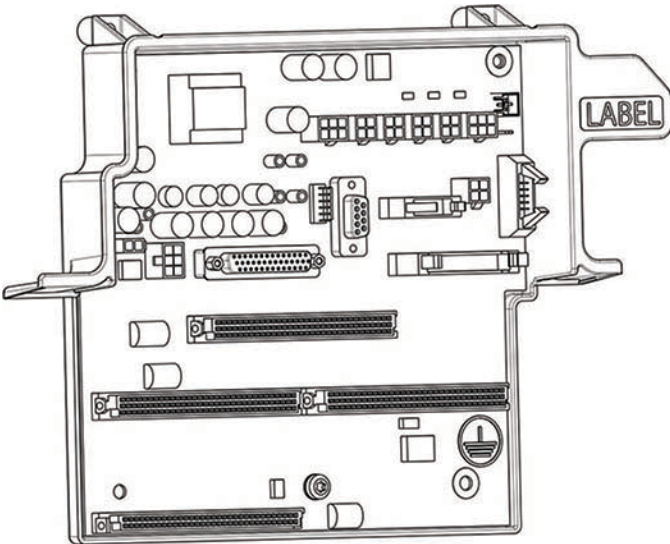

100021-2

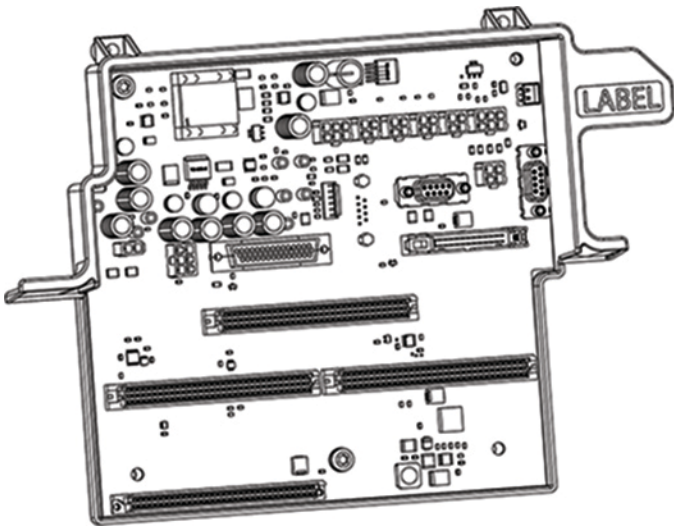

199K0075

NOTE

The primary difference between the two Backplanes lies in the J9 and J10 connectors for the Bearing Sensor Feedthroughs. Major Revision J compressors feature upgraded front and rear Bearing Sensor Feedthroughs, and their external connectors are compatible exclusively with the Major Rev J Backplane. These new Bearing Sensor Feedthroughs can only be utilized on pre-Revision J compressors if the Backplane is also upgraded.

DESCRIPTION	PART NO.	APPLIES TO	MAJOR REV	COMMENT
BACKPLANE ASSEMBLY	100021-2	ALL COMPRESSORS	-N, -P, -A, -C, -D, -E, -F, -G, -H	Includes fasteners
BACKPLANE ASSEMBLY	199K0075	<ul style="list-style-type: none"> • TTS450/TTS650 • TGS380/TGS510 • TTH375/TGH285 	-J	Includes fasteners
HARDWARE, BACKPLANE ASSEMBLY	199K0076	ALL COMPRESSORS	-N, -P, -A, -C, -D, -E, -F, -G, -H, -J	Fasteners only

6.7 DC Supply Cable Harness



DESCRIPTION	PART NO.	APPLIES TO	MAJOR REV	COMMENT
DC SUPPLY CABLE HARNESS	100323	ALL COMPRESSORS	-N, -P, -A, -C, -D, -E	Cable Only
DC SUPPLY CABLE HARNESS	100323-2	ALL COMPRESSORS	-F, -G, -H	Cable Only Soft Start Temperature Sensor is only required in CC Firmware Revision 4.x and later
DC SUPPLY CABLE HARNESS	199K0056	<ul style="list-style-type: none"> TTS450/TTS650 TGS380/TGS510 TTH375/TGH285 	-J	Cable Only

6.8 Motor Drive (Inverter to Backplane) Cable Harness



DESCRIPTION	PART NO.	APPLIES TO	MAJOR REV	COMMENT
MOTOR DRIVE CABLE HARNESS	100061	ALL COMPRESSORS	ALL	Cable Only

6.9 Service Side Beneath Backplane

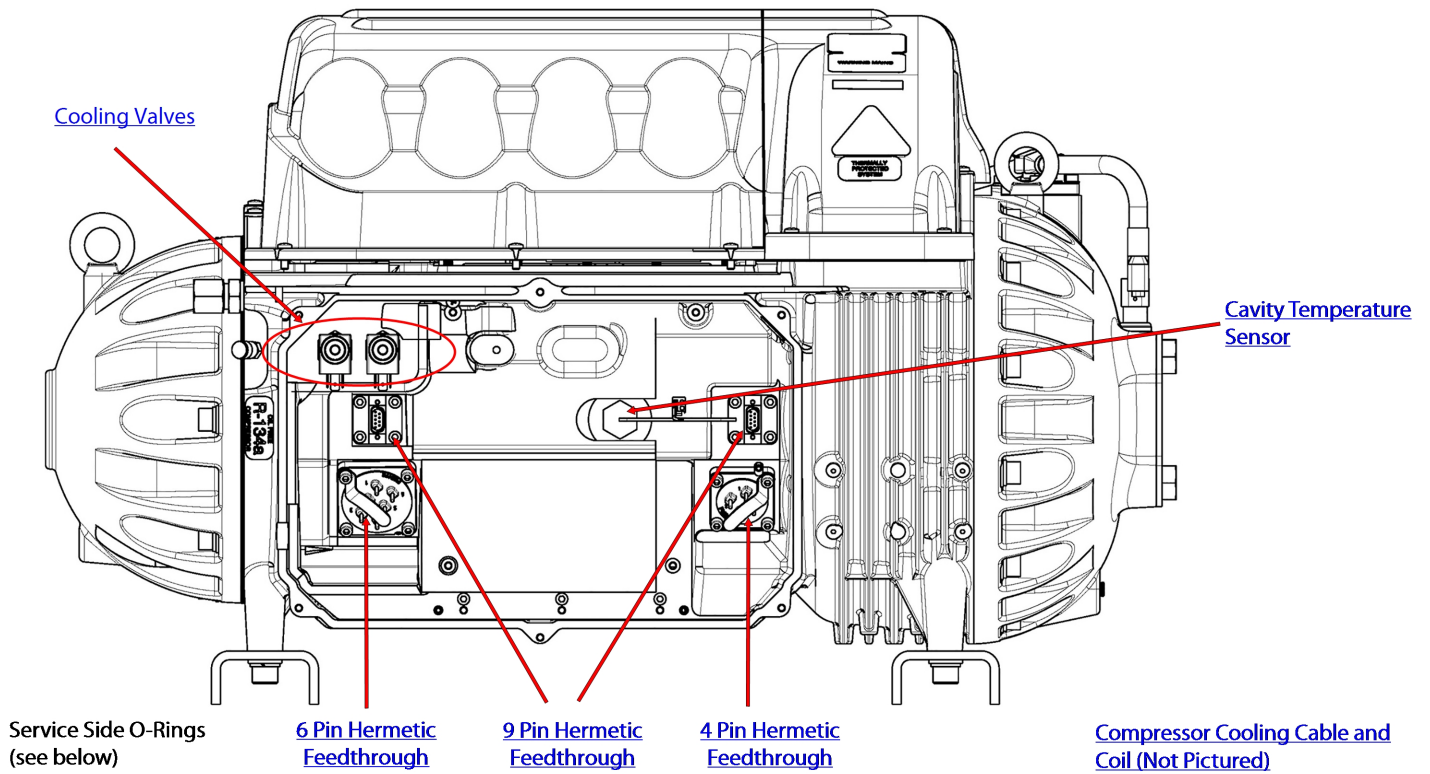

DESCRIPTION	PART NO.	APPLIES TO	MAJOR REV	COMMENT
O-RINGS, SERVICE SIDE, SMALL	199K0031	ALL COMPRESSORS	ALL	Includes O-rings for cooling valves, 6 Pin, 4 Pin, and 9 Pin Hermetic Feedthroughs
O-RING, SOLENOID ORIFICE	199K0030	ALL COMPRESSORS	ALL	Only replaces cooling valve O-rings

6.10 Compressor Cooling Cable and Coil Assembly

Kit Number 100063-1

Cable number: 710303

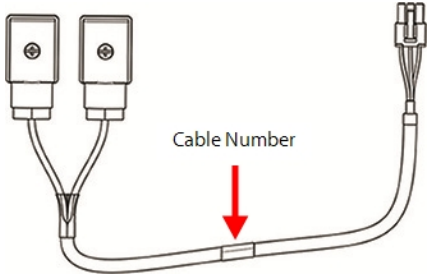

Kit Number 199K0026

Cable number: 600A0304

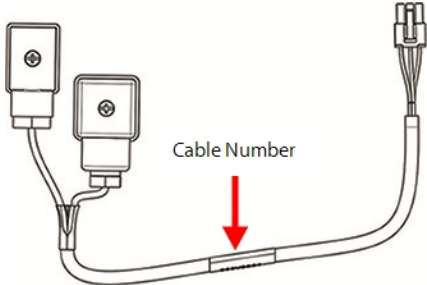

Kit Number 199K0077

Cable number: 600A0467

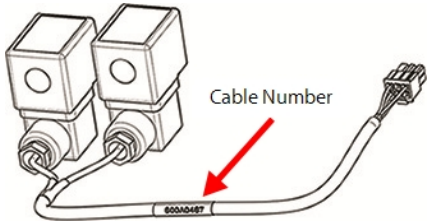

DESCRIPTION	PART NO.	APPLIES TO	MAJOR REV	COMMENT
COMPRESSOR COOLING CABLE/COIL ASSY	100063-1	ALL COMPRESSORS	ALL	Includes hardware Refer to Note below before purchasing!
COMPRESSOR COOLING CABLE/COIL ASSY	199K0026	<ul style="list-style-type: none"> TTS450/TGS650 TGS380 /TGS510 TTH375/TGH285 	-H, -J	Includes hardware The introduction of this new valve has been applied starting with the following compressors: <ul style="list-style-type: none"> TTH375 / TGH285 (S/N 2419950194 and later) TGS380 / TTS450 (S/N 2419950222 and later) Refer to Note below before purchasing!
COMPRESSOR COOLING CABLE/COIL ASSY	199K0077	<ul style="list-style-type: none"> TTS350 TGS310 TTH375/TGH285 	-J	Includes hardware Active Cooling Models Only



NOTE

In some cases, the Motor Cooling Solenoid for a compressor manufactured prior to the serial numbers defined may have been upgraded and therefore, verification of the correct replacement parts is necessary. Please refer to Customer Notification B-CN-370 for any additional information regarding the upgrade.

6.11 6-Pin Hermetic Feedthrough

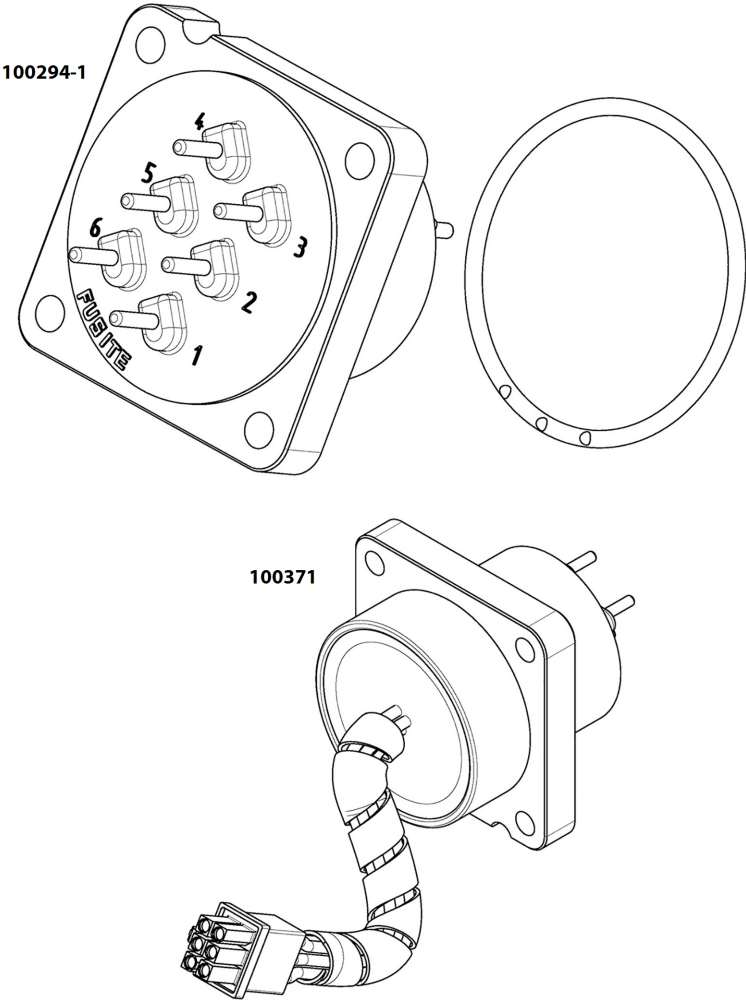

DESCRIPTION	PART NO.	APPLIES TO	MAJOR REV	COMMENT
FEEDTHROUGH, 6 PIN	100294-1	ALL COMPRESSORS	-N, -P, -A, -C, -D, -E	Includes O-ring and fasteners
FEEDTHROUGH, 6 PIN	100371	ALL COMPRESSORS	-F, -G, -H, -J	Includes O-ring and fasteners

6.12 Cavity Temperature Sensor/Motor Rotor

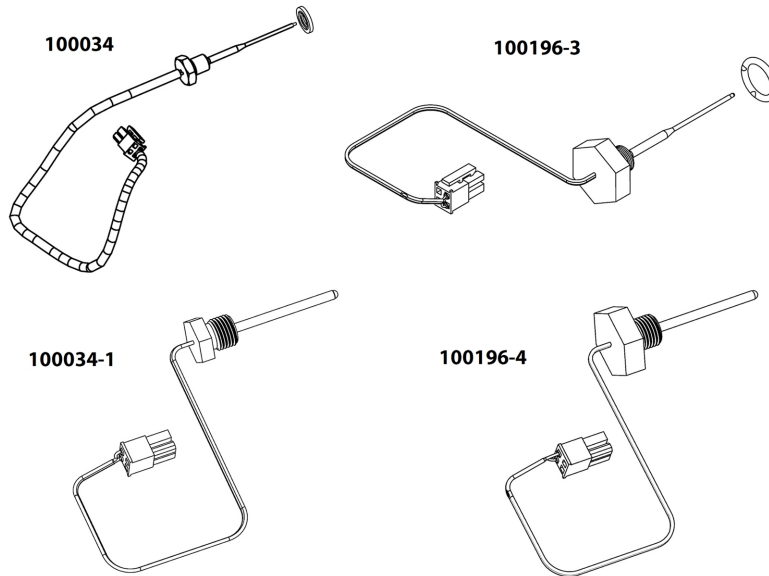

DESCRIPTION	PART NO.	APPLIES TO	MAJOR REV	COMMENT
CAVITY TEMP SENSOR	100034	<ul style="list-style-type: none"> TTS300/TTS350/TTS400 	-N, -P, -A, -C, -D	Do not use if compressor PN ends in "-3". Includes Sensor and Seal (16mm sensor head)
CAVITY TEMP SENSOR	100196-3	<ul style="list-style-type: none"> TTS300/TTS350/TTS400/TTS650/TTS450 TGS230/TGS310/TGS380/TGS390/TGS490/TGS510 TTH375/TGH285 	-E, -F, -G, -H, -J	Also use if compressor part number ends in "-3". Includes O-ring (15/16" sensor head)
CAVITY TEMP SENSOR	100034-1	<ul style="list-style-type: none"> TTS500 	-A	Do not use if compressor PN ends in "-3", Includes O-ring (16mm sensor head)
CAVITY TEMP SENSOR	100196-4	<ul style="list-style-type: none"> TTS500/TTS700 TGS520 	-E, -F, -G, -H	Also use if compressor part number ends in "-3". includes O-ring (15/16" sensor head)

6.13 4-Pin Hermetic Feedthrough

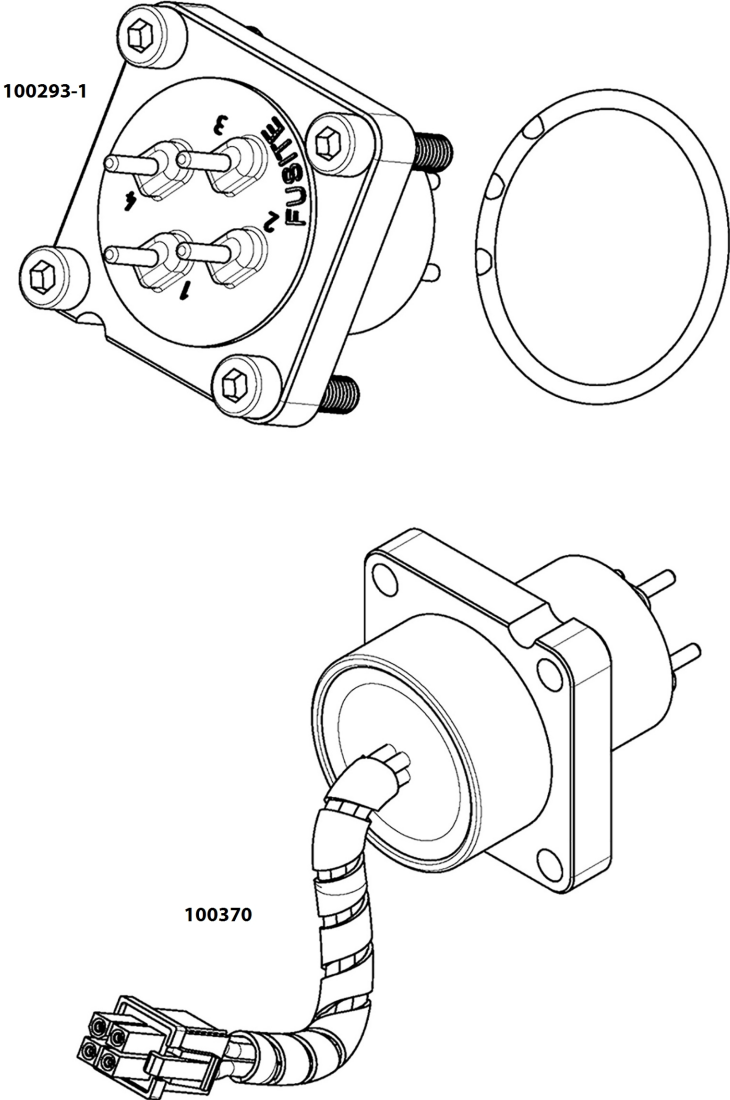

DESCRIPTION	PART NO.	APPLIES TO	MAJOR REV	COMMENT
FEEDTHROUGH, 4 PIN	100293-1	ALL COMPRESSORS	-N, -P, -A, -C, -D, -E	Includes O-ring and fasteners
FEEDTHROUGH, 4 PIN	100370	ALL COMPRESSORS	-F, -G, -H, -J	Includes O-ring and fasteners

6.14 9-Pin Hermetic Feedthrough

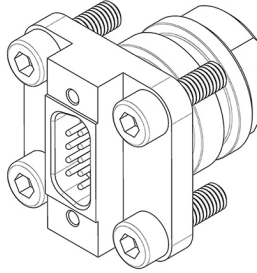

100295-1



199K0073

NOTE

The two Bearing Sensor Feedthroughs listed on this page are not interchangeable. Prior to Major Revision J, the feedthrough and the cable were separate. Beginning with Major Revision J compressors, the Bearing Sensor Feedthrough has an integrated cable and it connects directly to the Backplane. Prior to ordering the Bearing Sensor Feedthrough, verify the Major Revision of the compressor. If the compressor is Major Revision H or earlier, verify that the Bearing Sensor Feedthrough and Backplane have not been upgraded.

DESCRIPTION	PART NO.	APPLIES TO	MAJOR REV	COMMENT
FEEDTHROUGH, 9 PIN	100295-1	ALL COMPRESSORS	-N, -P, -A, -C, -D, -E, -F, -G, -H	Includes Feedthrough, O-rings, and fasteners
FEEDTHROUGH, 9 PIN	199K0073	<ul style="list-style-type: none"> TTS350/TTS650 TGS310/TGS510 TTH375/TGH285 	-J	Includes Feedthrough, O-rings, and fasteners
O-RINGS, FEEDTHROUGH, 9 PIN	199K0074	ALL COMPRESSORS	ALL	Includes fasteners and O-rings

6.15 Cooling Valves Assembly

This section contains the various kits related to the Cooling Valves.

- Cooling Valve kits contain two Plunger Assemblies, two Orifices for the Inverter and Motor Cavity ports, and the O-rings required for replacement.
- Solenoid Plunger and Harness Field Upgrade kit - An upgrade kit for TTH375/TGH285 & TGS380/TTS450 Major Revision H models.
- Orifice Body kits - Contains only the orifice and the two O-rings at the base of the orifice. *The Plunger Tube base O-ring must be purchased separately in kit 100K0030.*
- Plunger Assembly kits - include one plunger and internal seal (included seal cannot be ordered separately).

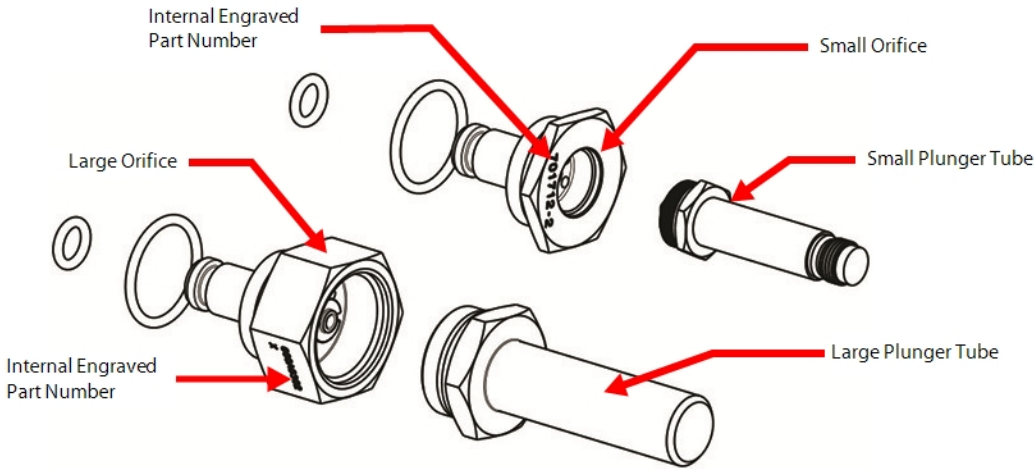

6.15.1 Cooling Valves Assembly

Refer to the following tables to select the proper Cooling Valve Assembly kit. Match the compressor model, major revision, application, and voltage of the compressor to determine the appropriate part number.

The table immediately below provides the kit part number, as well as the internal engraved number of the orifices included in the kits. The engraved number on the orifices can be used as a reference to identify what orifice is currently installed on the compressor. There are some instances where an upgrade kit has been installed. **Please continue to the next table to match the compressor model, major revision, application, and voltage of the compressor to determine the appropriate part number.**

Kit Description	Kit Part Number (with internal engraving numbers)
Cooling Valve Kit (2 orifices)	100281-2 (700802-3 / 700802-3)
Cooling Valve Kit (2 orifices)	100281-3 (701712-25 / 700802-6)
Cooling Valve Kit (2 orifices)	100281-4 (700802-6 / 700802-6)
Cooling Valve Kit (2 orifices)	100281-5 (701712-2 / 701712-25)
Cooling Valve Kit (2 orifices)	199K0029 (701712-2 / 600A0302)
Cooling Valve Kit (2 orifices)	199K0084 (600A0448 / 600A0302)

COOLING VALVE ASSEMBLY				
COMPRESSOR MODEL	MAJOR REVISION	APPLICATION	VOLTAGE	
			380V/400V/460V	575V
TGS230	ALL	ALL	100281-2	100281-2
TGS310	H and Lower	ALL	100281-1	100281-1
TGS310	J	Active Cooling	199K0029	199K0029
TGS380	ALL	ALL	100281-5 / 199K0029* *See note below*	100281-5 / 199K0029* *See note below*
TGS390	ALL	ALL	100281-4	100281-1
TGS490	ALL	ALL	100281-5	100281-5
TGS510	J	ALL	199K0029	199K0029
TGS520	ALL	ALL	100281-3	100281-3
TGH285	H and Lower	ALL	100281-5 / 199K0029* *See note below*	100281-5 / 199K0029* *See note below*
TGH285	J	Active Cooling	199K0084	199K0084
TTS300	ALL	ALL	100281-2	100281-2
TTS350	H and lower	ALL	100281-5	100281-5
TTS350	J	Active Cooling	199K0029	199K0029
TTS400	ALL	ALL	100281-4	100281-1
TTS450	H and Lower	ALL	100281-5 / 199K0029* *See note below*	100281-5 / 199K0029* *See note below*
TTS500	ALL	ALL	100281-3	100281-3
TTS650	J	ALL	199K0029	199K0029
TTS700	ALL	ALL	100281-3	100281-3
TTH375	H and Lower	ALL	100281-5 / 199K0029* *See note below*	100281-5 / 199K0029* *See note below*
TTH375	J	Active Cooling	199K0084	199K0084

*** The introduction of cooling valve 199K0027 has been applied starting with the following compressors:**

- TTH375 / TGH285 (S/N 2419950194 and later)
- TGS380 / TTS450 (S/N 2419950222 and later)

Refer to Note below before purchasing!

NOTE

In some cases, the Motor Cooling Solenoid for a compressor manufactured prior to the serial numbers defined may have been upgraded and therefore, verification of the correct replacement parts is necessary. Please refer to Customer Notification B-CN-370 for any additional information regarding the upgrade. **These kits only apply to the compressor models listed.**

6.15.2 Solenoid Plunger and Harness Field Upgrade Kit

If service is to be performed on an installed compressor which has not been upgraded, Danfoss LLC recommends upgrading the entire valve with the new kit as opposed to servicing with the previously available spare part kits. This would only apply when the service is being performed on the Motor Cooling Valve for TTH375/TGH285 & TGS380/TTS450 Major Revision H models.

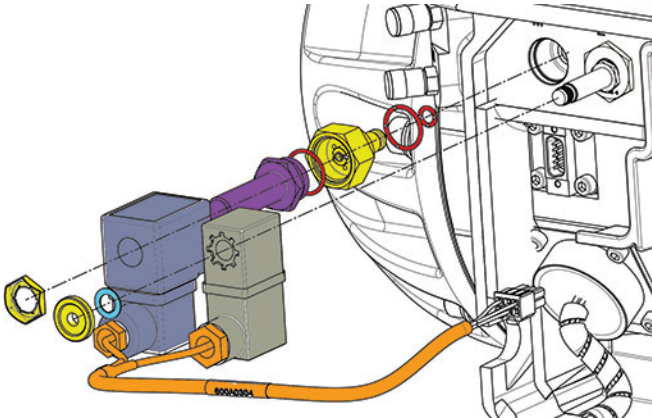

DESCRIPTION	PART NO.	APPLIES TO	MAJOR REV	COMMENT
SOLENOID PLUNGER-HARNESS FIELD REPLACEMENT	199K0025	<ul style="list-style-type: none"> TTS450 TGS380 TTH375/TGH285 	-H	Includes Motor Plunger, Orifice, Solenoid Coil/Harness Assy, O-rings, and hardware

6.15.3 Orifice Body

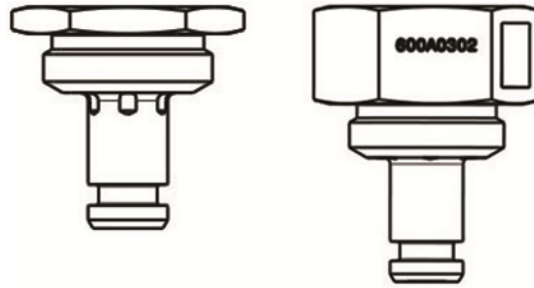

The table immediately below provides the kit part number, as well as the internal engraved number of the orifices included in the kits. The engraved number on the orifices can be used as a reference to identify what orifice is currently installed on the compressor. There are some instances where an upgrade kit has been installed. **Please continue to the next table to match the compressor model, major revision, application, and voltage of the compressor to determine the appropriate part number.**

Kit Description	Kit Part Number (with internal engraving numbers)
Orifice Body Kit	100236 (700802-3)
Orifice Body Kit	100238 (701712-25)
Orifice Body Kit	100239 (701712-2)
Orifice Body Kit	100240 (700802-6)
Orifice Body Kit	199K0027 (600A0302)
Orifice Body Kit	199K0083 (600A0448)

Refer to the following two tables to select the proper orifice. The first table contains the selection of the Motor Orifices and the second table contains the selection of Electronics Orifices. **Match the compressor model, major revision, application, and voltage of the compressor to determine the appropriate part number.** You will also need to purchase an O-ring set for each orifice kit. The part number for the O-ring set is 199K0030.

MOTOR SIDE ORIFICE BODY				
COMPRESSOR MODELS	MAJOR REVISION	APPLICATION	VOLTAGE	
			380V/400V/460V	575V
TGS230	ALL	ALL	100236	100236
TGS310	H and lower	ALL	100239	100239
TGS310	J	Active Cooling	199K0027	199K0027
TGS380	ALL	ALL	100238 / 199K0027 *See note below*	100238 / 199K0027 *See note below*
TGS390	ALL	ALL	100240	100239
TGS490	ALL	ALL	100238	100238
TGS510	J	ALL	199K0027	199K0027
TGS520	ALL	ALL	100238	100238
TGH285	H and lower	ALL	100238 / 199K0027 *See note below*	100238 / 199K0027 *See note below*

MOTOR SIDE ORIFICE BODY				
COMPRESSOR MODELS	MAJOR REVISION	APPLICATION	VOLTAGE	
			380V/400V460V	575V
TGH285	J	Active Cooling	199K0027	199K0027
TTS300	ALL	ALL	100236	100236
TTS350	H and lower	ALL	100238	100238
TTS350	J	Active Cooling	199K0027	199K0027
TTS400	ALL	ALL	100240	100239
TTS450	H and lower	ALL	100238 / 199K0027 *See note below*	100238 / 199K0027 *See note below*
TTS500	ALL	ALL	100238	100238
TTS650	J	ALL	199K0027	199K0027
TTS700	ALL	ALL	100238	100238
TTH375	H and lower	ALL	100238 / 199K0027 *See note below*	100238 / 199K0027 *See note below*
TTH375	J	Active Cooling	199K0027	199K0027

ELECTRONICS SIDE ORIFICE BODY				
COMPRESSOR MODELS	MAJOR REVISION	APPLICATION	VOLTAGE	
			380V/400V460V	575V
TGS230	ALL	ALL	100236	100236
TGS310	H and lower	ALL	100240	100240
TGS310	J	Active Cooling	100239	100239
TGS380	ALL	ALL	100239	100239
TGS390	ALL	ALL	100240	100240
TGS490	ALL	ALL	100239	100239
TGS510	J	ALL	100239	100239
TGS520	ALL	ALL	100240	100240
TGH285	H and lower	ALL	100239	100239
TGH285	J	Active Cooling	199K0083	199K0083
TTS300	ALL	ALL	100236	100236
TTS350	H and lower	ALL	100239	100239
TTS350	J	Active Cooling	100239	100239
TTS400	ALL	ALL	100239	100239
TTS450	H and lower	ALL	100239	100239
TTS500	ALL	ALL	100240	100240
TTS650	J	ALL	100239	100239
TTS700	All	ALL	100240	100240
TTH375	H and lower	ALL	100239	100239



ELECTRONICS SIDE ORIFICE BODY				
COMPRESSOR MODELS	MAJOR REVISION	APPLICATION	VOLTAGE	
			380V/400V460V	575V
TTH375	J	Active Cooling	199K0083	199K0083

NOTE

No O-ring included in the Orifice Body kits. **Part number 199K0030 (O-RING, SOLENOID ORIFICE) should be ordered with any orifice kit.**

- * The introduction of cooling valve 199K0027 has been applied starting with the following compressors:**
- TTH375 / TGH285 (S/N 2419950194 and later)
 - TGS380 / TTS450 (S/N 2419950222 and later)

Refer to Note below before purchasing!

NOTE

In some cases, the Motor Cooling Solenoid for a compressor manufactured prior to the serial numbers defined may have been upgraded and therefore, verification of the correct replacement parts is necessary. Please refer to Customer Notification B-CN-370 for any additional information regarding the upgrade. **These kits only apply to the compressor models listed.**

DESCRIPTION	PART NO.	APPLIES TO	MAJOR REV	COMMENT
O-RING, SOLENOID ORIFICE	199K0030	ALL COMPRESSORS	ALL	Order with any Orifice kit

6.15.4 Plunger Assembly

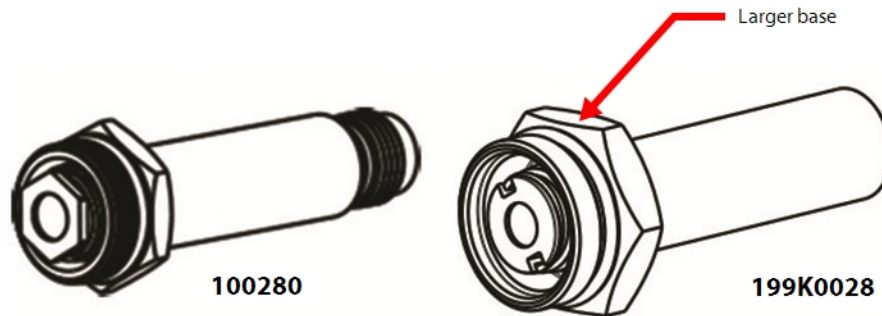

All kits include one plunger with hardware and O-ring.

It is always best to verify the installed cooling valves prior to purchase.

MOTOR SIDE PLUNGER ASSEMBLY				
COMPRESSOR MODELS	MAJOR REVISION	APPLICATION	PART NUMBER	COMMENT
TGS230	ALL	ALL	100280	For small plunger assembly
TGS310	H and lower	ALL	100280	For small plunger assembly
TGS310	J	Active Cooling	199K0028	For large plunger assembly
TGS380	ALL	ALL	100280 / 199K0028	Refer to Notes below before purchasing!
TGS390	ALL	ALL	100280	For small plunger assembly
TGS490	ALL	ALL	100280	For small plunger assembly
TGS510	J	ALL	199K0028	For large plunger assembly
TGS520	ALL	ALL	100280	For small plunger assembly
TGH285	H and lower	ALL	100280 / 199K0028	Refer to Notes below before purchasing!
TGH285	J	Active Cooling	199K0028	For large plunger assembly
TTS300	ALL	ALL	100280	For small plunger assembly
TTS350	H and lower	ALL	100280	For small plunger assembly
TTS350	J	Active Cooling	199K0028	For large plunger assembly
TTS400	ALL	ALL	100280	For small plunger assembly
TTS450	H and lower	ALL	100280 / 199K0028	Refer to Notes below before purchasing!
TTS500	ALL	ALL	100280	For small plunger assembly
TTS650	J	ALL	199K0028	For large plunger assembly
TTS700	ALL	ALL	100280	For small plunger assembly
TTH375	H and lower	ALL	100280 / 199K0028	Refer to Notes below before purchasing!
TTH375	J	Active Cooling	199K0028	For large plunger assembly

NOTE 1

The introduction of this new plunger assembly(199K0028) was applied starting with the following compressors:

- TTH375 / TGH285 (S/N 2419950194 and later)
- TGS380 / TTS450 (S/N 2419950222 and later)

NOTE 2

In some cases, the Motor Cooling Solenoid for a compressor manufactured prior to the serial numbers defined may have been upgraded and therefore, verification of the correct replacement parts is necessary. Please refer to Customer Notification B-CN-370 for any additional information regarding the upgrade.

ELECTRONICS SIDE PLUNGER ASSEMBLY

COMPRESSOR MODELS	MAJOR REVISION	APPLICATION	PART NUMBER	COMMENT
TGS230	ALL	ALL	100280	For small plunger assembly
TGS310	H and lower	ALL	100280	For small plunger assembly
TGS310	ALL	ALL	100280	For small plunger assembly Includes Active Cooling
TGS380	ALL	ALL	100280	For small plunger assembly
TGS390	ALL	ALL	100280	For small plunger assembly
TGS490	ALL	ALL	100280	For small plunger assembly
TGS510	J	ALL	100280	For small plunger assembly
TGS520	ALL	ALL	100280	For small plunger assembly
TGH285	H and lower	ALL	100280	For small plunger assembly
TGH285	J	Active Cooling	199K0028	For large plunger assembly
TTS300	ALL	ALL	100280	For small plunger assembly
TTS350	ALL	ALL	100280	For small plunger assembly
TTS400	ALL	ALL	100280	For small plunger assembly
TTS450	H and lower	ALL	100280	For small plunger assembly
TTS500	ALL	ALL	100280	For small plunger assembly
TTS650	J	ALL	100280	For small plunger assembly
TTS700	All	ALL	100280	For small plunger assembly
TTH375	H and lower	ALL	100280	For small plunger assembly
TTH375	J	Active Cooling	199K0028	For large plunger assembly

6.16 Pressure Regulating Valve

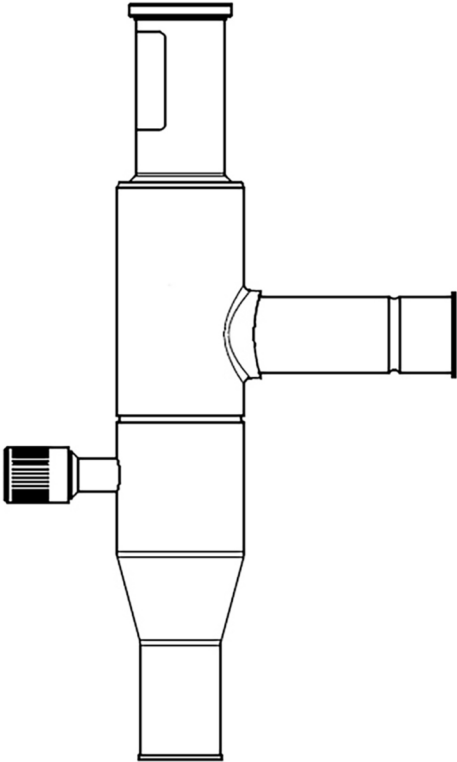

DESCRIPTION	PART NO.	APPLIES TO	MAJOR REV	COMMENT
KVP 22 EVAPORATOR PRES REG M/12	034L0025	<ul style="list-style-type: none"> TTS300/TGS230 MEDIUM TEMP 	ALL	KVP 22, Inlet size [mm]: 22.00, Inlet connection type: SOLDER, ODF, Outlet size [mm]: 22.00, Outlet connection type: SOLDER, ODF

THIS PAGE INTENTIONALLY LEFT BLANK

Appendix A Test Equipment

A.1 DC Bus Test Harness

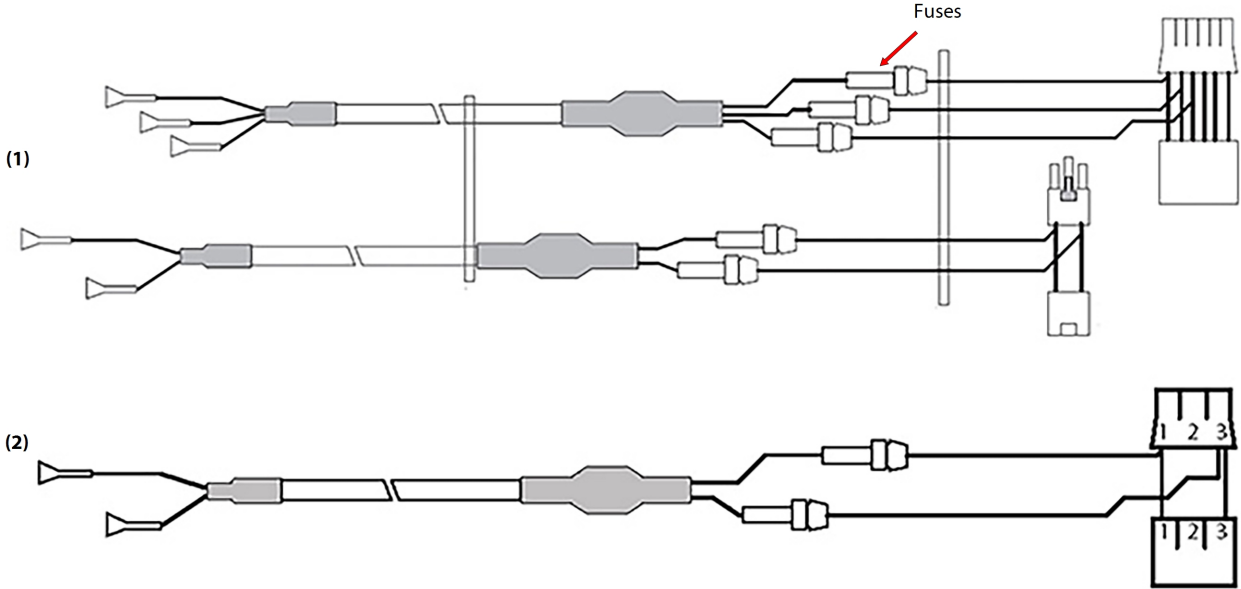

DESCRIPTION	PART NO.	APPLIES TO	MAJOR REV	COMMENT
(1) DC BUS TEST HARNESS	100326	ALL COMPRESSORS	-N, -P, -A, -C, -D, -E, -F, -G	Cable Only
(2) DC BUS TEST HARNESS	100101	ALL COMPRESSORS	-H, -J (including 200193 and 200095 Soft Starts)	Cable Only

A.2 Compact Inverter Tester

The Compact Inverter Tester allows users to verify the inverter is correctly functioning, and to verify the functionality of the inverter control card. Testing can be accomplished without the removal of the inverter assembly.

The Compact Inverter Tester provides all power necessary to interface with the inverter module during testing. This device will test the high voltage section, both top and bottom diodes of each section, and the driver board of the inverter.

DESCRIPTION	PART NO.	APPLIES TO	MAJOR REV	COMMENT
COMPACT INVERTER TESTER	100377	ALL COMPRESSORS	ALL	Includes power adapter, AC plug (US and Europe), data cables, and user manual



THIS PAGE INTENTIONALLY LEFT BLANK

Appendix B Accessory Kits

B.1 I/O Board Assembly

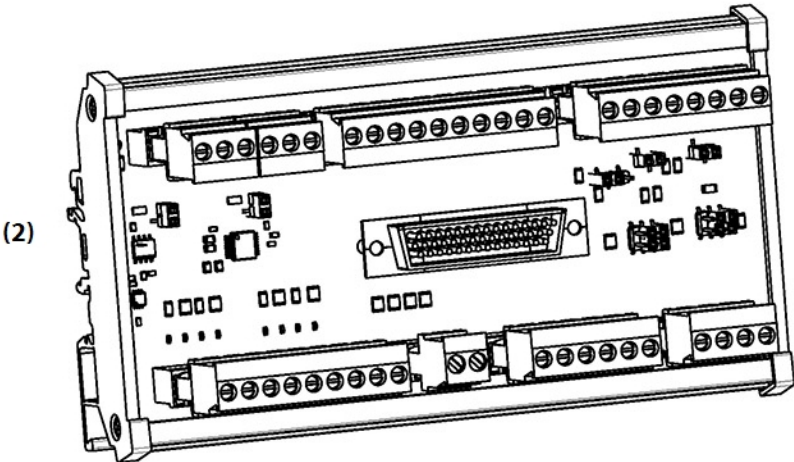
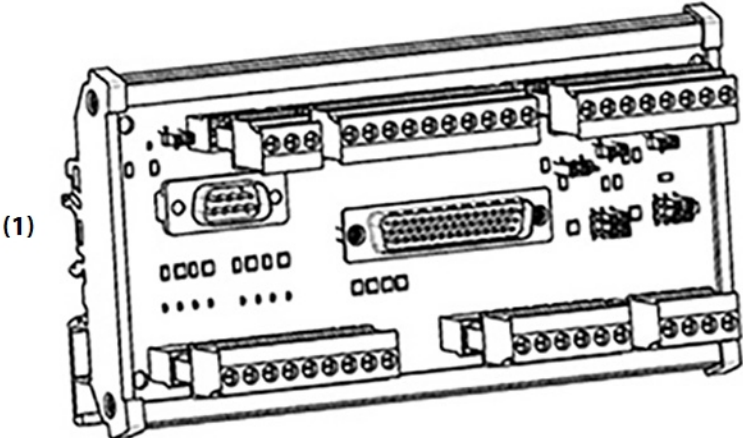

DESCRIPTION	PART NO.	APPLIES TO	MAJOR REV	COMMENT
(1) I/O BOARD ASSY	100076-1	ALL COMPRESSORS	ALL	PCB Assembly Only
(2) I/O BOARD ASSY RS485-X2	100410	ALL COMPRESSORS	ALL	Used for TurbocorCloud® Gateway

B.2 Compressor Interface Cable

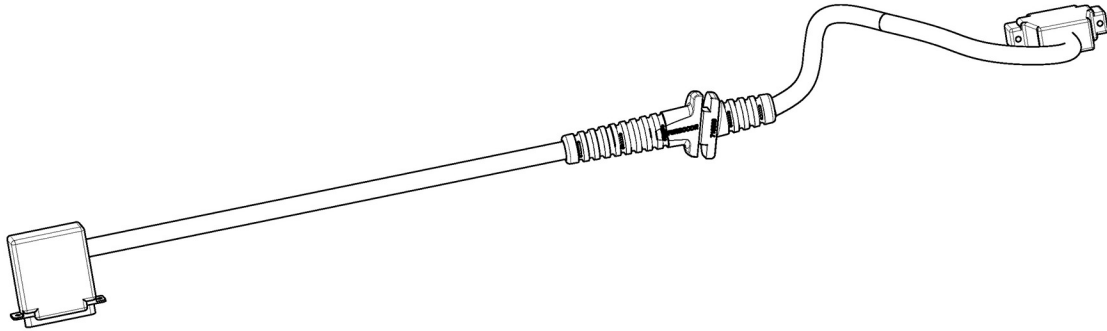

DESCRIPTION	PART NO.	APPLIES	MAJOR REV	COMMENT
COMPRESSOR INTERFACE CABLE, 5M	100058-1	ALL COMPRESSORS	ALL	Cable Only
COMPRESSOR INTERFACE CABLE, 10M	100058-4	ALL COMPRESSORS	ALL	Cable Only
COMPRESSOR INTERFACE CABLE, 20M	100058-5	ALL COMPRESSORS	ALL	Cable Only (See Note below)

NOTE

Compressor Interface Cables longer than 10m (32.8 ft) of total length exceed the maximum recommended length and could lead to inconsistent and unreliable performance on communication and stepper motor interfaces. It is recommended to consult DTC Product Support to see if the 20m is appropriate for your application.

B.3 Rubber Mounts

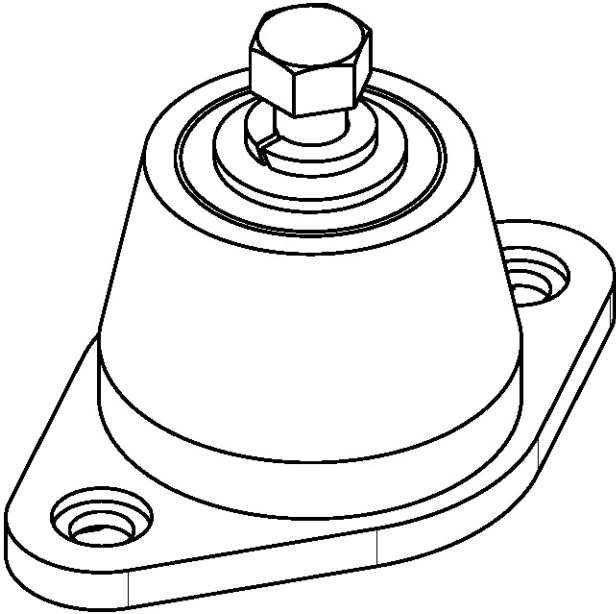

DESCRIPTION	PART NO.	APPLIES TO	MAJOR REV	COMMENT
RUBBER MOUNT	100066	ALL COMPRESSORS	ALL	Includes fasteners and washers for mounting compressor to the mount. Rubber mount to chiller fasteners are not included.

Neoprene mountings shall have a maximum static deflection of 0.4" (10mm). All metal surfaces shall be neoprene covered and have friction pads at the bottom. Bolt holes shall be provided on the bottom and a tapped hole and cap screw on top. Aluminum rails shall be used above the mountings under the compressor such as small vent sets to compensate for the overhang.

- Maximum Deflection: 10mm (0.4")
- Material: Neoprene Duro Meter 50
- Tightening Torque: 14 ± 3 Nm (10 ± 4 ft.lb.)
- Capacity Range: 50 -107 kg (110 - 235 lb.) EACH

B.4 End Cap Insulation

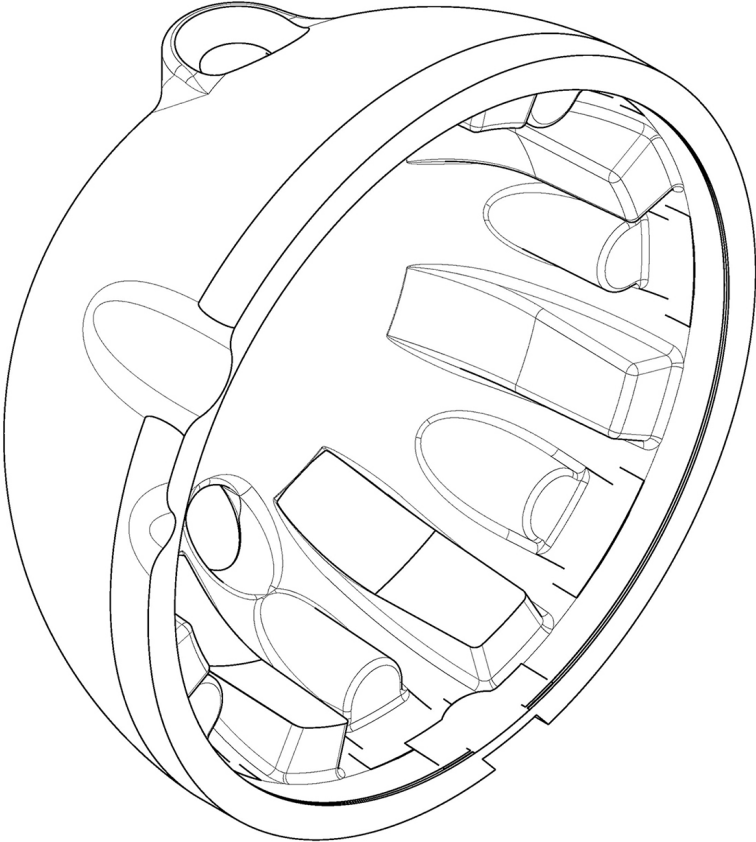

DESCRIPTION	PART NO.	APPLIES TO	MAJOR REV	COMMENT
END CAP INSULATION	100147	ALL COMPRESSORS (Except TTH375/TGH285)	ALL	Includes end cap insulation and silicone adhesive. (Does not apply to TTH375/TGH285 compressors)

The End Bell Kit insulates the compressor's end bell to prevent condensation due to the motor-cooling circuit located on this end of the compressor.

- Size: 11 1/2" diameter
- Flame Class: HF-1
- Compatible with all compressor models
- UL approved
- Material: Polystyrene Grade 54

B.5 EMI/EMC Filters

The Interference/Electromagnetic Compatibility (EMI/EMC) Filter minimizes harmonics in the higher frequency domain (typically above 1kHz). In order for the compressor to be CE-compliant, it should be located between the disconnect switch and the line reactor.

DESCRIPTION	PART NO.	APPLIES TO	MAJOR REV	COMMENT
EMI/EMC FILTER 322A, CE	901866	ALL COMPRESSORS	ALL	Filter only

Specifications

- Approved to UL 1283
- Max leakage current each line to ground:
 - 90mA @ 250VAC 60Hz
 - 180mA @ 480VAC 60Hz
- Designed to comply to EN 133200. CSA 22.2 No. 8
- Hi Pot (1 Min)
- L/G 2210VDC
- L/L 2780VDC
- Rated voltage: up to 480VAC max 50/60Hz (3 Phase)
- Hi Pot (1 Min)
- A-G, B-G, C-G (3 tests)
- A-B, B-C, A-C (3 tests)
- Rated current:
 - 322A @ 40°C operating ambient temp
- Humidity range: 0-95% R.H.
- Power dissipation @ rated current: 30W max
- Weight: 35 lbs. max



EMI/ECI Filters (continued)

901866

NOTE: Torque wire lugs to 150 LB-IN

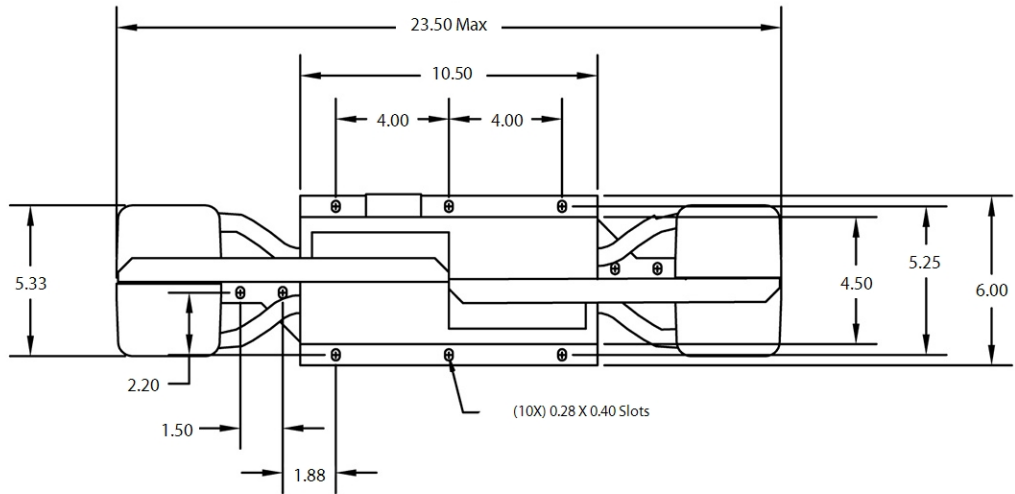

One AWG 6-250 MCM connection for ground.

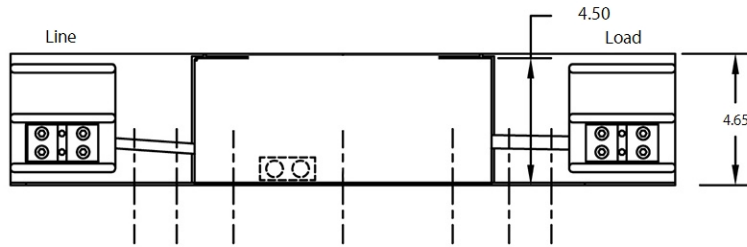
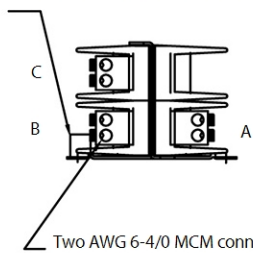

B.6 Line Reactors

The line reactor acts as an input buffer between the motor drive power circuits and the AC line power. Line reactors provide additional circuit impedance that improves power factor, reduces line current harmonics, and dampens the transient voltages on the power line, thereby protecting the electronic motor drive components.

DESCRIPTION	PART NO.	APPLIES TO	MAJOR REV	COMMENT
LINE REACTOR 240A - 5%	901832	ALL COMPRESSORS	ALL	Line Reactor only

Specifications

Ambient Temperature Max: 40°C (104°F)

Type: dry, air-cooled, open terminals

Flux density @ rated current: <1.6 tesla

Agency approvals:

Manufactured to UL Standard 508

UL recognized to file # E116124

CSA certified - LR86011

CE marked

Core type: high permeability silicon, non-grain-oriented (N.G.O.), laminated core

Phase/Frequency: 3-phase/ 50/60 Hz

Cooling type: air-cooled

Supply voltage: up to 480Vac (600 Max).

Q factor at rated current, 60 Hz: approx. 22

Rated current: 240A - 5%

Insulation class: Class H - 220

Inductance: 0.50mH \pm 10%

Dielectric strength tested @: 2.2kVac for 1 minute according to UL508

Total losses, basic current: approx. 500 W

Temp rise @ rated current: <155°C (<279°F)

Dimensions: 229H x 279W x 236D (in mm) 9H x 11W x 9.3D (in inches)

Mass: 43 kg (95 lbs.)

Impregnation: dip and bake process to varnish, class H insulation standard

Terminals: copper bus bar, hole to suit M8 bolt

NOTE

Failure to install a line reactor will result in a higher-than-rated current draw, larger cabling requirements, and lower power factor.

Line Reactors (continued)

901832

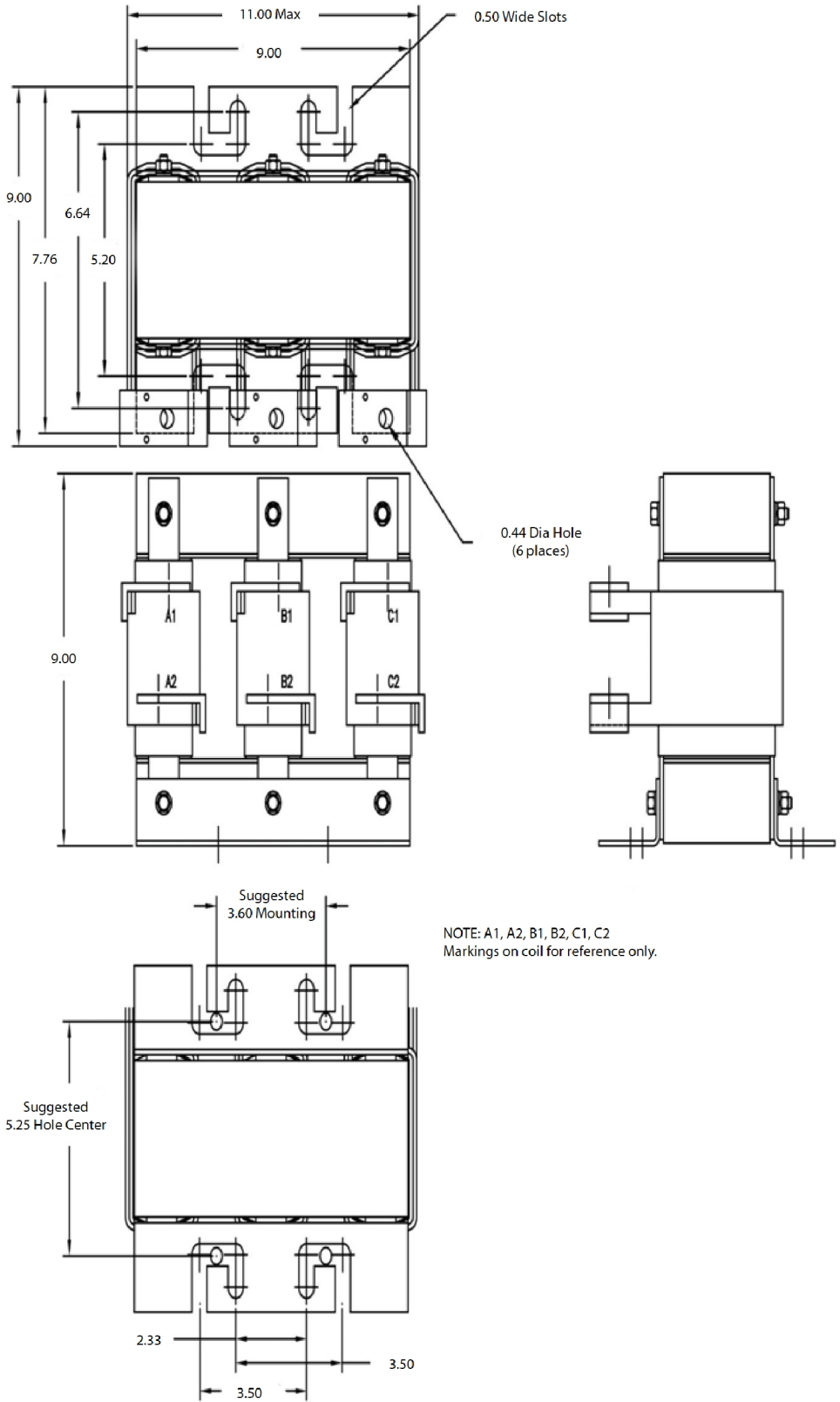

B.7 Flanges

Suction Flange

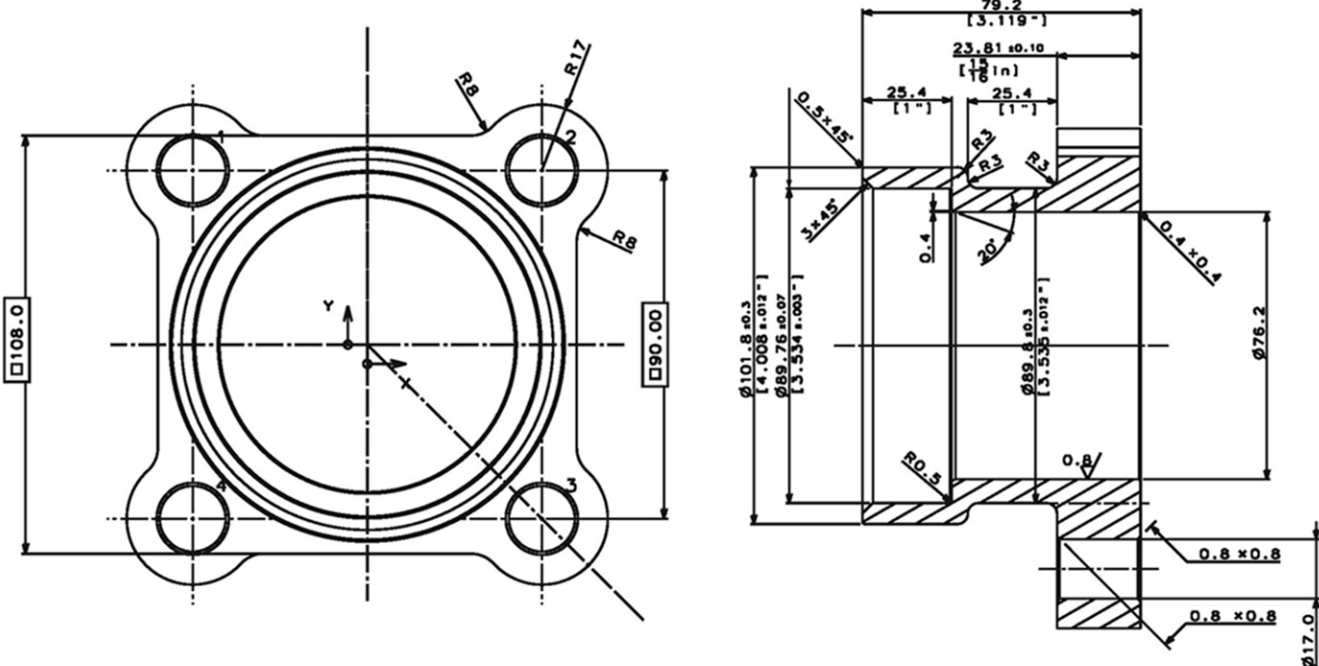

DESCRIPTION	PART NO.	APPLIES TO	MAJOR REV	COMMENT
SUCTION FLANGE, STEEL, 3 IN	100151-1	<ul style="list-style-type: none"> TTS300/TTS350/TTS400/TTS450 TGS230/TGS310/TGS380/TGS390/TGS490 TTH375/TGH285 	ALL	Includes flange, fasteners, and O-ring

Suction Flange (continued)

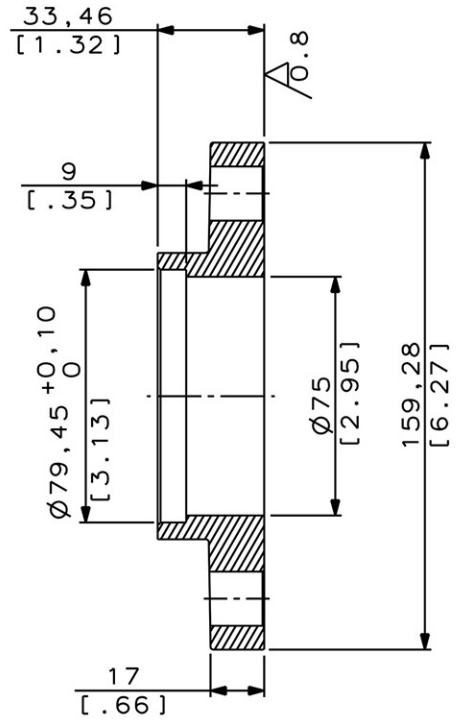
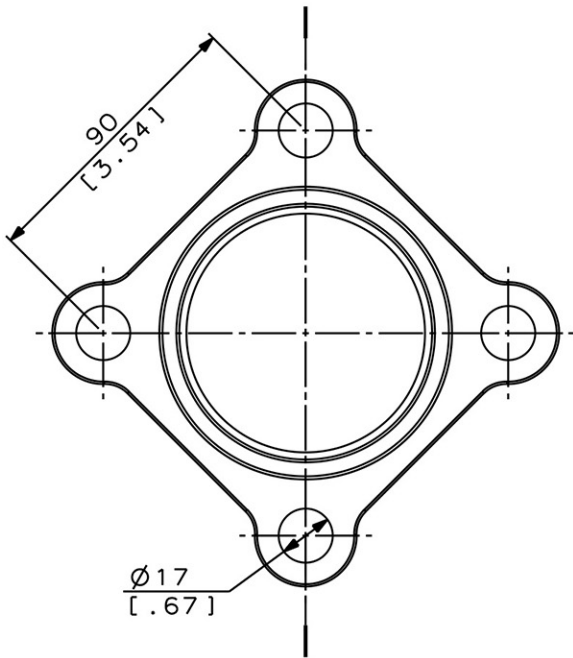

DESCRIPTION	PART NO.	APPLIES TO	MAJOR REV	COMMENT
SUCTION FLANGE, BRASS, 3 IN	100402-1	<ul style="list-style-type: none"> TTS300/TTS350/TTS400/TTS450 TGS230/TGS310/TGS380/TGS390/TGS490 TTH375/TGH285 	ALL	Includes flange, fasteners, and O-ring

Suction Flange (continued)

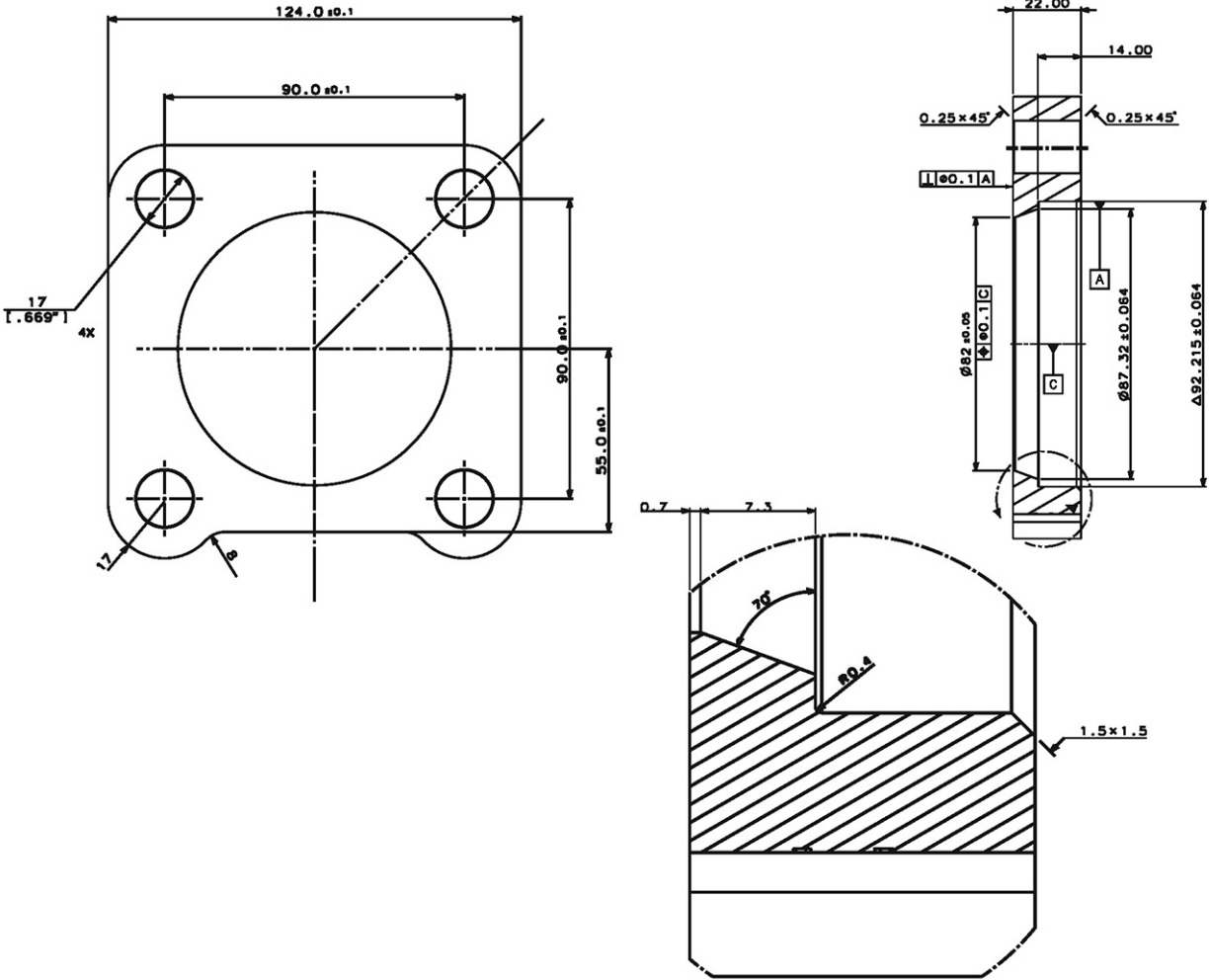

DESCRIPTION	PART NO.	APPLIES TO	MAJOR REV	COMMENT
SUCTION FLANGE, BRASS, 3-5/8 IN	100378	<ul style="list-style-type: none"> TTS500/TTS650/TTS700 TGS510/TGS520 	ALL	Includes flange, fasteners, and O-ring

Discharge Flange

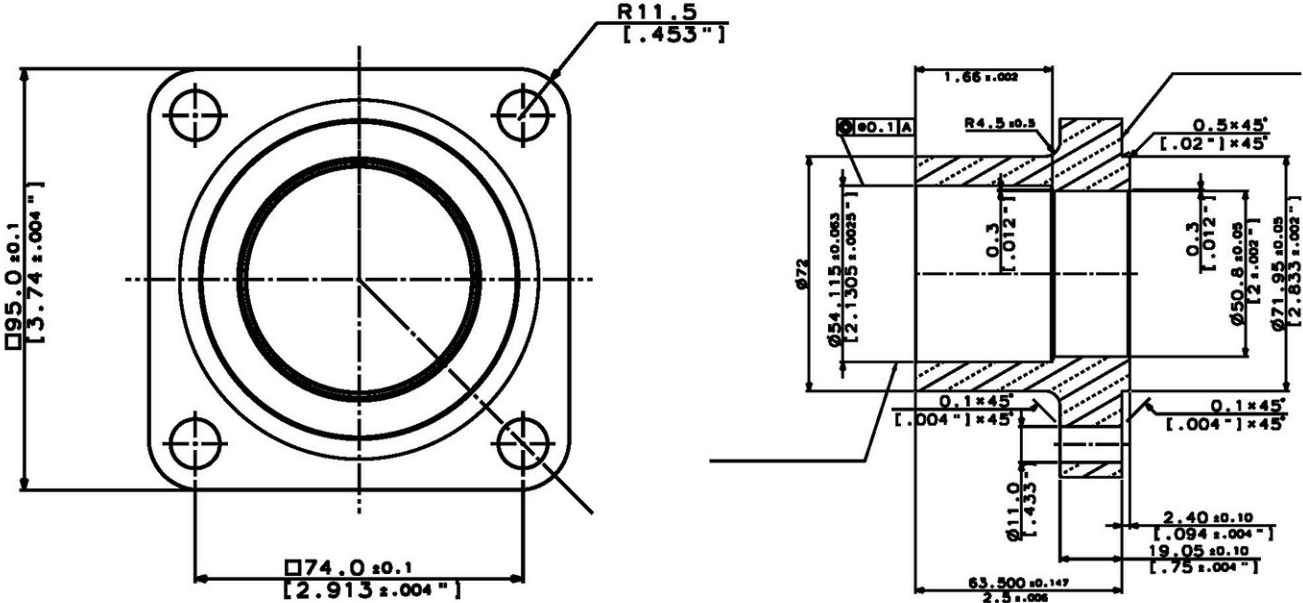

DESCRIPTION	PART NO.	APPLIES TO	MAJOR REV	COMMENT
DISCHARGE FLANGE, BRASS, 2-1/8 IN	100152	<ul style="list-style-type: none"> TTS300/TTS350/TTS400/TTS450 TGS230/TGS310/TGS380/TGS390 TTH375/TGH285 	ALL	Includes flange, fasteners, and O-ring

Discharge Flange (continued)

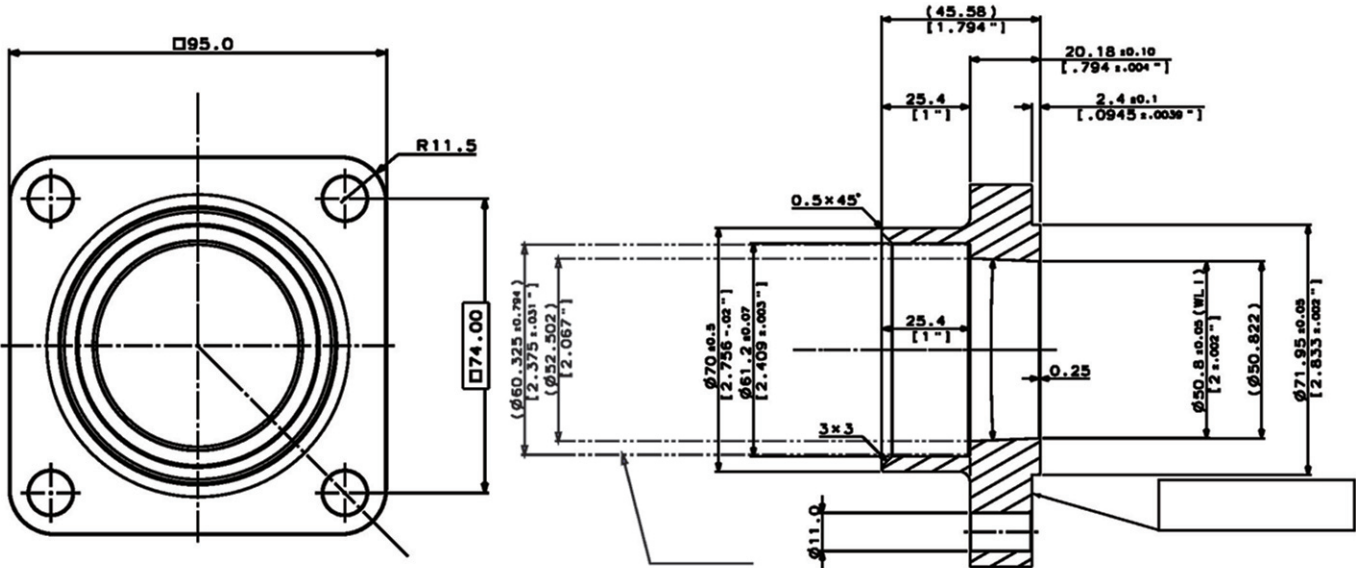

DESCRIPTION	PART NO.	APPLIES TO	MAJOR REV	COMMENT
DISCHARGE FLANGE, STEEL, 2-1/8 IN	100153-1	<ul style="list-style-type: none"> TTS300/TTS350/TTS400/TTS450 TGS230/TGS310/TGS380/TGS390 TTH375/TGH285 	ALL	Includes flange, fasteners, and O-ring

Discharge Flange (continued)

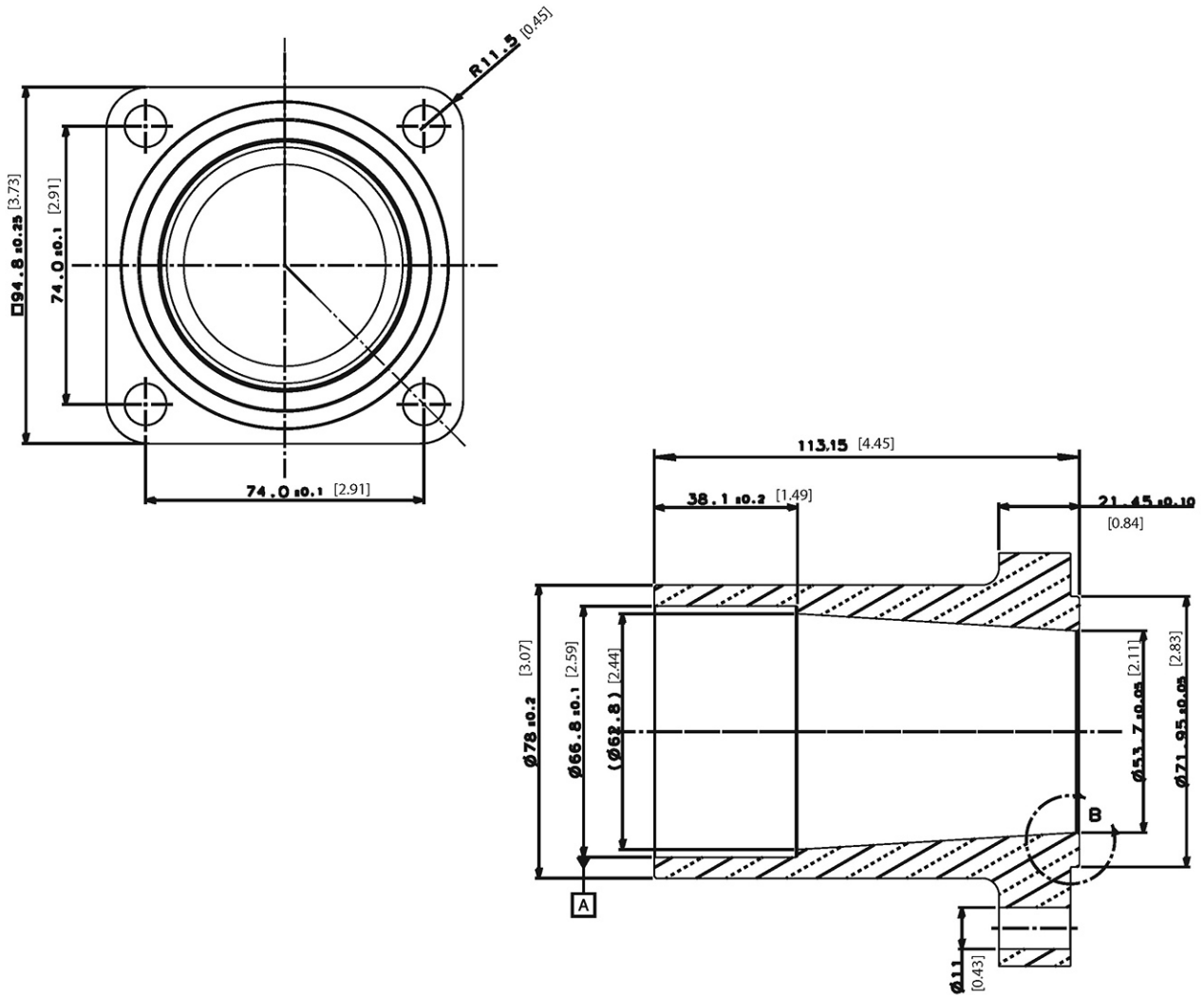

DESCRIPTION	PART NO.	APPLIES TO	MAJOR REV	COMMENT
DISCHARGE FLANGE, BRASS, 2-5/8 IN	100254	<ul style="list-style-type: none"> TTS500/TTS700 TGS490/TGS520 	ALL	Includes flange, fasteners, and O-ring

Discharge Flange (continued)

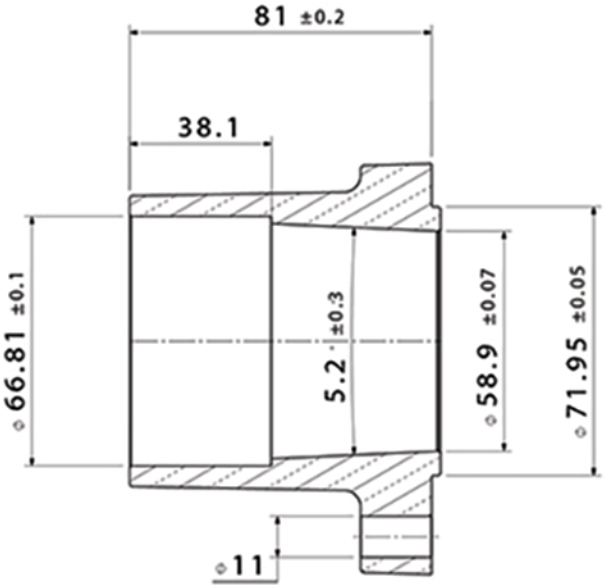
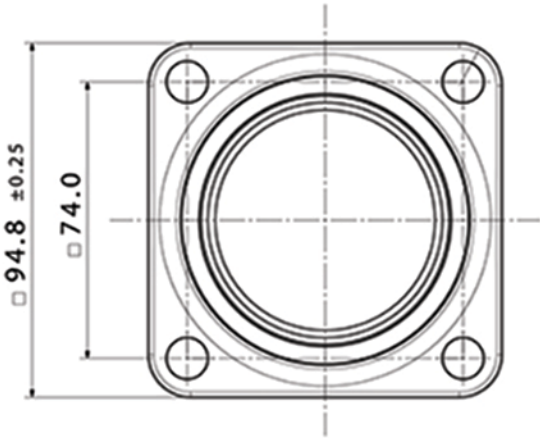

DESCRIPTION	PART NO.	APPLIES TO	MAJOR REV	COMMENT
DISCHARGE FLANGE, BRASS, 2-5/8 IN	199K0022	<ul style="list-style-type: none"> TTS650 TGS510 	-J	Includes flange, fasteners, and O-ring

Economizer Flange

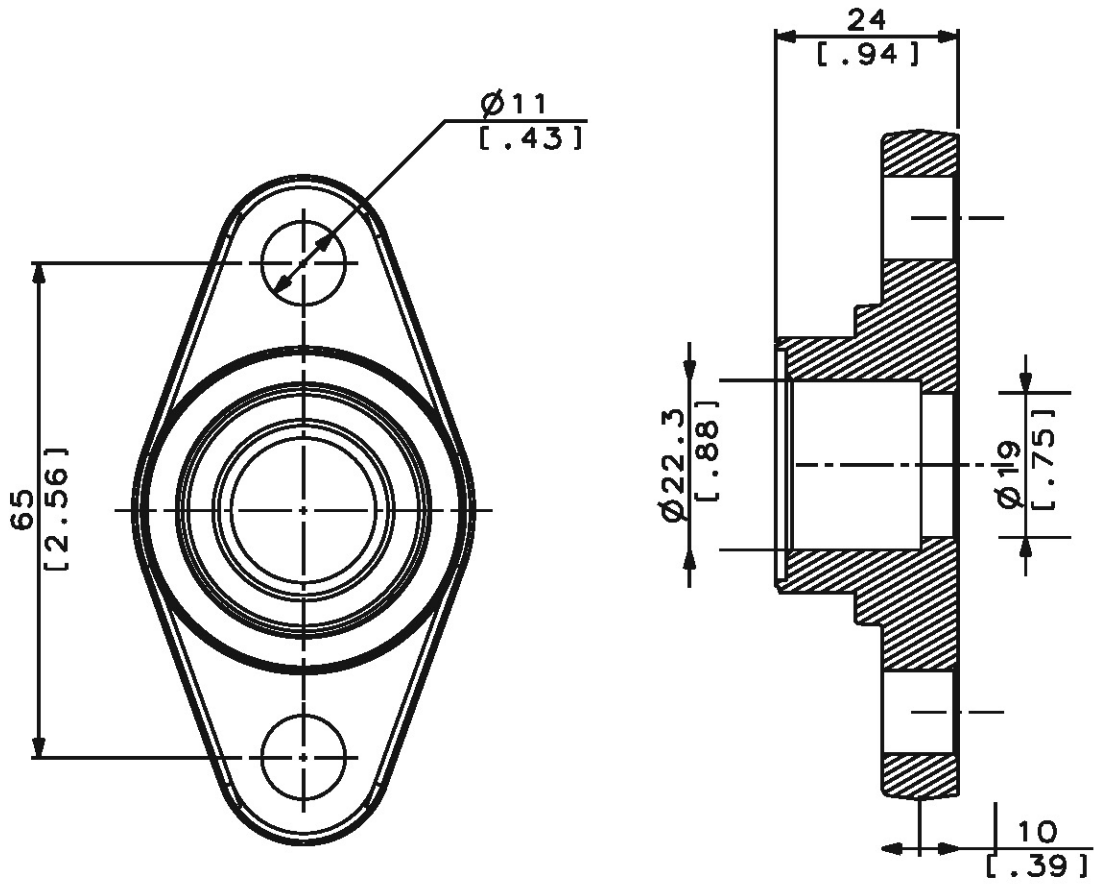

DESCRIPTION	PART NO.	APPLIES TO	MAJOR REV	COMMENT
ECONOMIZER FLANGE, BRASS, 7/8 IN	100400	<ul style="list-style-type: none"> TTS300/TGS230 	ALL	Includes flange, fasteners, and O-ring

Economizer Flange (continued)

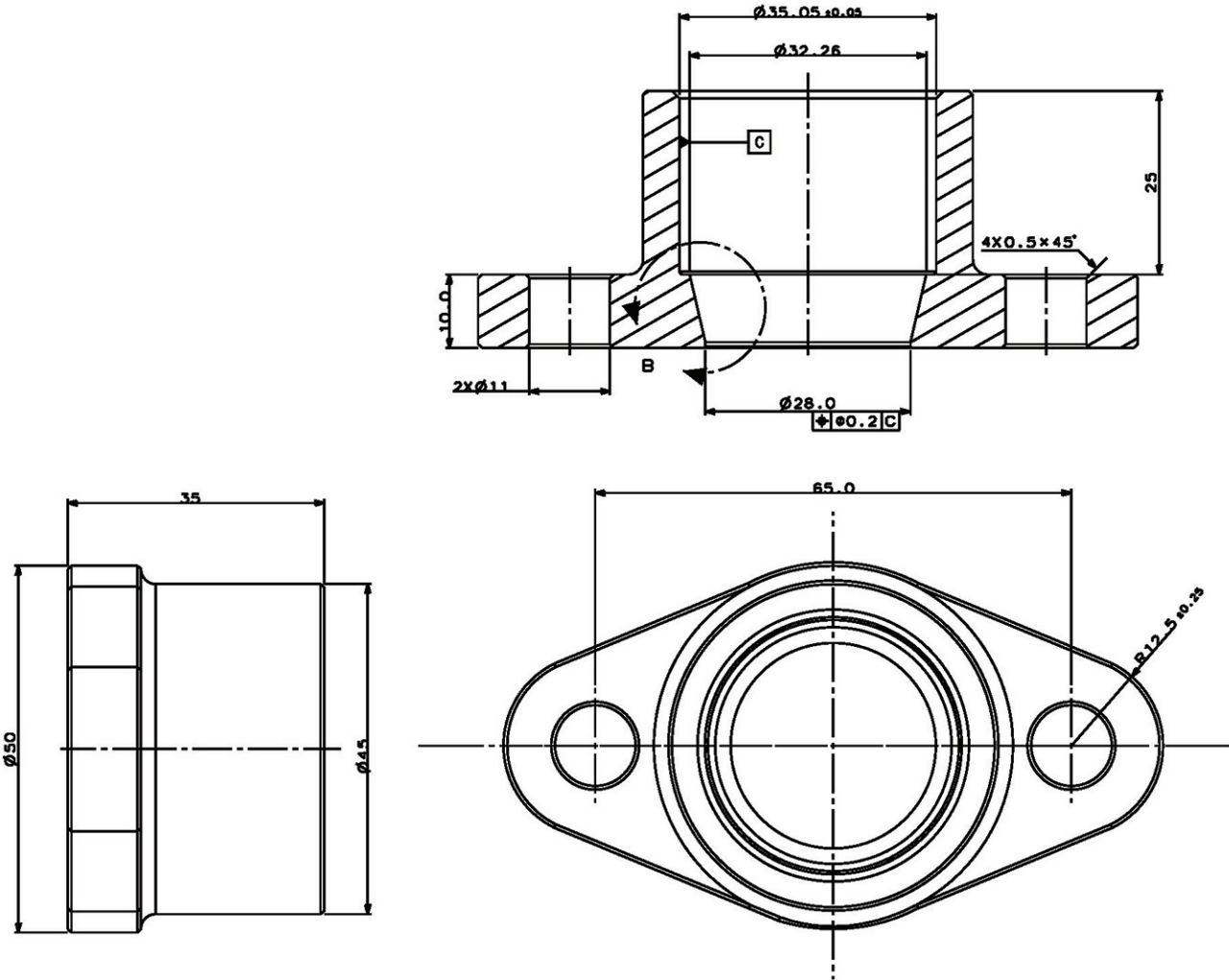

DESCRIPTION	PART NO.	APPLIES TO	MAJOR REV	COMMENT
ECONOMIZER FLANGE, BRASS, 1-3/8 IN	100450-1	<ul style="list-style-type: none"> TTS350/TTS400/TTS450/TTS500/TTS650/TTS700 TGS310/TGS380/TGS390/TGS490/TGS510/TGS520 TTH375/TGH285 	ALL	Includes flange, fasteners, and O-ring



THIS PAGE INTENTIONALLY LEFT BLANK

Appendix C TurbocorCloud® Kits

C.1 TurbocorCloud Gateway

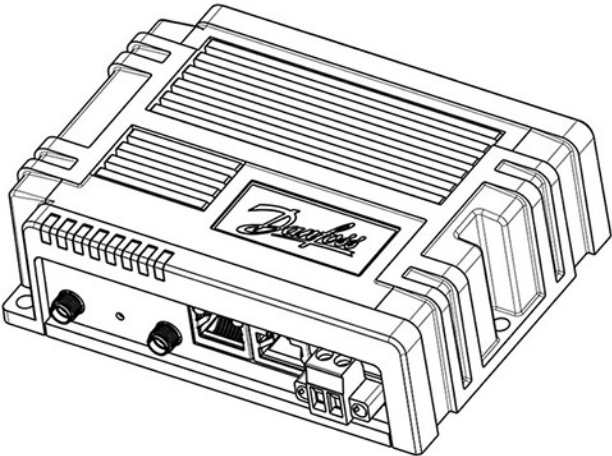

NOTE	
<p>Operation of the TurbocorCloud Gateway will require the following:</p> <ul style="list-style-type: none"> SIM Card when connecting to the cellular network (must use P/N 100476) Antenna to connect to the cellular network Communication cables (locally sourced, site specific) <p>Refer to the TurbocorCloud Installation and Commissioning Manual for the required components for operation.</p>	

DESCRIPTION	PART NO.	MAJOR REV	COMMENT
TurbocorCloud GATEWAY	100471	ALL	Includes TurbocorCloud Gateway and mounting clip only

C.3 Antenna

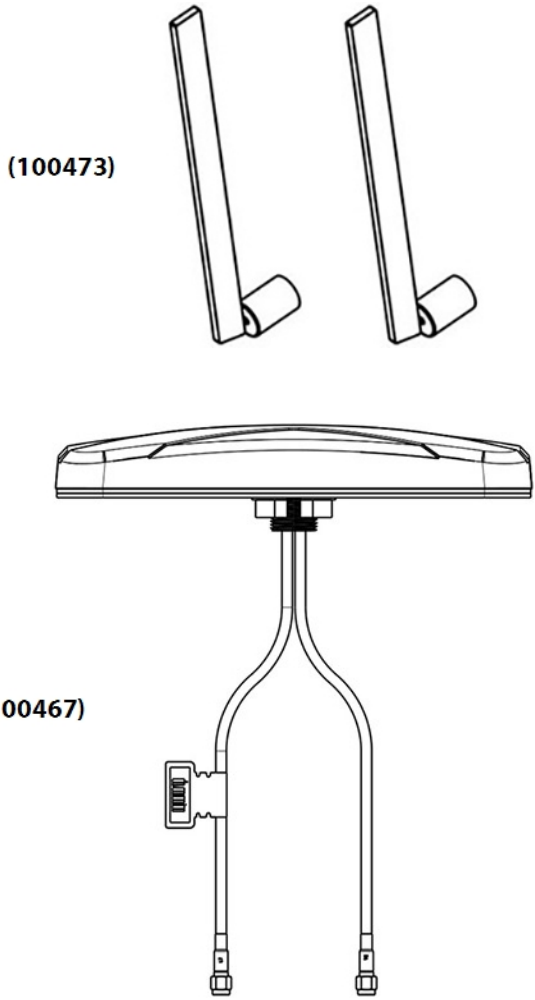

DESCRIPTION	PART NO.	MAJOR REV	COMMENT
(1) TurbocorCloud DIRECT CONNECT ANTENNA	100473	ALL	Includes two antennas
(2) TurbocorCloud EXT. ANTENNA	100467	ALL	Includes antenna only

THIS PAGE INTENTIONALLY LEFT BLANK

Appendix D Resonator

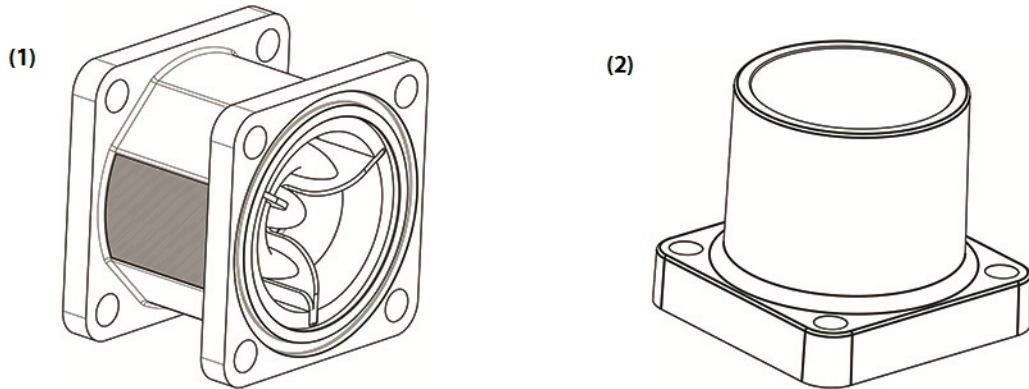

NOTE

- The Resonator is designed for use with low density HFO-1234ze and R515B refrigerant only.
- Refer to the following two pages for the dimensional drawings for the Resonator and Flange.

DESCRIPTION	PART NO.	APPLIES TO	MAJOR REV	COMMENT
RESONATOR+ HARDWARE	199K0004	<ul style="list-style-type: none"> • TGS230/TGS310/TGS380/TGS390/TGS490/TGS520 • TGH285 	ALL	Includes Resonator, O-rings, and fasteners
DISCHARGE FLANGE, BRASS (FOR RESONATOR USE)	199K0017	<ul style="list-style-type: none"> • TGS230/TGS310/TGS380/TGS390/TGS490/TGS520 • TGH285 	ALL	Includes Flange, O-rings, and fasteners Used in combination with the Resonator
RESONATOR, NO HARDWARE	199K0032	<ul style="list-style-type: none"> • TGS230/TGS310/TGS380/TGS390/TGS490/TGS520 • TGH285 	ALL	Includes Resonator and O-rings Fasteners and hardware not included
HARDWARE (FOR RESONATOR/DISCHARGE FLANGE)	199K0016	<ul style="list-style-type: none"> • TGS230/TGS310/TGS380/TGS390/TGS490/TGS520 • TGH285 	ALL	Includes O-rings and fasteners

Resonator Dimensional Drawing

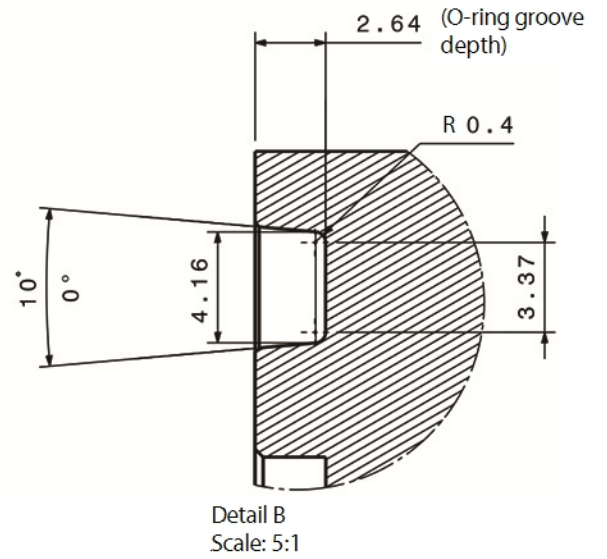
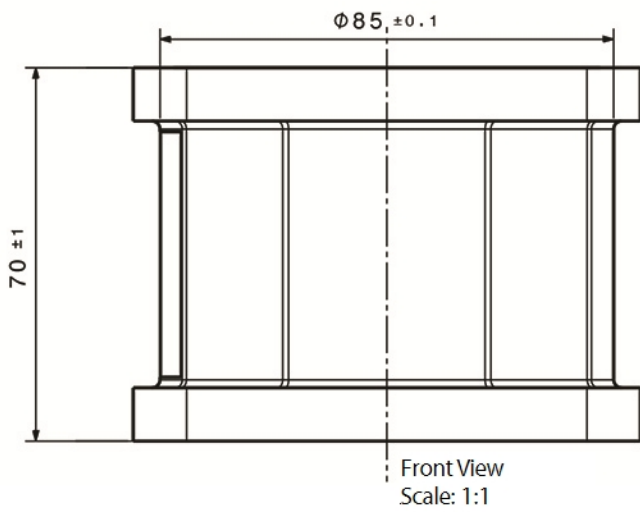
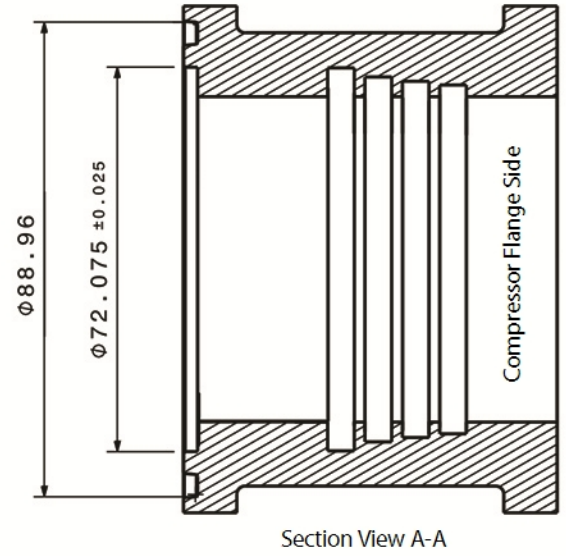
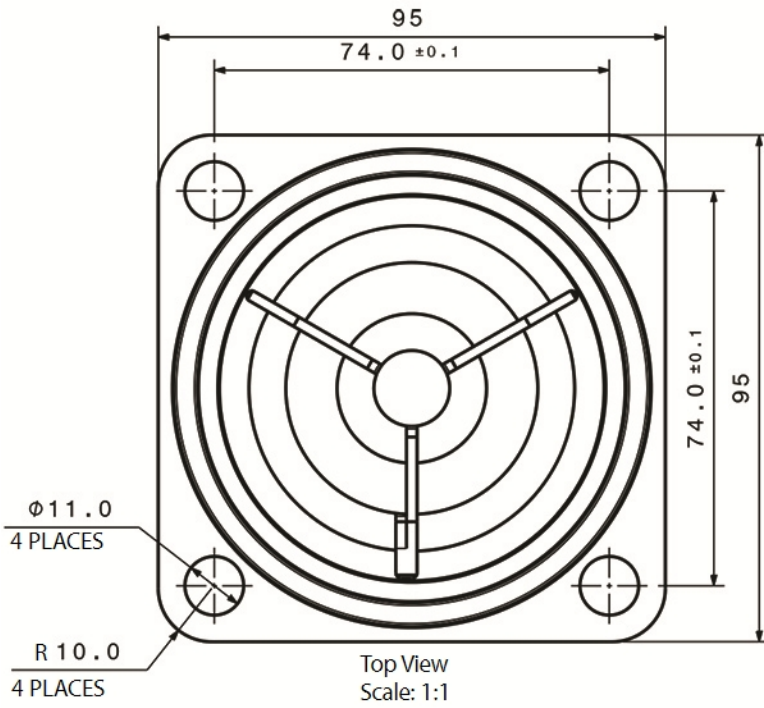

Flange Dimensional Drawing

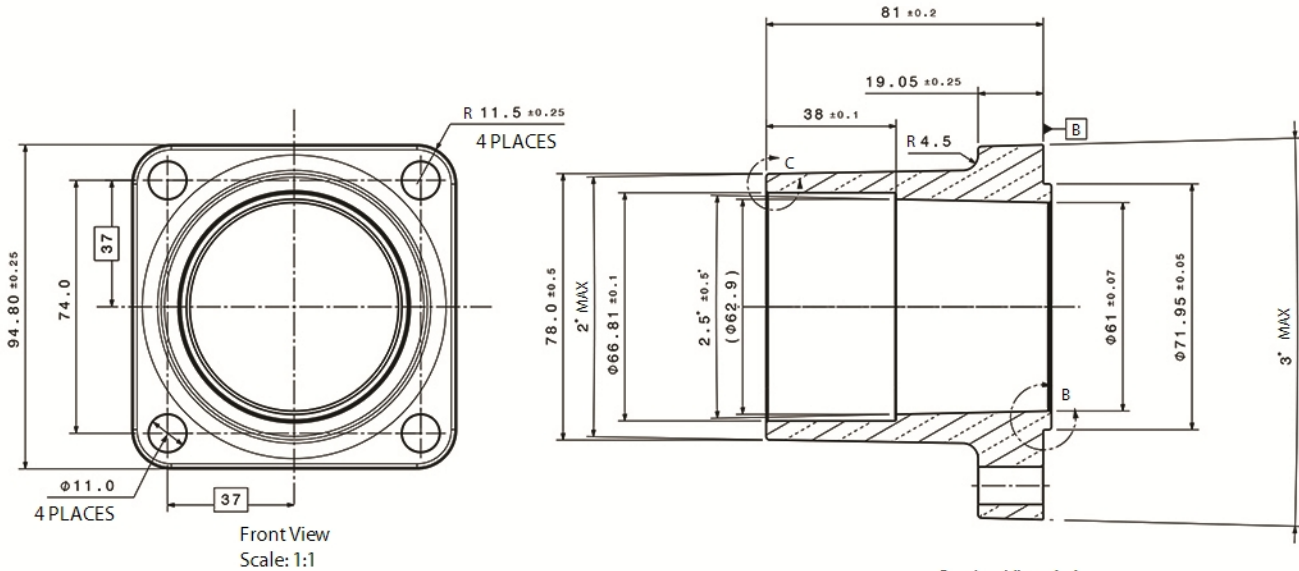

Front View
Scale: 1:1

Section View A-A
Scale: 1:1

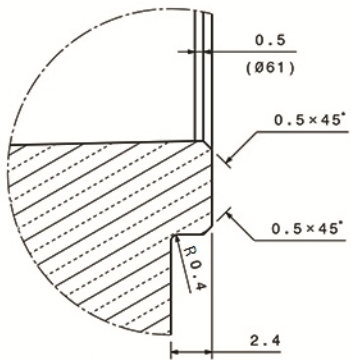

Detail B
Scale: 5:1

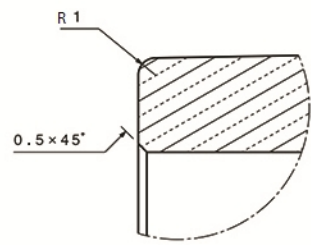

Detail C
Scale: 5:1



THIS PAGE INTENTIONALLY LEFT BLANK

Appendix E Obsolete Kit Reference

OBSOLETE KIT			REPLACEMENT KIT
PART NO.	DESCRIPTION	APPLICATION	PART NO./ DESCRIPTION
100020	SOFT START	TT300 SIE	Kit no longer supported
100020-1	SOFT START (460V)	All 460V models	100020-19/100020-20 Refer to 1.14 Soft Start Assembly for the proper replacement kit
100020-2	SOFT START (575V)	All 575V models	
100020-3	SOFT START (400V)	All 400V models	
100020-4	SOFT START (380V)	All 380V models	
100020-6	SOFT START, REINFORCED UPGRADE (400V)	All reinforced 400V models	
100020-7	SOFT START, REINFORCED UPGRADE (460V)	All reinforced 460V models	
100021	BACKPLANE ASSY	TT300 SIE	Kit no longer supported
100021-1	BACKPLANE ASSY	All models	100021-2
100035	IGV MOTOR SERVICE	TT300 (R22)	Kit no longer supported for R22 applications All others - 100035-1
100036	SENSOR PRESSURE/TEMPERATURE SUCTION	TT300 (R22)	Kit no longer supported for R22 applications All others - 100036-1
100037	SENSOR PRESSURE/TEMPERATURE DISCHARGE	TT300 (R22)	Kit no longer supported for R22 applications All others - 100037-1
100037-1	PRESSURE/TEMP SENSOR, DISCHARGE	ALL COMPRESSORS	100037-2 SENSOR PRESSURE/TEMPERATURE DISCHARGE
100040-1	DC/DC CONVERTER ASSY 380V	TT300 SIE	Kit no longer supported
100040-3	DC-DC CONVERTER ASSY (575)	All 575V Models	100379 DC-DC
100040-4	DC/DC CONVERTER ASSY (SIE) 480 V	TT300 SIE	Kit no longer supported
100040-5	IGBT ASSY MANIFOLD COOLING TT400 C/W DC/DC CONVERTER	All 400 & 460V models	100379 DC-DC
100040-6	DC-DC CONVERTER ASSY (380V)	All 380V models	100379 DC-DC
100043-1	IGBT 310032 PARALLEL COOLING	TT300 SIE	Kit no longer supported
100043-2	IGBT 320032 SERIAL COOLING	TT300 SIE	Kit no longer supported
100043-3	IGBT MANIFOLD COOLING	TT300 Rev:-N, -P, -C, -D, -E, -F	100521 INVERTER ASSY 613 KIT – INVERTER ASSY CONVERSION 342 TO 613 SERIES
100043-5	IGBT ASSY MANIFOLD COOLING TT400 C/W DC/DC CONVERTER	TT350, TT400, TT500 Rev: -P, -A, -C, -E 460V	100043-11 (DC-DC sold separately)
100043-6	IGBT MANIFOLD COOLING - 575V TT 300	TT300 Rev: -P 575V	Kit no longer supported

OBSOLETE KIT			REPLACEMENT KIT
PART NO.	DESCRIPTION	APPLICATION	PART NO./ DESCRIPTION
100043-7	IGBT MANIFOLD COOLING - TT300 R22 SPLIT COOLING	TT300 (R22)	Kit no longer supported
100043-8	IGBT ASSY - SEMIKRON SKiiP 613 TT400C 575V	TT350, TT400, TT500 Rev: -P, -A, -C, -E 380V, 400V, 460V, 575V	100043-11 INVERTER ASSY 613
100043-12	INVERTER ASSY 342	TT300, TG230 Rev: -N, -P, -C, -D, -E, -F	100521 INVERTER ASSY CONVERSION 342 to 613 SERIES
100043-14	24kHz INVERTER ASSY	TT300 (R134a)/TG230 Rev: -N, -P, -C	100521 INVERTER ASSY CONVERSION 342 to 613 SERIES
100044	BUS BAR ASSY AND CAPACITORS 6800µF (460V)	TT300, TG230 Rev: -N, -P, -C, -D, -E, -F	100044-7 BUS BAR ASSY AND CAPACITORS 6800µF (460V)
100044-1	BUS BAR ASSY AND CAPACITORS 4700µF (575V)	TT300, TG230 Rev: -N, -P, -C, -D, -E, -F, -G	100044-8 BUS BAR ASSY AND CAPACITORS 6800µF (460V)
100044-2	BUS BAR ASSY AND CAPACITORS 9000µF (400V)	TT300, TG230 Rev: -N, -P, -C, -D, -E, -F	100044-6 BUS BAR ASSY AND CAPACITORS 6800µF (460V)
100044-3	BUS BAR ASSY AND CAPACITORS 8500µF (460V)	TT350, TT400, TT500, TT700, TG310, TG390, TG520 Rev: -P, -A, -C, -E, -F	100044-12 BUS BAR ASSY AND CAPACITORS 8500µF (460V)
100044-4	BUS BAR ASSY AND CAPACITORS 11000µF (380/400V)	TT400, TG390 Rev: -P, -C, -E, -F	100044-11 BUS BAR ASSY AND CAPACITORS 11000µF 380/400 VAC
100044-5	BUS BAR ASSY AND CAPACITORS 6800µF (575V)	TT400, TG390 Rev: -P, -C, -E, -F	100044-13 BUS BAR ASSY AND CAPACITORS 6800µF (575V)
100050-1	DRIVE ASSY AND O-RING TT300 (SIE,-N)	TT300 SIE, Rev: -N	Kit no longer supported
100050-2	IGV, DRIVE ASSY AND O-RING, R134a EXTENDED RANGE	TT300 Rev: -P, -C, -D, -E, R134a	100050-16 IGV, DRIVE ASSY AND O-RING TT300/TG230
100050-3	IGV, DRIVE ASSY AND O-RING - TT300 RETROFIT	TT300, TG230 Rev: -P, -C, -D, -E	100050-16 IGV, DRIVE ASSY AND O-RING - TT300/ TG230
100050-5	IGV, DRIVE ASSY AND O-RING - R22 RETROFIT	TT300 R22 Rev: -P	Kit no longer supported

OBSOLETE KIT			REPLACEMENT KIT
PART NO.	DESCRIPTION	APPLICATION	PART NO./ DESCRIPTION
100050-6	IGV, DRIVE ASSY AND O-RING - TT400-P	TT400 Rev: -P	Kit no longer supported
100050-7	IGV, HOUSING ASSY AND O-RING - TT400C	TT400 Rev: -C, -E, R134a	100050-17 IGV, DRIVE ASSY AND O-RING TT400/TG390
100050-8	IGV, HOUSING ASSY AND O-RING -TT500	TT500 Rev: -A, -E, R134a	100050-18 IGV, DRIVE ASSY AND O-RING TT700/TG520
100050-9	IGV, HOUSING ASSY - TT350	TT350 Rev: -A, -E, R134a	100050-15 IGV, DRIVE ASSY AND O-RING TT350/TG310
100050-11	IGV, DRIVE ASSY AND O-RING - TT350 RETROFIT	TT350 Rev: -A, -E, R134a	100050-15 IGV, DRIVE ASSY AND O-RING TT350/ TG310
100050-12	IGV, DRIVE ASSY AND O-RING - TT400 -P RETROFIT	TT400 Rev: -P	Kit no longer supported
100050-13	IGV, DRIVE ASSY AND O-RING - TT400 RETROFIT	TT400 Rev: -C, -E	100050-17 IGV, DRIVE ASSY AND O-RING TT400/ TG390
100050-14	IGV, DRIVE ASSY AND O-RING - TT500 RETROFIT	TT500 Rev: -A, -E	100050-18 IGV, DRIVE ASSY AND O-RING TT700/ TG520
100050-24	IGV, DRIVE ASSY AND O-RING TGS490	TGS490 Rev: -F, -H	100050-25 IGV, DRIVE ASSY AND O-RING TGS490
100052	O-RING, END CAP ASSY	TT300 R22	Kit no longer supported for R22 applications All others - 100352
100052-1	O-RING, SERVICE SIDE SMALL O-RINGS	TT300 R22	Kit no longer supported for R22 applications All others - 100052-2
100052-2	O-RINGS, SERVICE SIDE, SMALL	All models	199K0031 O-RINGS, SERVICE SIDE, SMALL
100053-2	COVER, CAPACITOR ASSY (BLACK PAINTED) TT300	TT300 Rev: -N, -P, -C	100053-3 COVER, CAPACITOR ASSY (BLACK)
100053-5	CAPACITOR COVER ASSY	TT300 Rev: -N, -P, -C	100053-6 COVER, CAPACITOR ASSY (GREEN)

OBSOLETE KIT			REPLACEMENT KIT
PART NO.	DESCRIPTION	APPLICATION	PART NO./ DESCRIPTION
100054-2	COVER, TOP ASSY (BLACK - PAINTED) TT300	TT300 Rev: -N, -P, -C	100054-3 COVER, TOP ASSY (BLACK)
100054-5	COVER, TOP ASSY STANDARD GREEN	TT300 Rev: -N, -P, -C	100054-6 COVER, TOP ASSY GREEN
100055-2	COVER, SERVICE SIDE ASSY (BLACK PAINTED) TT300	TT300 Rev: -N, -P, -C	100055-3 COVER, SERVICE SIDE ASSY (BLACK)
100055-5	COVER, SERVICE SIDE ASSY - (STANDARD GREEN)	TT300 Rev: -N, -P, -C	100055-6 COVER, SERVICE SIDE ASSY - GREEN
100056-2	COVER, MAINS INPUT ASSY (CONDUCTIVE PAINTED BLACK) TT300	TT300 Rev: -N, -P, -C	100056-3 COVER, MAINS INPUT ASSY (BLACK)
100056-5	COVER, MAINS INPUT ASSY (STANDARD GREEN)	TT300 Rev: -N, -P, -C	100056-6 COVER, MAINS INPUT ASSY (GREEN)
100058-2	CABLE HARNESS-ASSY,COMPRESSOR-INTERFACE (SIE)	TT300 SIE	Kit no longer supported
100062	CABLE HARNESS SOFTSTART AC/DC (SIE) TT300	TT300 SIE	Kit no longer supported
100062-3	CABLE HARNESS SOFTSTART AC/DC - TT350/400/700	TT350/400/700 Rev: -P, -A, -C, -E, -F	100381 CABLE HARNESS SOFTSTART AC/DC
100062-4	CABLE HARNESS SOFTSTART AC/DC (TT300/TG230)	TT300/TG230 Rev: -N, -P, -C, -D, -E, -F, -G	100380 CABLE HARNESS - AC/DC - TT300
100076-2	PCB ASSY COMPRESSOR INT CONNECTOR (SIE)	TT300 SIE	Kit no longer supported
100150	COOLING VALVES ASSY TT300/R22	TT300 R22	Kit no longer supported
100150-1	COOLING VALVES ASSY TT400-P	TT400 Rev: -P	100281-4 COOLING VALVES ASSY TT400 380/400/ 460
100150-3	COOLING VALVES ASSY R134a, TT350 &TT500	TT350, TT500 Rev: -A, -E	TT350-100281-5 TT500-100281-3 COOLING VALVES ASSY TT350 400/460V, TT500
100150-4	COOLING VALVES ASSY R134a, TT400C	TT400 Rev: -C, -E, 380V, 400V, 460V	100281-4 COOLING VALVES ASSY TT400 380/400/ 460
100150-5	COOLING VALVES ASS 134a, TT400C 575C	TT400 Rev: -C, -E, 575V	100281-1 COOLING VALVES ASSEMBLY TT400 (575V), TG310
100150-6	KIT, COOLING VALVES ASSY	TTS400 575V TGS310	100281-1 COOLING VALVES ASSY

OBSOLETE KIT			REPLACEMENT KIT
PART NO.	DESCRIPTION	APPLICATION	PART NO./ DESCRIPTION
100150-7	KIT, COOLING VALVES ASSY R134a, TT350, 380V	TT350 Rev: -A, -E, 380V	100281-5 COOLING VALVES ASSY TT350 380V
100150-8	COOLING VALVES ASSY TT300	TTS300 TGS230	100281-2 COOLING VALVES ASSY TT300
100150-9	COOLING VALVES ASSY	TTS500 TTS700 TGS520	100281-3 COOLING VALVES ASSY
100150-10	COOLING VALVES ASSY TT400	TTS400 380V, 400V & 460V TGS390	100281-4 COOLING VALVES ASSY TT400
100150-11	COOLING VALVES ASSY	TTS350 TGS490 TTH375 TGH285	100281-5 COOLING VALVES ASSY
100150-12	COOLING VALVES ASSY	TTH375 TGH285	100281-5 COOLING VALVES ASSY
100151	SUCTION FLANGE (STEEL)	TT300, TT350, TT400 Ref: R134a	100151-1 SUCTION FLANGE (STEEL)
100153	DISCHARGE FLANGE (STEEL)	TT350, TT400, TG310, TG390	100153-1 DISCHARGE FLANGE (STEEL)
100155	O-RING SUCTION PORT	TT300 R22	Kit no longer supported for R22 applications All others - 100051-1
100169	ADAPTER SCREEN FITTING ASSY	TT300, TT350, TT400, TT500 Rev: -E	100169-1 COMPRESSOR COOLING ADAPTER WITH STRAINER
100186	STRAINER, COOLING LINE ADAPTER, SCREEN FITTING	TT300, TT350, TT400, TT500 Rev: -E	100186-1 STRAINER
100196-1	CAVITY TEMP SENSOR TT300,TT350 & TT400	TT300, TT350, TT400 Rev: -E	100196-3 CAVITY TEMP SENSOR
100215	COOLING FITTING AND STRAINER	TTS300 Rev: -N, -P, -C, -D	Kit no longer supported Parker fitting P/N 48F-6-4 or equivalent. Refer to the specifications below: <ul style="list-style-type: none"> • Brass 45° flare fitting • Connection 1 tube o.d. (inch): 3/8 • Connection 2 thread size (inch): 1/4 • Style: flare to NPT

OBSOLETE KIT			REPLACEMENT KIT
PART NO.	DESCRIPTION	APPLICATION	PART NO./ DESCRIPTION
100223-4	IGV HOUSING	TT300/TT350/ TT400/TG230/TG390 Retrofit compressors	100223 IGV HOUSING
100224	IGV HOUSING, TT300 (SIE, -N, R22)	TT300 SIE Rev: -N	Kit no longer supported
100224-4	IGV HOUSING, TT300 (SIE, -N, R22)	TT300 SIE Rev: -N	Kit no longer supported
100226	IGV THROAT, TT300 (SIE, -N, -P-6%)	SIE Rev: -N	Kit no longer supported
100229-4	IGV HOUSING TT500/TT700/TG520	TT500/TT700/TG520 Retrofit compressors	100229 IGV HOUSING TT500/TT700/ TG520
100230	IGV THROAT, TT400P	TT400 Rev: -P	Kit no longer supported
100233	PLUNGER ASSY, SOLENOID	Use with TT300 R22/ TT400 Rev: -P	Kit no longer supported for R22 applications All others - 100280
100234	SOFT START COOLING FAN ASSY	All models	100373 COOLING FAN AND ADAPTOR ASSY
100235	PLUNGER ASSY, SOLENOID	All models	100280 PLUNGER ASSY, SOLENOID
100237	ORIFICE BODY, COOLING 1.5MM	TT400 Rev: -P	100240 ORIFICE BODY, COOLING 1.6MM
100241	O-RING SOLENOID ORIFICE	TT300 R22	Kit no longer supported
100242	O-RING, SOLENOID ORIFICE	All models	199K0030 O-RING, SOLENOID ORIFICE
100250	IGV THROAT, TGS490	TGS490 Rev: -F, -H	100261 IGV THROAT, TGS490
100272	COMPRESSOR CONTROLLER (SIE)	TT300 SIE	Kit no longer supported
100281-5	COOLING VALVE ASSY	TTS350, TTS450, TGS285, TGS380, TGS490, TTH375	199K0029 COOLING VALVE ASSY
100293	HERMETIC FEEDTHROUGH FRONT BEARING - 4 PIN	TT300 R22	Kit no longer supported for R22 applications All others - 100293-1
100294	HERMETIC FEEDTHROUGH REAR BEARING - 6 PIN	TT300 R22	Kit no longer supported for R22 applications All others - 100294-1

OBSOLETE KIT			REPLACEMENT KIT
PART NO.	DESCRIPTION	APPLICATION	PART NO./ DESCRIPTION
100295	HERMETIC FEEDTHROUGH BEARING - 9 PIN	TT300 R22	Kit no longer supported for R22 applications All others - 100295-1
100309	HEATSINK, COOLING MANIFOLD SCR ASSY	TT300 Rev: -N, -P, -A, -C, -D, -E, R134a	100309-11 HEATSINK COOLING MANIFOLD SCR ASSY
100309-1	HEATSINK, COOLING MANIFOLD SCR ASSY (TT400)	TT350, TT400, TT500 Rev: -P, -A, -C, -E	100309-13 HEATSINK COOLING MANIFOLD SCR ASSY
100309-2	HEATSINK, COOLING MANIFOLD SCR ASSY	TT300 R22	Kit no longer supported
100309-3	DIODE HEATSINK, SERIAL COOLING (SIE)	TT300 SIE	Kit no longer supported
100309-4	DIODE HEATSINK, PARALLEL COOLING (SIE)	TT300 SIE	Kit no longer supported
100309-5	HEATSINK COOLING MANIFOLD SCR ASSY	TTS350, TTS400, TTS500, TTS700, TGS310, TGS390, TGS490, TGS520 Rev: -P, -A, -C, -E, -F	100309-13 HEATSINK, COOLING MANIFOLD SCR ASSY (TT350) NO SENSOR
100309-6	HEATSINK COOLING MANIFOLD SCR ASSY	TTS300/TGS230 Rev: -N, -P, -C, -D, -E, -F, -G	100309-11 HEATSINK, COOLING MANIFOLD SCR ASSY
100309-9	SCR COOLING MANIFOLD	TTS350, TTS400, TTS700, TGS310, TGS390, TGS490, TGS520 Rev: -H	199K0024 SCR COOLING MANIFOLD
100309-15	SCR COOLING MANIFOLD	TGS380/TTS450	199K0024 SCR COOLING MANIFOLD
100310	O-RING, IGBT ASSY	TT300 R22	Kit no longer supported for R22 applications All others - 100310-2
100312	HERMETIC FEEDTHROUGH HIGH POWER NEOPRENE	TT300 R22	Kit no longer supported for R22 applications All others - 100383
100312-1	HERMETIC FEEDTHROUGH HIGH POWER EPDM	All models	Kit no longer supported for R22 applications All others - 100383
100314	COVER PLATE ASSY	TT300 R22	Kit no longer supported for R22 applications All others - 100314-2
100315	O-RING, COVER PLATE ASSY	TT300 R22	Kit no longer supported for R22 applications All others - 100315-1
100321	HERMETIC FEEDTHROUGH IGV 4 PIN	TT300 R22	Kit no longer supported R22 All others - 100321-1

OBSOLETE KIT			REPLACEMENT KIT
PART NO.	DESCRIPTION	APPLICATION	PART NO./ DESCRIPTION
100322	CABLE HARNESS COMPRESSOR CONTROLLER	All models	100322-5 CABLE HARNESS COMPRESSOR CONTROLLER
100322-2	CABLE HARNESS COMPRESSOR CONTROLLER (SIE)	TT300 SIE	Kit no longer supported
100322-3	CABLE HARNESS COMPRESSOR CONTROLLER (SIE)	TT300 SIE	Kit no longer supported
100323-1	CABLE HARNESS COMPRESSOR DC SUPPLY (SIE)	TT300 SIE	Kit no longer supported
100324	END CAP ASSY	TT300 R22	Kit no longer supported for R22 applications All others - 100324-2
100326-1	CABLE HARNESS DC BUS TEST LEAD (SIE)	TT300 SIE	Kit no longer supported
100327	O-RING COOLING PORTS, SUCTION, DISCHARGE, ECONOMIZER, MOTOR COOLING	TT300 R22	Kit no longer supported for R22 applications All others - 100329
100373	COOLING FAN AND ADAPTOR ASSY	All models	100373-1 COOLING FAN AND ADAPTOR ASSY
100374	R513A REFRIGERANT LABEL	TTS300/TTS350/TTS400/TTS500/TTS700/ TTH375 Rev: -F, -G, -H	199K0002 & 199K0003 R134a-R513A LABELS/R1234ze-R515B LABELS
100375	HARMONIC RESISTOR PLUG	All models	Kit no longer supported
100381-1	HIGH-POWER FEEDTHROUGH	All models	Kit no longer supported for R22 applications All others - 100383
100402	SUCTION FLANGE KIT (BRASS)	TT300, TT350, TT400 R134a	100402-1 SUCTION FLANGE (BRASS)
100414	ECONOMIZER VALVE KIT 7/8"	TT300 R134a	Kit no longer supported
100417-1	INVERTER SNUBBER CAPACITOR, 0.47µF, 1250VDC	TTS350/TTS400/TTS450/TTS500/TTS700/ TGS310/TGS380/TGS390/TGS490/ TGS520/TTH375/TGH285	100417-2 INVERTER SNUBBER CAPACITOR, 0.47µF, 1250VDC
100417-2	SNUBBER CAPACITOR, 0.47µF, 1000VDC	TTS300/TGS230 Rev: -H	199K0078 SNUBBER CAPACITOR, 0.56µF, 1000VDC
100419	PLUNGER ASSEMBLY, NON-RETURN VALVE	TT300	Kit no longer supported
100420	FUSE 4 AMP (SIE) (TT300)	TT300 SIE	Kit no longer supported

OBSOLETE KIT			REPLACEMENT KIT
PART NO.	DESCRIPTION	APPLICATION	PART NO./ DESCRIPTION
100450	ECONOMIZER FLANGE KIT 1 3/8" (BRASS)	All except TT300 and TG230	100450-1 ECONOMIZER FLANGE 1 3/8" (BRASS)
100455	SUCTION FLANGE 3 5/8" (BRASS)	TT500, TT700, TG520	100378 SUCTION BRASS FLANGE FOR 3- 5/8" COPPER PIPE TT500 (EPDM O- ring)
100472	SUCTION STRAINER KIT	All models	Kit no longer supported
100514	CONVERSION-SIE TO THE CURRENT ELECTRONICS (400V)	All 400V SIE models	Kit no longer supported
100515	CONVERSION-SIE TO THE CURRENT ELECTRONICS (400V)	All 400V SIE models	Kit no longer supported
100516	CONVERSION-SIE TO THE CURRENT ELECTRONICS (460V)	All 460V SIE models	Kit no longer supported
100517	CONVERSION-SIE TO THE CURRENT ELECTRONICS (460V)	All 460V SIE models	Kit no longer supported
100555	O-RING, SUCTION PORT	All models	100329 O-RINGS, PORT CONNECTIONS
100580	PORTABLE TRAINING SIMULATOR	All models	N/A - Contact Applications & Product Support team to request a Simulator
100703-1	INTERSTAGE PIPE	TTH375/TGH285 Rev: -F, -H	Order Kit 100703-3 and 100706-3
100706-1	SECOND STAGE HOUSING	TTH375/TGH285 Rev: -F, -H	Order Kit 100703-3 and 100706-3
901453	LINE REACTOR 140A - 10%	TTS300/TGS230	901832 LINE REACTOR 240A - 5%
901666	EMI FILTER (CE) 185A	All models	901866 EMI/EMC FILTER (CE) 322A
901974	LINE REACTOR 140A - 5%	TTS300/TGS230	901832 LINE REACTOR 240A - 5%
901975	LINE REACTOR 180A - 5%	All models	901832 LINE REACTOR 240A - 5%

Quick access to Danfoss TurboCor® compressor troubleshooting.

The new version of the **Danfoss TurboTool® 2.0** app for all your full service Danfoss TurboCor® compressor needs.

24/7

Access to Danfoss TurboCor® compressor troubleshooting on site



The TurboTool® app makes it easy for technicians to troubleshoot issues on Danfoss TurboCor® compressors.

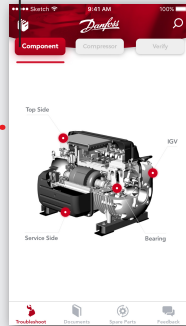

The user can select from a list of symptoms in the app that match the problems exhibited by the compressor being serviced. The app will then list potential causes, solutions to the problem, and service literature for reference for further information.

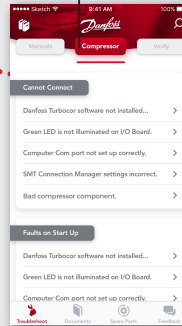

The app provides the correct operating parameters for key components; no need to keep reference documents on hand.

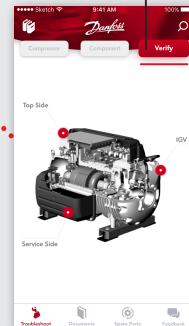

Troubleshoot

You no longer need to keep hundreds of pages of parts catalogs and training manuals. With the app, all of this information is at your fingertips on your smart device.

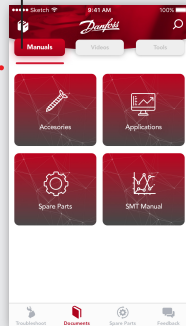

With the app, you can access videos made by Danfoss TurboCor® that demonstrate how to remove, install, and rebuild key components on Danfoss TurboCor® compressors.

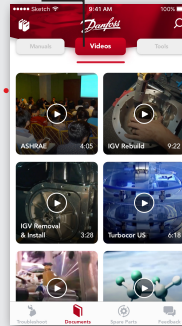

Documents & Video

Spare Parts

Download the 2.0 app today!



Scan to download app

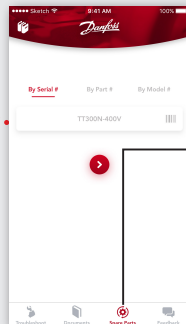

TurboTool® helps you to quickly identify the required spare parts. A quick scan of the compressor serial # using your smartphone camera or by entering the part # or model #, and the app will display potential spare parts kits.



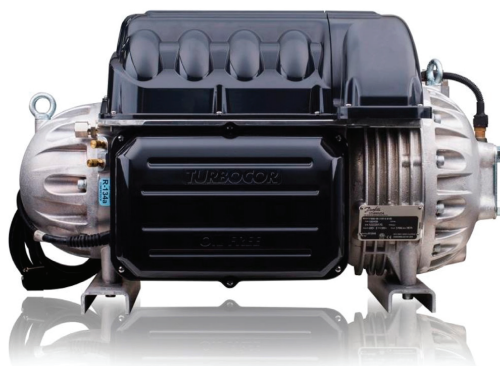

Boost your Turbocor® knowledge

The Danfoss Turbocor® Training Program - Service, Maintenance, and Troubleshooting

- Online and face-to-face training modules
- Discover the advantages of oil-free technology
- Go hands-on with a Turbocor compressor
- Master the Turbocor monitoring software
- Interact directly with Danfoss experts

Highly qualified and field-experienced instructors of the **Danfoss Turbocor® Learning Center** will provide you with a high level of training.

Attendees will be trained in three key areas of the Turbocor® program that includes:

- Practical classroom courses
- Hands-on compressor demonstrations
- Service Monitoring Tools software applications

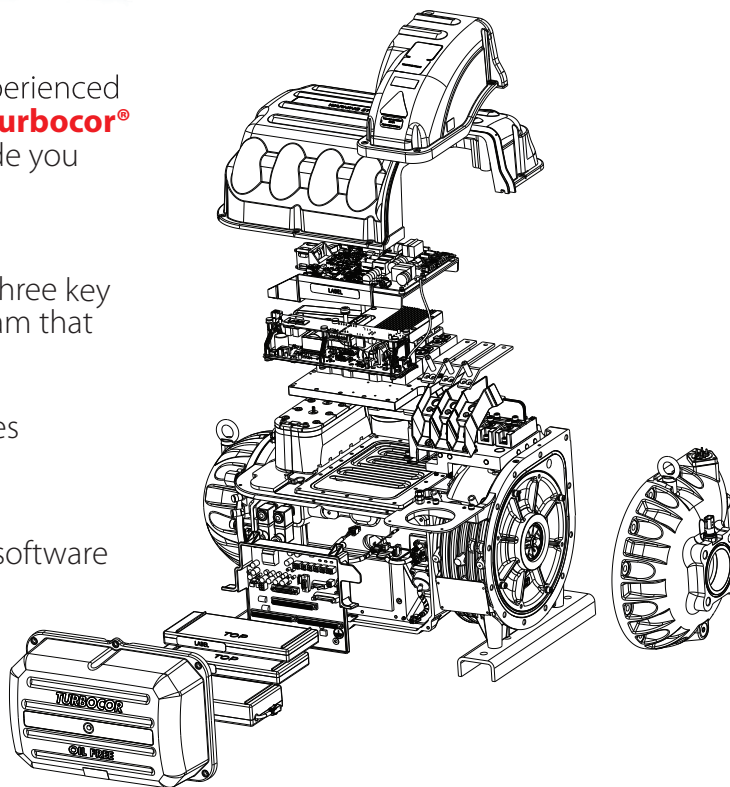

Join us for the next **Turbocor® Training** class. Scan the code to see our schedule and **register today!**

www.turbocor.danfoss.com | **TURBOCOR®**



Explore our solutions at danfoss.com.

Additional product literature is available at turbocoroem.com.

Danfoss Turbocor® Compressors
1769 E. Paul Dirac Drive Tallahassee, FL 32310
USA
+1 850 504-4800

Danfoss Turbocor® Compressors
22nd Floor, Block C,
900 Yi Shan Road, Shang Hai,
China Shanghai, China 200233
+86 (0) 21 6151-3000

Danfoss Turbocor® Compressors
Nordborgvej 81, DK-6430 Nordborg
+45 7488 2222

Danfoss can accept no responsibility for possible errors in catalogues, brochures and other printed material. Danfoss reserves the right to alter its products without notice. This also applies to products already on order provided that such alterations can be made without subsequent changes being necessary in specifications already agreed. All trademarks in this material are property of the respective companies. Danfoss and the Danfoss logotype are trademarks of Danfoss A/S. All rights reserved.
